

J. W. OSBORNE.  
TYPE WRITING MACHINE.

No. 383,482.

Patented May 29, 1888.

*Fig. 1.*

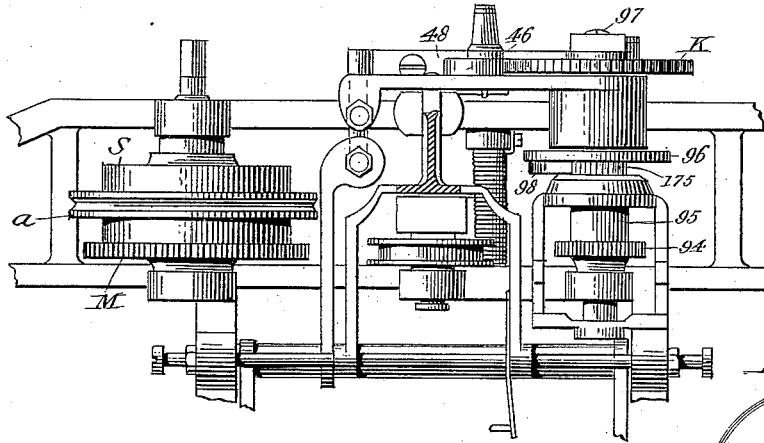

*Fig. 11.*

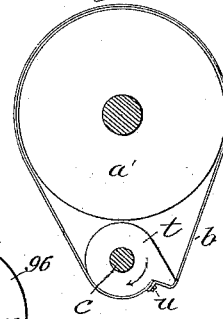

*Fig. 2.*

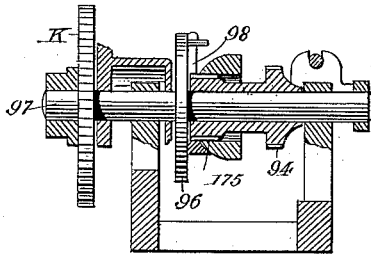

*Fig. 3.*

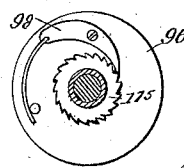

*Fig. 12.*

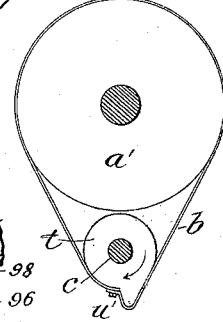

*Fig. 4. N*

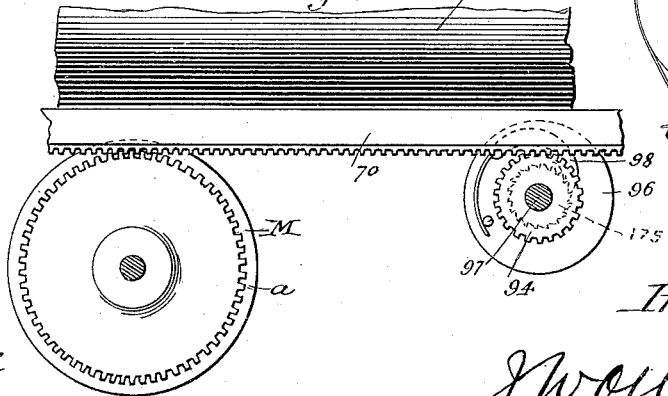

Witnesses:  
*J. Clark*  
*C. White*

*Inventor:*

*J. W. Osborne*

(No Model.)

8 Sheets—Sheet 2.

J. W. OSBORNE.  
TYPE WRITING MACHINE.

No. 383,482.

Patented May 29, 1888.

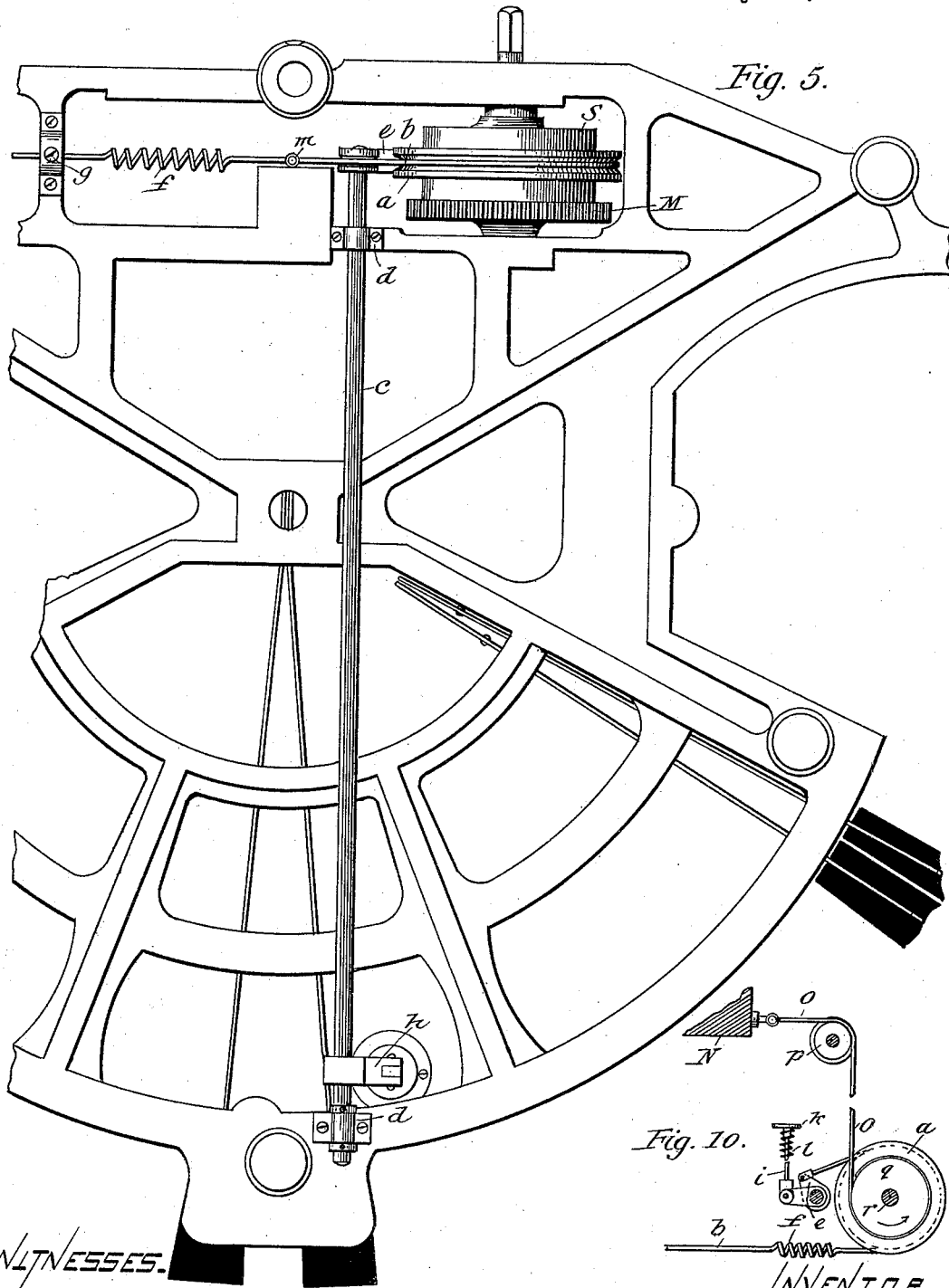

Fig. 5.

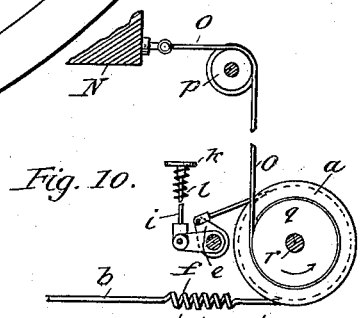

Fig. 10.

WITNESSES.  
 Lewis A. Clark  
*[Signature]*

INVENTOR.  
*J. W. Osborne.*

(No Model.)

3 Sheets—Sheet 3.

J. W. OSBORNE.  
TYPE WRITING MACHINE.

No. 383,482.

Patented May 29, 1888.

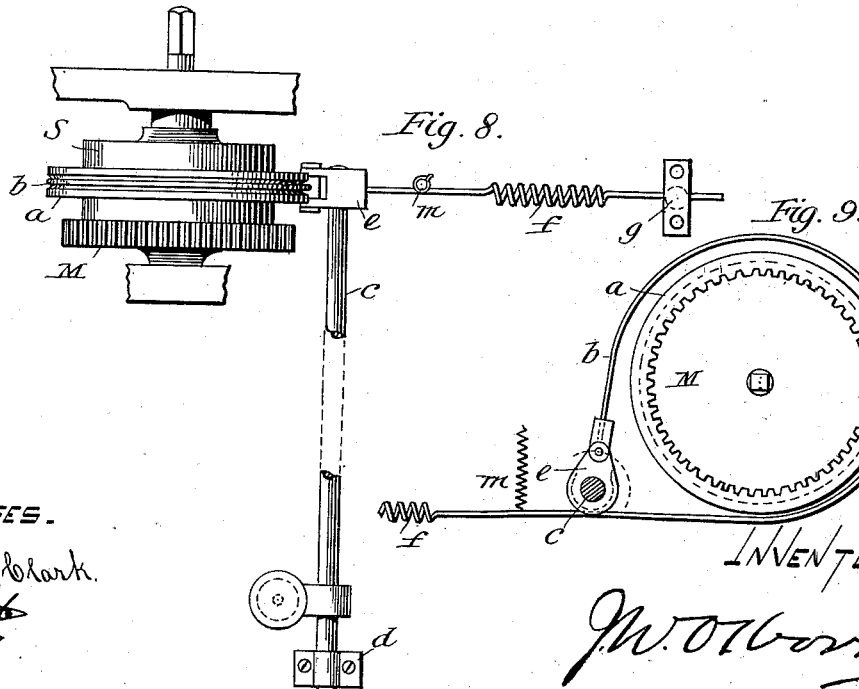
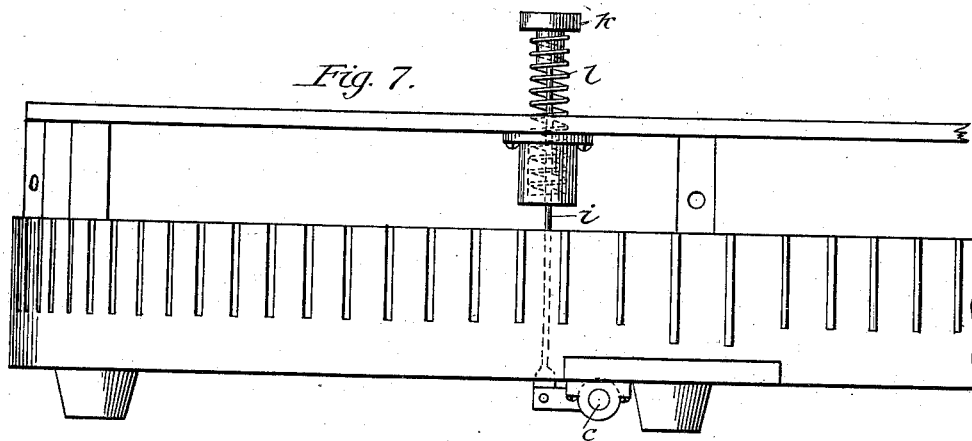
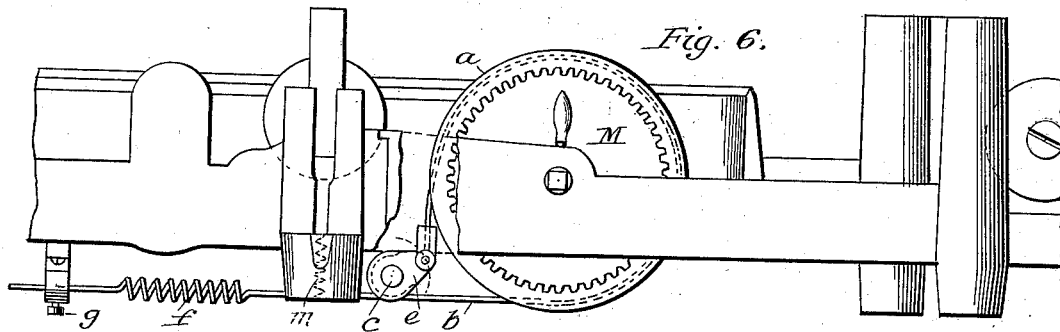

WITNESSES.

Louis A. Clark.

*[Handwritten signature]*

INVENTOR:

*J. W. Osborne*

# UNITED STATES PATENT OFFICE.

JOHN W. OSBORNE, OF WASHINGTON, DISTRICT OF COLUMBIA.

## TYPE-WRITING MACHINE.

SPECIFICATION forming part of Letters Patent No. 383,482, dated May 29, 1888.

Application filed March 7, 1887. Serial No. 239,910. (No model.)

*To all whom it may concern:*

Be it known that I, JOHN W. OSBORNE, a subject of the Queen of Great Britain, residing at Washington, in the District of Columbia, have invented certain new and useful Improvements in Type-Writing Machines; and I do declare the following to be a full, clear, and exact description of the invention, such as will enable others skilled in the art to which it appertains to make and use the same, reference being had to the accompanying drawings, and to the letters and figures of reference marked thereon, which form a part of this specification.

This invention is related to the devices, common to most type-writers, which determine and control the intermittent forward movement of the paper carrier or carriage, and, in connection therewith, the successive imprinting upon the paper of the characters used in writing. Its object is to accomplish the retrograde movement of the carriage one step at a time in a more convenient and better way than is practiced at present, and to do this by means of a distinct and separate attachment which has connection with the mechanism of the type-writer only while in operative activity with the same, whereby advantages are secured, which will be hereinafter more fully set forth.

In the drawings which form a part of this specification my invention is illustrated chiefly as an attachment added to the mechanism, now well known and understood, which has been found serviceable in the Hammond type-writer; but it is also applicable to other instruments of the kind, as will be subsequently explained.

In the drawings, Figure 1 shows in plan the driving and escapement mechanism of a Hammond type-writer. Figs. 2 and 3 are detail views of parts of the same. Fig. 4 is an elevation from the front showing the actuating connection between the driving mechanism and the escapement. Fig. 5 is an inverted plan of part of the bed plate or frame of the machine with my attachment in place. Fig. 6 is a back elevation, and Fig. 7 a front elevation, of part of the same. Fig. 8 is a view of the attachment as seen from above. Fig. 9 is a side elevation of part of the same, and Fig. 10 is a modified form of my invention. Figs.

11 and 12 are modified applications of the principle involved.

In the following description reference will be frequently made to the devices employed in the Hammond type-writer as at present constructed, the same being substantially an embodiment of the machine described and claimed in the Letters Patent issued to J. B. Hammond December 18, 1883, and numbered 290,419. In the figures those parts which are in use (called in the description by their trade names) are indicated by capital letters or numbers, while those that are new and are my invention are marked with small letters exclusively; and to avoid misconception it may also be stated that the key-board at which the operator sits is spoken of as the "front" of the machine, and the "right," "left," and "back" are spoken of as with reference to his position.

In a type-writer such as is here considered the feed-motion of the carriage is from right to left, to allow of the gradual progress of the writing on the paper from left to right. This progressive movement is necessarily intermittent, a distance equal in length to the width of a letter being accomplished after each letter is made, or after the space-key has been depressed. The force which accomplishes this step-by-step motion is stored in the clock-spring contained in the "casing" or barrel S, and the mechanism which controls the progressive movement of the carriage is an "escapement-wheel," K, with its pawls 46 and 48. The reciprocal connection between these important parts of the mechanism is effected by means of the "rack-bar" 70, which is part of the carriage N, being bolted to the same. This rack meshes into the large gear M on the barrel S, and also into a pinion, 94, on the "escapement-shaft" 97. When the carriage is forced back toward the right, so that the operator can begin a line of writing, he winds up the spring in the barrel by that act, and when at any time he lets go the carriage it is hindered from returning forthwith to the left, because in doing so the escapement-wheel K must revolve, which it cannot do, being locked by pawl 46.

In operating the keys of the machine and the space-key the pawls 46 and 48 are alter-

nately brought into play, and the result is the intermittent rotation of the escapement-wheel K in the well-known way, the further discussion of which is not pertinent at present; but in pushing the carriage to the right it is important that the wheel K be not forced to revolve thereby, and therefore the mechanical connection with the escapement mechanism is accomplished through the "free sleeve" 95 on the escapement-shaft 97. This sleeve has at one end the pinion 94, (shown in plan in Fig. 1 and in section in Fig. 2,) with which the rack 70 engages, and at the other end the ratchet-wheel 175. On the shaft 97 the circular "disk" 96 is firmly fixed, and to this the "spring-pawl" 98 is pivoted. (Shown in elevation in Fig. 2.) Said pawl co-operates with the ratchet 175 in such a way as to cause the escapement-shaft to rotate with the sleeve, when the actuating-spring in S pulls the carriage to the left, whereas the sleeve only is driven, and not the shaft, when the carriage is pushed by hand to the right, the pawl 98 then riding freely over the ratchet 175. From what has been said it will be seen that to return the carriage at any time to the position it has just left—that is, to put it back one space—can be easily accomplished by pressing with the finger of the left hand against the same and urging it to the right till the pawl 98 is heard to fall into the next tooth, or till the operator sees that a space has been retraced. In the daily use of a type-writer this retrograde movement of one space at a time is frequently desirable for rewriting erased letters, the insertion of forgotten punctuation-marks, and for other purposes.

My invention consists in the construction of a "back motion" without complexity, and designed as an attachment applicable to existing machines without interference with their plan or the functions of their several parts, thereby giving such instruments a "backward carriage-feed" somewhat analogous to the forward feed furnished by the space-key. Generally stated, it consists in laying hold mechanically of the barrel S, in whatever position it may be at the time, and rotating it backward—that is, in the direction calculated to wind up the spring contained therein—until the spring-pawl 98 falls into the next tooth of the ratchet 175, which then holds the carriage in its new position, and my arrangement is such that a complete operation of the attached mechanism accomplishes this change, moving the carriage one step only.

In Figs. 5, 6, 7, and 8 different views of the apparatus adapted for a Hammond type-writer as at present constructed are shown, the apparatus not directly involved in my invention being for the most part removed and only parts of the frame represented. The barrel S, having the driving-spring within it, has firmly shrunk or otherwise fastened upon its outside the ring *a*, grooved like a pulley for a round belt. In this groove a wire, *b*, bent in part to a true circular curve, is placed. This wire

forms a friction-strap, and is supported as follows: The small shaft *c*, running the whole length of the frame, has bearings at *d*. One end of it carries the short arm *e*, firmly attached, the outer end of which lever is hinged to one extremity of the wire *b*. The other end of the wire, after it has passed round the pulley *a*, is carried out straight for some distance, and then formed into a short stiff spiral spring, *f*, beyond which it is made fast to the frame by a set-screw at *g*. The wire *b*, when properly adjusted, lies in or close to the groove in *a*, but not in contact with it. Its relation to the pulley in this respect is shown slightly exaggerated in Fig. 9. Under these circumstances it is obvious that, having no connection with the barrel S, the friction-strap *b* in its normal condition is out of gear with the barrel and offers no impediment to the motion of the same in either direction, and has therefore no influence upon the movements made by the keys or imparted by hand directly to the carriage-rack meshing into the gear M and the pinion 94. If, now, the shaft *c* be rotated so as to depress the short lever *e*, which is fast upon its end, and bring it into the position shown in Fig. 6, the wire *b* will be thrown into gear—that is, it will come into close contact with the groove in the pulley *a*, adapting itself to the slightly smaller curve of the same, so as to grasp it firmly, and if the rotation of the shaft be carried still farther in the same direction the spring *f* will yield, and the barrel S will rotate in the direction in which the friction-strap is pulled. This direction is backward, and when the carriage has by this procedure been carried so far that the rotation of the sleeve 95 has caused the spring-pawl 98 to fall into the next tooth, which represents a space in the writing, it will not return, and the desired position of the carriage is gained. If the shaft *c* be now returned to its original position, the elevation of the lever *e* and the natural elasticity of the wire *b* will cause the latter to spring away from the pulley *a*, setting it thereby perfectly free, as before, the spring *f* also contracting so as to be ready for the next elongation.

The partial rotations of the shaft *c*, whereby the strap is thrown into and out of gear, are effected by simple means, which may assume various forms, two of which are illustrated in this case. Whatever the construction of these means may be, however, they must operate to tighten the friction-strap upon the pulley *a* and to rotate the latter in opposition to the carriage-feed, and I shall hereinafter refer to these means by the generic and sufficiently-descriptive term "strap-tightener." Any suitable system of levers or other mechanical powers connected with the friction-strap and extended within convenient reach of the hand of the operator may obviously be used as a strap-tightener. I have shown the following in addition to the shaft *c* and lever *e*. At the end nearest the operator a second short lever, *h*, is firmly attached to the shaft, and hinged to it

is an upright rod, *i*, which passes upward through the wood-work which covers the greater part of the machine. (See Fig. 7.)

This rod terminates above in a flat key or button, *k*, which admits of some adjustment in height upon the rod by screwing it up or down. This button is pressed upward by means of a spiral spring, *l*, the effect of which is to sustain the lever *h*, and to keep the short arm *e* in its elevated position, as in Fig. 9, and therefore to maintain and when disturbed to restore the disconnected or normal condition of the whole arrangement, all of which could be equally well accomplished by a torsional spring on the shaft *c*; but when the finger of the operator depresses the key *k*, thereby compressing the spring *l* and rotating the shaft *c*, the grasping of the pulley *a* and its rotation backward takes place as a necessary consequence, and if properly adjusted the pawl 98 will have fallen in just before the button *k* strikes the wooden covering of the machine beneath it, said button acting as a stop to determine the throw of the system of levers, which brings about the rotation in the rotary element of the carriage feeding mechanism, which rotary element in this instance is the spring-barrel *S*. It is, however, clear that the friction-strap may be applied to any other suitable rotary element of the carriage-feed mechanism.

To steady the wire between its attachment to the frame at *g* and the place where it first meets the pulley at a tangent, I construct a little groove in the boss of the arm *e*, (best seen in Fig. 5,) and hold the wire *b* in it by means of the feeble spring *m*, which can yield in either direction. As this mode of seizing the barrel *S* depends on friction, it is desirable, if a round wire is used, that the angular groove in the pulley should be rather acute, but not so much so that the wire is in danger of sticking in the groove and so interfering with the perfect independence of the mechanism after the button *k* has been released and the strap thrown out of gear. It is plain that in place of the round wire *b* a flat friction-strap may be used with perfect success, in which case the pulley *b* might be dispensed with and the thin ribbon of metal allowed to lie upon the face of the barrel itself.

When, for any reason, it should be found desirable to remove the shaft *c* from the position shown, a pulley on a shaft of its own and connected by gearing or by other means with the teeth of the wheel *M*, or with those of the rack 70 or pinion 94, may be placed anywhere under the machine, and a friction-strap, as *b*, placed about the rotary element thus introduced, precisely as has been above described. (See Fig. 10.) When, too, it is wished to apply my invention in cases where the motive spring is so placed that its casing is not readily grasped or geared to, or is altogether absent, I apply a modification such as that shown in Fig. 10, which is diagrammatic in character. Here the carriage to be moved is repre-

sented at *N*. This may be connected by a flexible strap, *o*, and if for any reason the direction of the pull has to be changed, the same may be passed over the pulley *p* to the drum *q*, which is rotated in the direction of the arrow by a feeble spring inside, one which is only strong enough to keep the strap or cord *o* stretched pending the movements of the carriage. If there be now connected with the drum or with the shaft *r* a pulley, *a*, as before, with provision for grasping it by the wire *b*, it can be rotated at any time, so as to pull the carriage back an adjustable distance, as already explained, said distance being long enough to allow of the engagement of the pawl that checks the forward motion of the carriage in the usual way, step by step, or as that which falls into engagement when the carriage is directly put back one step by the finger of the operator, as may be done in all type-writers that have a carriage-feed mechanism, each space-tooth on the ratchet, as *K* or 175, representing such a distance, and while one space backward at a time is clearly of the greatest practical utility, still my invention is applicable if two or more spaces are required for each depression of the key *k*, and although in my preferred method of grasping and rotating an integral part of the carriage-feed mechanism I have shown and described the friction-strap *b* as made fast to a fixed abutment at *g*, yet this is not essential; nor is the extensible quality of the strap as provided for by the interposition of the spring *f* an indispensable condition of its use, either before or after it is thrown into gear with the carriage-feed mechanism. Figs. 11 and 12 illustrate diagrammatically in two positions an arrangement of the friction-strap and a strap-tightener in which both ends of the strap are movable, and a spring giving it extensibility is dispensed with. In this case *a'* is any rotating part of the carriage-feed mechanism, such as the barrel containing the driving-spring, the sleeve 95, or an independent pulley connected with such parts or with the carriage rack itself, as before explained. On the shaft *c* a cam-shaped pulley, *t*, is fixed, which can be rotated reciprocally through a sufficient arc, as in the case of the short lever *e*. Both ends of the friction-strap *b* are brought together and held by a clamping-screw, *u*. In Fig. 11 the strap *b* is shown in its normal position—that is, off the pulley *a'* and out of gear with the whole carriage-feed mechanism; but when the cam-shaped pulley *t* is turned by the operator in the direction of the arrow, so as to bring its projection into the position shown in Fig. 12, the strap *b* will then be drawn tight on the pulley *a'*, as shown, and if the rotation be still continued the pulley *a'* will rotate at the same surface speed and to the same peripheral extent as the circular part of *t*, which need only be continued till a pawl, as 98, falls into the next space-tooth of the ratchet, which, as before explained, is a very short distance. The reason why the belt in this case leaves its normal loose posi-

tion about the pulley  $a'$ , and having first grasped the same then rotates it, is in the fact that until the position in Fig. 12 is reached one end of the strap is drawn off  $a'$  much faster than the other is fed to it, because of the difference in radius of the points of its junction with  $t$ ; but when the effective part of the rotation is proceeded with, the round part of the cam-shaped pulley being then only engaged, the pulley  $a'$  is driven, as by any belt which maintains its grasp thereon unchanged. Of course in practice, if the friction-strap is metallic, one end of it may be hinged properly to the projection on  $t$  to prevent its injury from excessive wear and tear.

Having thus described my invention and the practical working of the same, I wish it to be understood that I do not confine myself to the special devices shown and described, as I am well aware that others may be substituted for them without departing from my invention.

What I claim is—

1. In a type-writer, the combination of the carriage-feed mechanism and a friction-strap normally out of gear with the same with a strap-tightener adapted to the friction-strap for throwing it into gear with the carriage-feed mechanism and for actuating the latter in opposition to the direction of the feed of the carriage, substantially as described.

2. In a type-writer, the combination of a rotary element of the carriage-feed mechanism with a friction-strap loosely surrounding the same, and a strap-tightener adapted to the strap for tightening it upon the rotary element and for rotating the latter in opposition to the direction of the carriage-feed, substantially as and for the purpose described.

3. In a type-writer, the combination of the carriage-feed mechanism and of an extensible friction-strap normally out of gear with said mechanism with a strap-tightener adapted to the extensible friction-strap for throwing it into gear with the carriage-feed mechanism, and for actuating the latter in opposition to the direction of the carriage-feed, substantially as and for the purpose described.

4. In a type-writer, the combination of a rotary element of the carriage-feed mechanism with an extensible friction-strap loosely surrounding the same, and a strap-tightener

adapted to the strap for tightening it upon the rotary element and for rotating the latter in opposition to the direction of the carriage-feed, substantially as described.

5. In a type-writer, the combination of the carriage-feed mechanism thereof and a friction-strap normally out of gear with said mechanism with lever-connections extended within convenient reach of the operator for throwing the strap into gear with the feed mechanism and for actuating the latter in opposition to the direction of the carriage-feed, substantially as described.

6. In a type-writer, the combination of the carriage-feed mechanism thereof and a friction-strap normally out of gear with said mechanism with lever-connections extended within convenient reach of the operator for throwing the strap into gear with said mechanism and for actuating the latter in opposition to the direction of the feed, and a stop for determining the throw of the lever, and thereby the backward feed of the carriage, substantially as described.

7. In a type-writer, the combination of the carriage-feed mechanism thereof and a friction-strap normally out of gear with said mechanism with lever-connections extended within convenient reach of the operator for throwing the strap into gear with said mechanism and for actuating the latter in opposition to the direction of the feed, with a stop for determining the throw of the lever, and a spring to restore said lever and strap to their normal position, substantially as described.

8. In a type-writer, the combination of a rotary element of the carriage-feed mechanism and the pawl and ratchet for holding the carriage against the actuating-spring with a friction-strap adapted to grasp the rotary element of the carriage-feed mechanism, and lever-connections, substantially as described, for drawing one end of said friction-strap (acting as a belt) against the actuating-spring through an interval representing one space-tooth of said ratchet, substantially as described.

In testimony whereof I affix my signature in presence of two witnesses.

J. W. OSBORNE.

Witnesses:

WM. C. TURNER,  
E. T. WHITE.