

(No Model.)

H. A. HOUSE & H. A. HOUSE, Jr.

RELIEF VALVE FOR DOOR CHECKS.

No. 384,907.

Patented June 19, 1888.

Fig 1

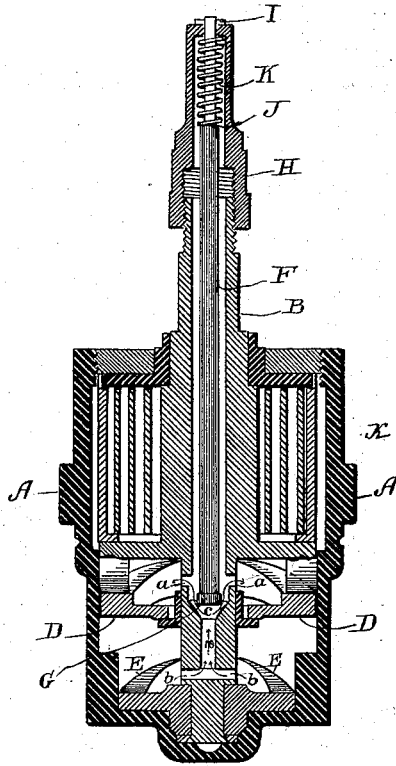
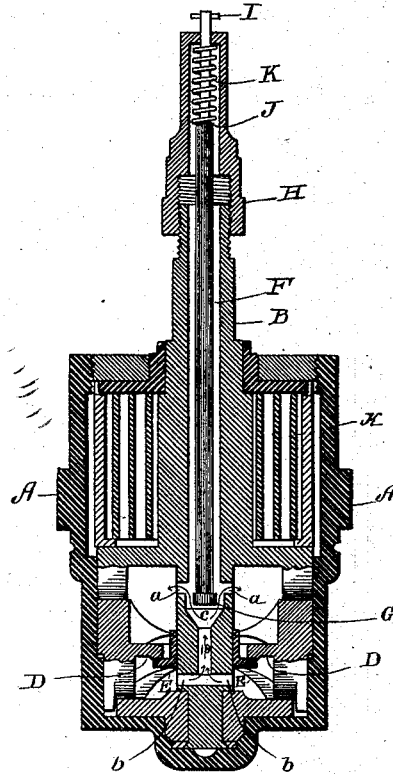

Fig 2



Witnesses.
S. Williamson.
Saml. M. Rowell.

Inventors.
Henry A. House.
Henry A. House Jr.
By *Smith Hubbard* *Atlys.*

UNITED STATES PATENT OFFICE.

HENRY A. HOUSE AND HENRY A. HOUSE, JR., OF BRIDGEPORT,
CONNECTICUT.

RELIEF-VALVE FOR DOOR-CHECKS.

SPECIFICATION forming part of Letters Patent No. 384,907, dated June 19, 1888.

Application filed December 31, 1887. Serial No. 259,468. (No model.)

To all whom it may concern:

Be it known that we, HENRY A. HOUSE and HENRY A. HOUSE, JR., citizens of the United States, residing at Bridgeport, in the county of Fairfield and State of Connecticut, have invented certain new and useful Improvements in Relief-Valves for Door-Checks; and we do hereby declare the following to be a full, clear, and exact description of the invention, such as will enable others skilled in the art to which it appertains to make and use the same.

Our invention relates to devices for controlling the movements of doors and the like, but has special reference to that particular class of devices known as "liquid" and "pneumatic" door-checks. In the manipulation and practical use of said check a serious objection has hitherto existed—namely, the breaking of the casing or piston when the door is suddenly slammed, or when the piston is forced with too great violence against the comparatively unyielding body of air or liquid. This breakage is of course due to the fact that the air or liquid cannot escape through the vent provided fast enough to insure a sufficient yielding to the sudden shock or concussion of the piston.

While our improvement is applicable to either a liquid or a pneumatic check, we have in the drawings shown it as adapted for use in a liquid check, since in this instance not only is a more severe test afforded, but all the operative parts and the construction of the check proper are in accordance with the operation of the parts and the construction of the liquid check shown and described in our Letters Patent No. 367,634, issued August 2, 1887. We will therefore in the present instance enter into no description of said parts and construction, as they form no part of this improvement; but we will refer to certain of said parts according as their function has relation to and materially assists in the understanding of our present improvement.

The object of our invention is to provide a perfectly automatic door-check which shall perform its functions with equal facility in all temperatures, and in which there shall be no danger of breakage due to the sudden concus-

sion or forcing of the piston against the air or liquid.

In the accompanying drawings, which serve to illustrate our invention, Figure 1 is a sectional elevation showing our improved relief-valve in normal position prior to the depression of the piston, while Fig. 2 is a similar view showing the valve raised to afford a free vent for the liquid on the sudden depression of the piston.

Similar letters denote like parts in both the figures of the drawings.

A is the case; B, the central spindle; D, the piston; E, the annular double-inclined cam; 18, the channel in said spindle, having ports *a b*, all constructed and operating precisely as shown and described in our patent aforesaid.

F is the valve-stem, terminating at its lower extremity in a disk-valve, G. This stem extends upward through the spindle and is secured by means of an adjustable screw-cap, H, which latter is run on the upper extremity of the spindle. The stem is secured through the top of the cap by a cross-pin, I, or in any other suitable manner. Near the upper end of the stem is formed a shoulder, J, and around the stem, and confined between this shoulder and the top of the cap, is a coil-spring, K, whereby any upward movement of the stem is rendered resilient. The channel 18 widens out, as seen at *c*, where it leads into the ports *a*, after the manner of a cone, and within this conical passage and immediately above the channel 18 extends the valve-disk G. This disk in normal position is slightly raised away from contact with the wall of the passage, so as to afford an annular exit for the air or liquid.

The regulation of the normal elevation of the stem, and consequently the determination of the size of the annular exit, is accomplished by the manipulation of the threaded cap H.

The operation of our improvement is as follows: Generally when the door is operated to depress the piston B the compressed air or liquid finds ample exit through the ports *b*, the channel 18, and the ports *a*; but when the closing of the door is forced or attempted to be accomplished by a sudden or violent slam the air or liquid thus suddenly compressed beyond

the relieving capacity of the said ports and channel acts against the valve-disk and forces the stem upward, thus widening the channel, and consequently relieving the pressure. The degree to which the pressure may be relieved depends in a measure upon the construction of the walls of the passage which encompasses the valve, since the less pitch that these walls have the more unobstructed will be the exit for the air or liquid when the valve is raised. The spring K returns the valve to its normal position after the pressure on the air or liquid has been relieved. In order to insure the working of the check with proper facility in all temperatures, we make the valve-stem from a material—such as zinc—which has a great difference between the extremes of expansion and contraction. For instance, in cold weather it becomes desirable to close the door quickly, and this is automatically accomplished, because the contraction of the stem opens a freer outlet for the air or liquid.

Where the liquid employed is oil or other lubricant, the expansible and contractible stem is especially advantageous, owing to the fact that cold weather thickens the oil and renders it exceedingly sluggish; but the contraction of the stem compensates for the thickness of the oil, and the flow of the latter through the ports becomes sufficiently free. In other words, by the use of a zinc or other rod which has great expansion and contraction the annular exit around the valve-disk is normally greater in cold temperatures and less in warm temperatures, thereby affording an outlet for the air or liquid automatically freer in low temperatures.

We claim--

1. The combination, with the compressing-piston and the central spindle having ports above and below said piston, and a vertical channel connecting said ports, of the stem suspended from a vertically-adjustable cap, said stem having on its lower extremity a valve-disk which extends immediately over and in close proximity to said vertical channel, and the coil-spring around said stem at the upper end thereof and confined between the cap and a shoulder on the stem, substantially as shown, and for the purposes set forth.

2. The combination of the piston D, the spindle B, having at its lower end ports *a b*, connected by channel 18, having widened conical mouth *c*, said spindle being threaded exteriorly at the upper extremity, the interiorly-threaded cap H, adapted to the threaded end of the spindle, the valve stem F, extending through said spindle and attached to said cap, and having near the upper end a shoulder, J, and on the lower extremity a valve-disk, G, extending immediately over the channel 18 and within the widened conical mouth *c*, and the coil-spring K around the stem between the shoulder J and the top of the cap, substantially as and for the purposes herein shown and set forth.

In testimony whereof we affix our signatures in presence of two witnesses.

HENRY A. HOUSE.
HENRY A. HOUSE, JR.

Witnesses:

S. S. WILLIAMSON,
D. P. KERR.