

J. LOCHER.

AUTOMATIC STOP FOR NUMBER REGISTERS.

No. 456,196.

Patented July 21, 1891.

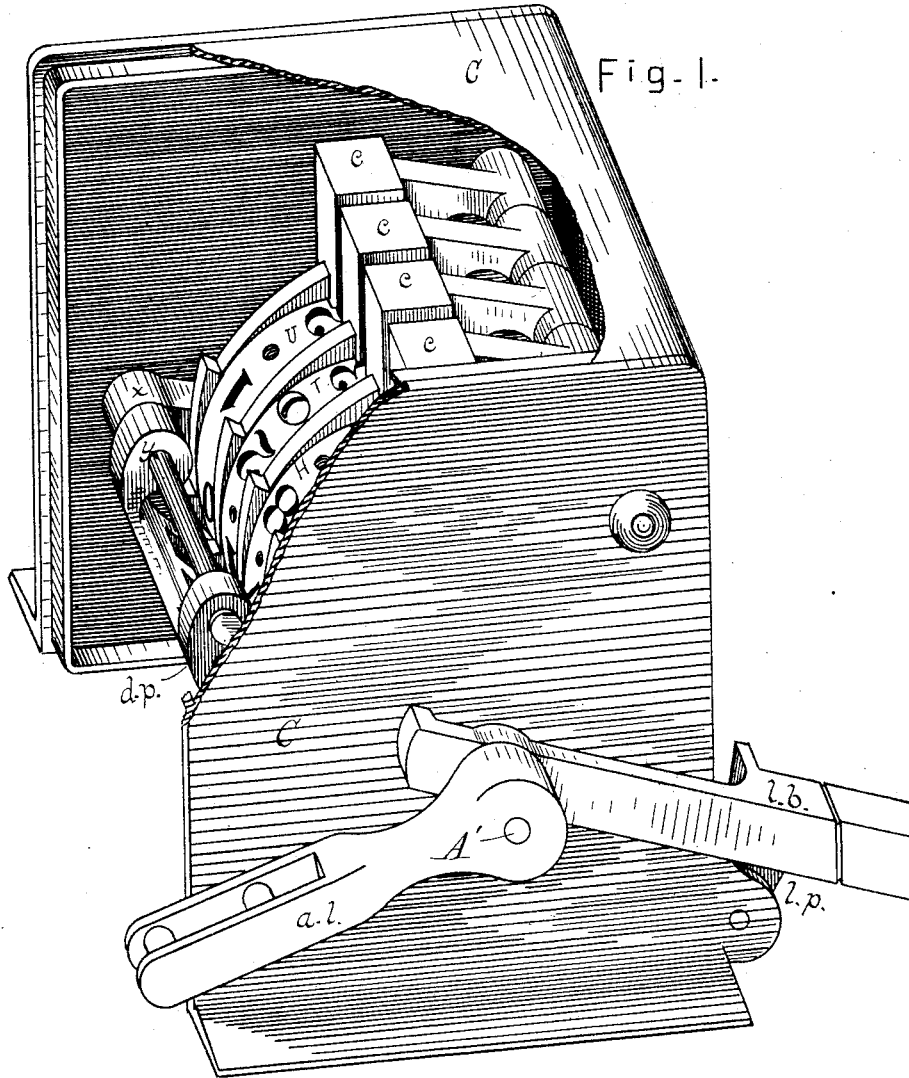

ATTEST
H. S. Landerman
A. Spuehler

INVENTOR
James Locher
 By *L. P. Graham*
 his attorney

J. LOCHER.

AUTOMATIC STOP FOR NUMBER REGISTERS.

No. 456,196.

Patented July 21, 1891.

Fig. 2.

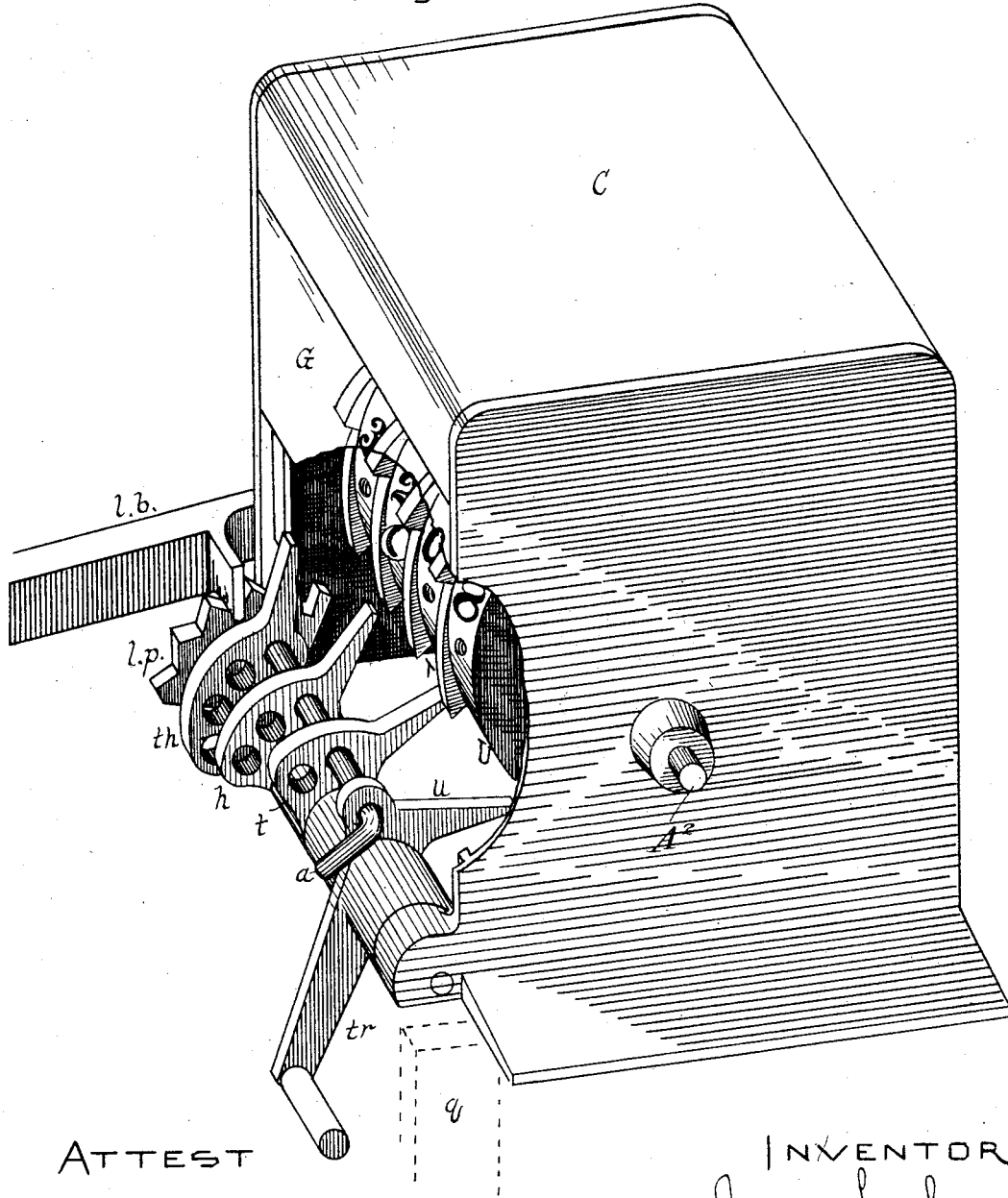

ATTEST

H. Klauerman
A. Spaeth

INVENTOR

James Locher.
 By *L. P. Graham*
 his attorney

J. LOCHER.

AUTOMATIC STOP FOR NUMBER REGISTERS.

No. 456,196.

Patented July 21, 1891.

Fig. 3.

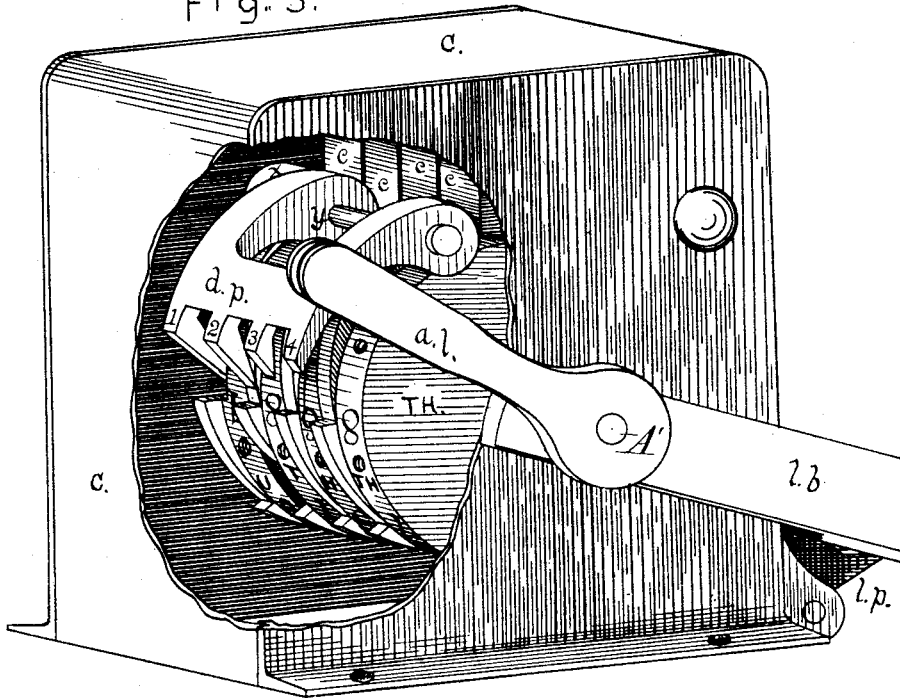

Fig. 4.

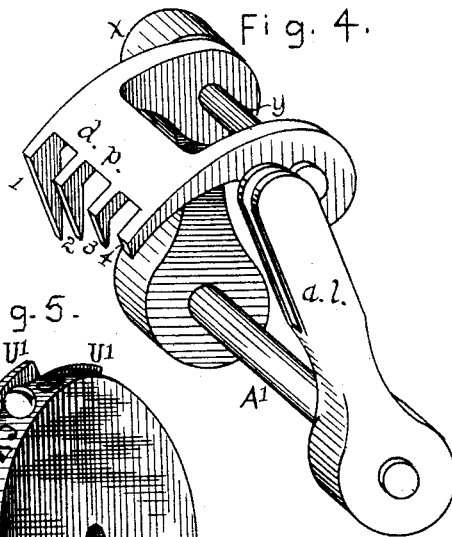
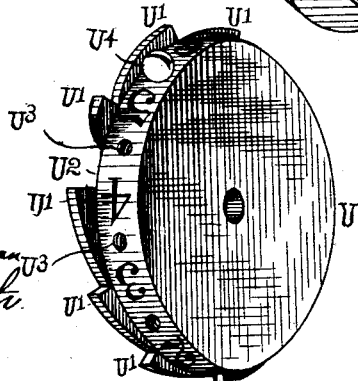

Fig. 5.



ATTEST

H. Shlaudman
A. Spacht

INVENTOR

James Locher
 By *L. P. Graham*
 his attorney

J. LOCHER.
AUTOMATIC STOP FOR NUMBER REGISTERS.

No. 456,196.

Patented July 21, 1891.

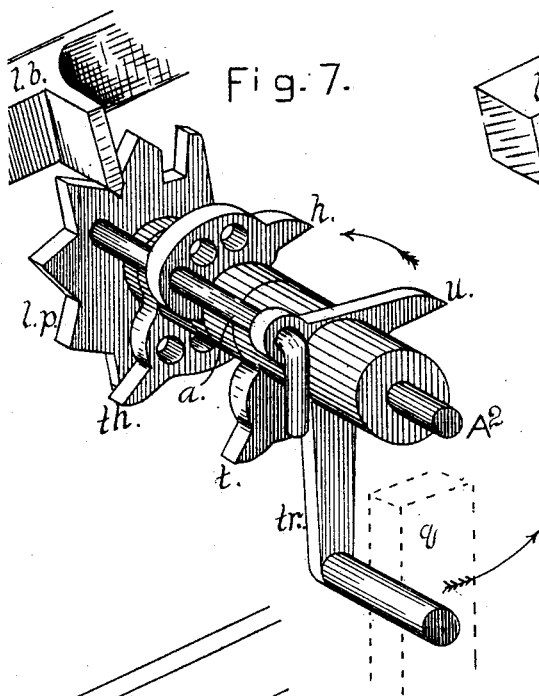

Fig. 7.

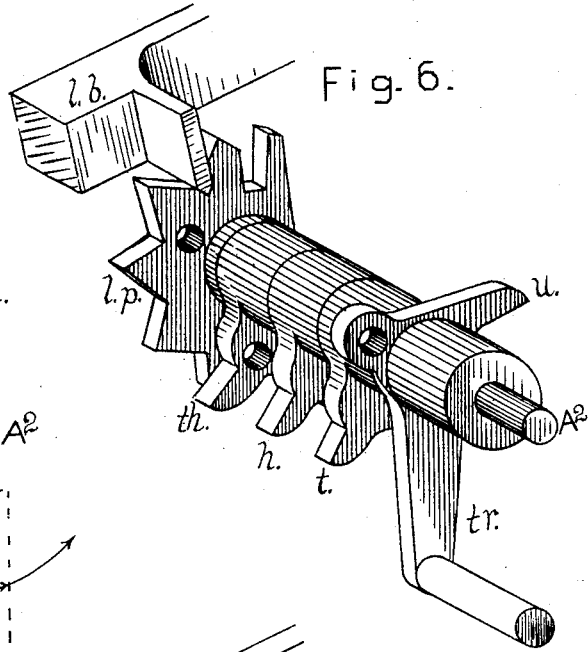

Fig. 6.

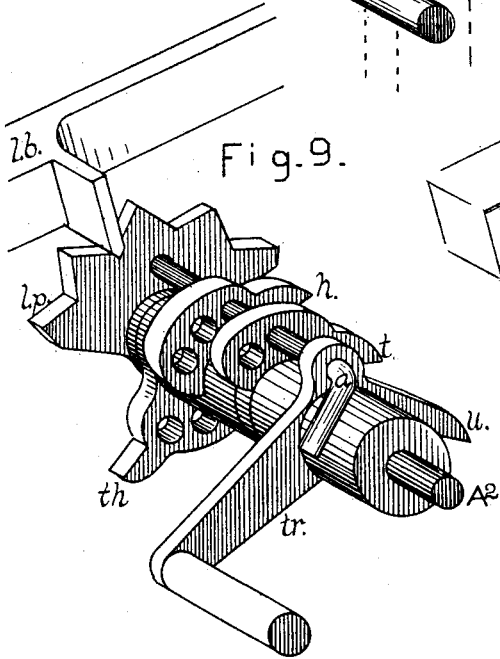

Fig. 9.

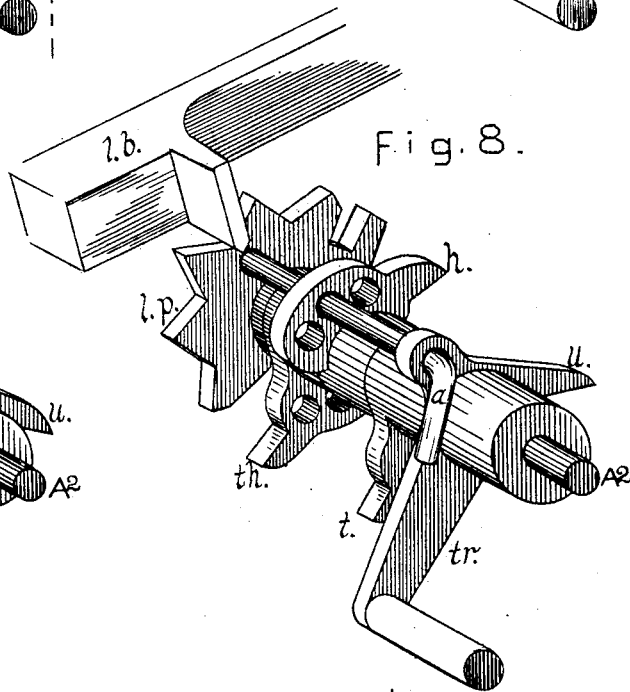

Fig. 8.

ATTEST

H. Shlandman
A. Spueth

INVENTOR

James Locher
By *L. P. Graham*
his attorney

UNITED STATES PATENT OFFICE.

JAMES LOCHER, OF DECATUR, ILLINOIS.

AUTOMATIC STOP FOR NUMBER-REGISTERS.

SPECIFICATION forming part of Letters Patent No. 456,196, dated July 21, 1891.

Application filed May 1, 1888. Renewed January 9, 1891. Serial No. 377,224. (No model.)

To all whom it may concern:

Be it known that I, JAMES LOCHER, of the city of Decatur, county of Macon, and State of Illinois, have invented certain new and useful Automatic Stops for Number-Registers, of which the following is a specification.

My device is especially designed to be used with automatic scales in mills, elevators, and similar establishments; but it is applicable to any machine the number of the operations of which it is desired to register and to definitely and automatically limit.

In the drawings accompanying and forming a part of this specification, Figure 1 represents a register in perspective with the casing broken to expose the wheels, the drive-pawl, and the clicks. Fig. 2 is a perspective view of the device from an opposite direction, showing the stop mechanism. Fig. 3 is especially designed to show the relative construction of the drive-pawl and register-wheels. Fig. 4 shows the drive-pawl and its coacting devices. Fig. 5 represents a register-wheel. Figs. 6, 7, 8, and 9 show the stop mechanism under various conditions of adjustment.

In Figs. 1 and 3 the point of observation is on the same side as the actuating-lever, somewhat above and to the rear of the device. In Fig. 3 the point of observation is somewhat lower than in Fig. 1, and inspection of the drive-pawl is facilitated by carrying the actuating-lever to its highest position. In Fig. 2 the face of the device is obliquely presented and the point of observation is on the side opposite the actuating-lever.

The register mechanism comprises the units-wheel U, the tens-wheel T, the hundreds-wheel H, the thousands-wheel TH, the actuating-lever *a l*, the rod *A'*, which constitutes the prime axis, the arm *x*, the pivot rod *y*, the drive-pawl *d p*, having the impelling-fingers 1, 2, 3, and 4 of differing sizes and conformation, and clicks *c c c c* to prevent backward motion in the wheels and retard their forward motion beyond the throw of the drive-pawl. Each wheel is constructed as shown in Fig. 5, with a single unimportant exception to be hereinafter noted. Each rotates on axis *A'*, each has the numbers from 0 to 9 on its periphery, each has ten ratchet-teeth, as indicated on the units-wheel at *U'*, each has

threaded perforations, as shown in the units-wheel at *U*³, and with the exception of the thousands-wheel each has a depression between two of its ratchet-teeth, as shown in the units-wheel at *U*².

The stop mechanism comprises trip projections adapted to be set in the threaded perforations of the register-wheels, (see *U*¹ in Fig. 5,) a set of adjustable tappets to cooperate with the trip projections, a trip-arm, a lock-bar, and a lock-plate.

The tappet that coacts with the trip projection of the units-wheel is designated by reference-letter *u*. The tappet that coacts with the trip projection of the tens-wheel has *t* for a reference-letter. *h* designates the tappet that coacts with the trip projection of the hundreds-wheel, and *th* designates the tappet that coacts with the trip projection of the thousands-wheel.

l p is the lock-plate.

l b is the lock-bar.

a is the rod that secures the tappets in their various positions of adjustment.

*A*² is the shaft or secondary axis on which the units-wheel tappet and lock-plate are firmly and the other tappets loosely mounted.

q in Figs. 2 and 7 represents by dotted lines an obstruction that the trip-arm *t r* is designed to throw in the path of a moving portion of the device to which the register may be attached. The trip-arm is integral with the units-wheel tappet, as herein shown, though this construction is not entirely essential, and the units-wheel tappet has a single perforation adapted to the adjusting-rod *a*. The tens-wheel tappet has two perforations, the hundreds-wheel tappet has three perforations, and the thousands-wheel tappet has four perforations. The lock-plate has four obtuse-angled depressions, in which the lock-bar bears with a retarding tendency, and an approximately parallel-sided recess, in which the lock-bar falls to make a positive stop. The lock-bar pivots on axis *A'* and has a lateral projection that engages the lock-plate. The lock-plate and the units-wheel tappet are rigidly mounted on their common shaft. The hole in one is coincident with the hole in the other, and when the adjusting-rod *a* is in position in said hole the loose tappet or tappets traversed by the rod are held

firmly in position. Ordinarily the finger 1 of the drive-pawl d p operates alone on the ratchet-teeth of the units-wheel. When a depression U^2 in said wheel, as seen in Fig. 5, is reached, the finger 1 falls into said depression and permits the finger 2 to operate on the tens-wheel, as shown in Fig. 3. Each complete rotation of the units-wheel effects a one-tenth rotation of the tens-wheel. At the termination of a complete rotation of the tens-wheel the finger 2 falls into a recess in said wheel and permits the finger 3 to move the hundreds-wheel, and so the operation continues until at the termination of one thousand operations of the drive-pawl the thousands-wheel TH will make a one-tenth rotation, and the reading across the face of the wheels through the glass G will be "1,000." Each oscillation of the actuating-lever a l , which is designed to be connected with an oscillating portion of the machine, the movements of which it is desired to register, imparts a partial rotation to the units-wheel. At each complete rotation of the units-wheel the tens-wheel moves one point. At ten complete rotations of the units-wheel and one complete rotation of the tens-wheel the hundreds-wheel moves one point, and at one hundred rotations of the units-wheel, ten rotations of the tens-wheel, and one rotation of the hundreds-wheel the thousands-wheel will move one point. From this it will be seen that the recesses of the wheels into which the fingers of the drive-pawl fall must be uniformly contiguous to a certain number, in order that the reading shall be correct, and that the relation of the drive-pawl to the face of the register must be considered in the selection of the number, in order that the reading shall be properly presented. With the drive-pawl in the position shown in the drawings the recesses of the wheels must be contiguous to the number 4, in order that a cipher shall be presented when a wheel is thrown by a finger in a recess.

If it should be desirable to stop a machine after ten or fewer operations, a trip projection would be set in the units-wheel, as shown in Fig. 5, the loose tappets could be discarded, as shown in Fig. 6, and the lock-bar would be placed in the retarding-depression of the lock-plate next the lock-recess, as also shown in Fig. 6. Then as the number 5 was presented, as heretofore set forth, the trip projection would strike tappet u , carrying the lock-plate into position to receive the lock-bar in its locking-recess, and also forcing the trip-arm against the stopping device of the machine, to which the device is attached.

In order to stop the machine at any even hundred number of operations, let a trip projection be placed in the desired position in the hundreds-wheel, remove the trip projection from the units-wheel, place the lock-bar in the retarding-depression of the lock-plate next the lock-recess, as in the foregoing example, and place the hundreds-wheel tappet in the position shown in Fig. 7. The units-

wheel tappet will then remain inoperative, for the reason that there is no trip projection in position to throw it, and when the desired number of hundreds is reached the tappet h will be thrown with precisely the result heretofore specified.

Suppose that it is desired to have five hundred and eight operations of the machine to which my device is attached. Trip projections will then be placed one after 5 in the hundreds-wheel and one after 8 in the units-wheel. The lock-bar will be placed in the second retarding-depression of the lock-plate, counting from the locking-recess, and the tappets will be arranged as shown in Fig. 8. The units-wheel tappet will now be too low to engage the trip projection, and the operations will continue until the completion of 500, when the trip projection of the hundreds-wheel will throw tappet h . The ensuing rotation will carry the retarding-depression next the lock-recess under the lock-bar and also carry tappet u in position to be struck by the trip projection of the units-wheel.

In Fig. 9 the stop mechanism is set to stop at a number containing units, tens, and hundreds, as 235. In this example it will be seen that three partial rotations of the lock-plate will be necessary to carry the lock-recess under the lock-bar, and that three tappets are arranged to be struck consecutively.

In Fig. 2 arrangements are made to stop at a number containing tens, hundreds, thousands, and units, as 3,265, and the thousands-wheel tappet and hundreds-wheel tappet have already been struck.

From the above it will be understood that in adjusting the lock-plate no account is taken of ciphers, but that the number of integers determines what retarding-depression shall be placed under the lock-bar. For instance, the numbers 5, 50, 500, and 5,000 would each require the lock-bar to rest in the retarding-depression next the lock-recess, the numbers 25, 205, and 2,005 would each require the lock-bar to rest in the second retarding-depression, the numbers 235 and 2,305 would each require the lock-bar to rest in the third retarding-depression, while 1,234 would require the lock-bar to rest in the fourth depression. The same rule applies to the tappets. None are used for ciphers. One is used for each integer in the number to be considered, and whatever number of tappets is used they must be arranged to be moved consecutively, the thousands-wheel tappet first, the hundreds-wheel tappet second, and so on.

I claim as new and desire to secure by Letters Patent—

1. A stop device for number-registers, comprising a set of wheels properly marked with numerals, a common axis on which said wheels are mounted, trip projections adapted to be removably secured to the wheels, a set of tappets, an axis on which the tappets are mounted and on which they have rotative adjustment, and a trip-arm adapted to partake of

the operative motion of the tappets, as and for the purpose set forth.

2. A stop device for number-registers, comprising a set of wheels properly marked with numerals, a common axis on which said wheels are mounted, trip projections adapted to be removably secured to the wheels, a set of tappets, a lock-plate having a number of retarding-depressions and a lock-recess, an axis on which the tappets and lock-plate have rotative adjustment, a lock-bar adapted to the lock-plate, and a trip-arm adapted to partake of the operative motion of the tappets, as and for the purpose set forth.

3. In stop mechanism for number-registers,

in combination with the wheels U, T, H, and TH, having threaded peripheral perforations, trip projections, as U¹, adapted to the perforations of the wheels, tappets *u*, *t*, *h*, and *th*, lock-plate *l p*, lock-bar *l b*, adjusting-rod *a*, and trip-arm *t r*, as and for the purpose set forth.

In testimony whereof I sign my name in the presence of two subscribing witnesses.

JAMES LOCHER.

Attest:

I. D. WALKER,
L. P. GRAHAM.