

(No Model.)

W. C. BRYANT.
ELECTRIC SWITCH.

No. 457,300.

Patented Aug. 4, 1891.

Fig. 1.

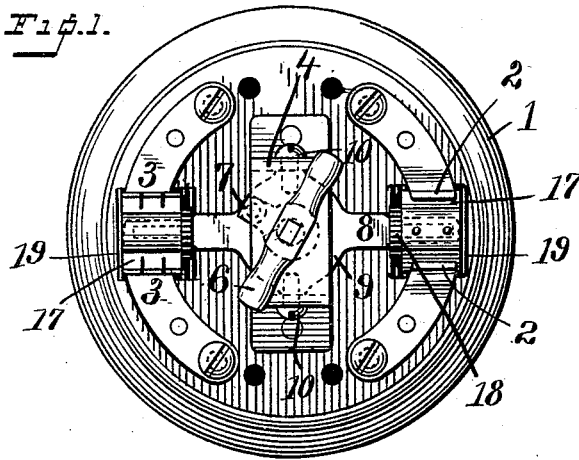

Fig. 2.

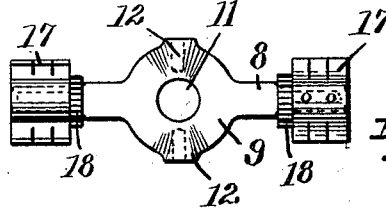

Fig. 4.

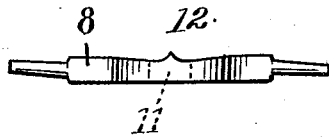

Fig. 5.

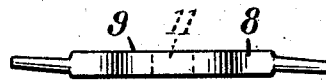
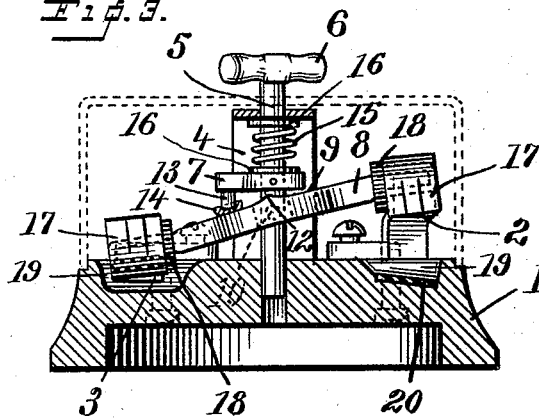

Fig. 3.



WITNESSES

C. M. Newman,
Jna M. Anderson.

INVENTOR

Waldo C. Bryant
By J. M. Wooster atty.

UNITED STATES PATENT OFFICE.

WALDO C. BRYANT, OF BRIDGEPORT, CONNECTICUT, ASSIGNOR TO THE
BRYANT ELECTRIC COMPANY, OF SAME PLACE.

ELECTRIC SWITCH.

SPECIFICATION forming part of Letters Patent No. 457,300, dated August 4, 1891.

Application filed April 8, 1891. Serial No. 388,143. (No model.)

To all whom it may concern:

Be it known that I, WALDO C. BRYANT, a citizen of the United States, residing at Bridgeport, in the county of Fairfield and State of Connecticut, have invented certain new and useful Improvements in Electric Switches; and I do hereby declare the following to be a full, clear, and exact description of the invention, such as will enable others skilled in the art to which it appertains to make and use the same.

My invention relates to the class of switches or cut-outs operating with a turn-handle, which are specially constructed to open or close an electric circuit with a quick snapping action, the contact-bar when moved past a certain position in either direction having an additional movement produced by a spring which acts wholly independent of the handle, the opening and closing movements taking place instantly as soon as the operating-arm has been moved past a certain dead-center line.

The object of my invention is to provide a switch of this class which shall be simple, economical, and durable in construction, thoroughly practical in use, and which will operate to open or close the switch by a slight movement of the handle in either direction.

With these ends in view my invention consists in the special combination and improvements in the details of construction, which I will now proceed to describe, and then specifically point out in the claims.

In the accompanying drawings, forming part of this specification, Figure 1 is a plan view of my novel switch, the cap being removed; Fig. 2, a plan view of the contact-bar detached; Fig. 3, a central vertical section of the base, showing the operative parts of the switch in elevation in the closed position, the cap being indicated by dotted lines, and Figs. 4 and 5 are edge views illustrating modifications in the laying out of the cams upon the table.

1 denotes the base, which is made of wood or porcelain, as may be preferred; 2 2, the terminals upon one side; 3 3, the terminals upon the opposite side; 4, the yoke, which is rigidly secured to the base; 5, the spindle, which turns freely in the yoke and the base;

6, the handle, and 7 the operating-arm, both of which are rigidly secured to the spindle.

8 denotes the contact-bar, the central portion of which consists of a table 9, the opposite edges of which are pivoted to the yoke.

10 denotes the studs upon which the table is pivoted. At the center of the table is an opening 11, through which the spindle passes freely, and upon the upper surface thereof are cams 12, the highest points of said cams being coincident with the pivotal points of the table. The operating-arm is provided with a pin 13, and between said pin and the table is a shoe 14, which rocks upon the pin, thereby reducing friction to the minimum. The operating-arm is held down, so as to bear with the necessary power upon the table by means of a strong coil-spring 15, which surrounds the spindle, washers 16 being interposed between the ends of the spring and the yoke and the operating-arm, respectively. At the ends of the contact-bar are brushes 17, and between said brushes and the contact-bar the usual insulating-pieces 18.

It will be observed that I have illustrated my invention as applied to a double-pole switch, and that the terminals upon one side are much higher than those upon the other side. This is in order to complete the circuit by tilting the contact-bar in one direction and to break the circuit by tilting the contact-bar in the opposite direction, less than half a revolution of the spindle being required to make or break the circuit. Recesses 19 are formed in the base to receive the ends of the contact-bar and brushes when the contact-bar and table are tilted. Upon the side having the raised terminals—that is, the side upon which the contact-bar is moved downward to break the circuit—is placed a pad 20, of leather or felt, to receive the blow of the contact-bar and brush. This deadens the sound of the contact and does away with the sharp snapping sound that has been unavoidable in switches of this class, as heretofore constructed.

In Fig. 3 I have shown the contact-bar and table as having a plane surface with raised cams at opposite sides at the pivotal points, the highest points of the cams being moderately sharp angles.

In the form illustrated in Fig. 4 I have shown the surface of the table as curving downward and then upward to form the cams, the cams being the highest point upon the table, the surface of which is lowest at points intermediate between the cams and points at right angles thereto.

In the form shown in Fig. 5 the surface of the table is a plane without any raised portions, the cams being entirely dispensed with.

Either form may be used without departing from the principle of my invention. In practice I preferably use either the form illustrated in Fig. 3 or that in Fig. 4—that is, a form having raised angular cams coincident with the pivotal points of the table—for the reason that the use of the cams gives a slightly quicker movement to the contact bar in use, it being obvious that the contact-bar will remain in position until the bearing portion of the operating-arm, preferably a shoe, in use has been moved to and slightly past the dead-center line—that is, the apex of one of the angular cams; or, if the cams are dispensed with, past one of the pivotal points.

Having thus described my invention, I claim—

1. In an electric switch, the combination, with a tilting contact-bar having a central table formed integral therewith, of a rotary vertically-movable spindle having an operating-arm, and a spring acting to hold said arm in contact with the table, so as to tilt the contact-bar quickly when said arm is moved past either of the pivotal points.

2. The combination, with a tilting contact-bar having a central table formed integral therewith, of a rotary vertically-movable spin-

dle having an operating-arm, a spring acting to hold said arm in contact with the table, and a rocking shoe interposed between the operating-arm and the contact-bar, substantially as described.

3. The combination, with a tilting contact-bar having a central table provided with angular cams 12 coincident with the pivotal points, of a rotary vertically-movable spindle having an operating-arm and a spring acting to hold said arm in contact with the contact-bar, substantially as described.

4. The combination, with a yoke and a tilting contact-bar having a central table, the opposite sides of which are pivoted to the yoke, of a rotary vertically-movable spindle having a contact-arm provided with a pin adapted to engage the surface of the table, a rocking shoe interposed between said pin and the table, and a spring bearing upon the operating-arm and acting to hold the shoe in contact with the tilting contact-bar.

5. The combination, with the yoke and a tilting contact-bar having a central table pivoted to the yoke and provided with cams 12, of a rotary vertical spindle having an operating-arm provided with a pin 13, a rocking shoe upon said pin adapted to engage the table, and a spring 15, bearing upon the operating-arm and acting to tilt the contact-bar when said arm is moved past either of the pivotal points.

In testimony whereof I affix my signature in presence of two witnesses.

WALDO C. BRYANT.

Witnesses:

A. M. WOOSTER,
INA M. NICKERSON.