

G. F. HUTCHINS.
TAKE-UP FOR LOOMS.

No. 459,173.

Patented Sept. 8, 1891.

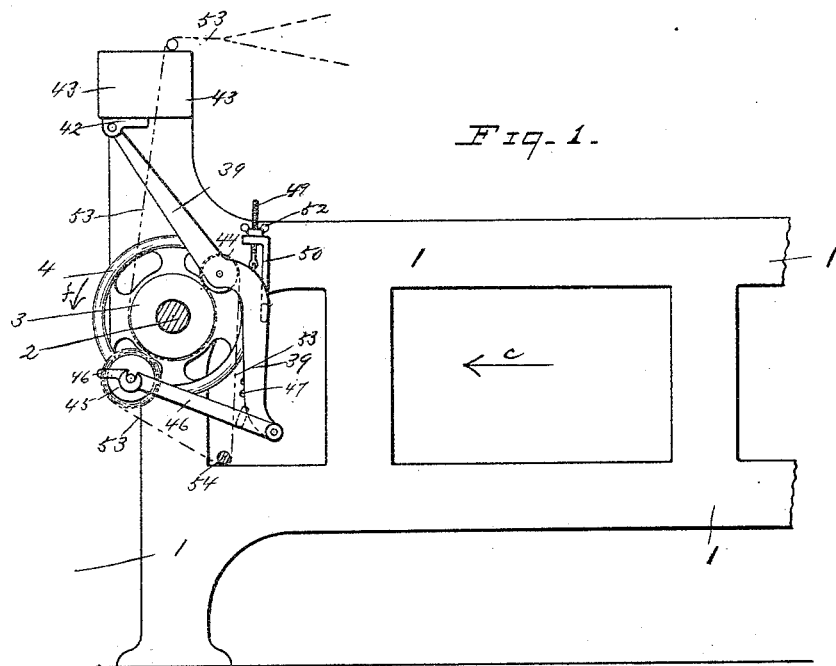

Fig-1.

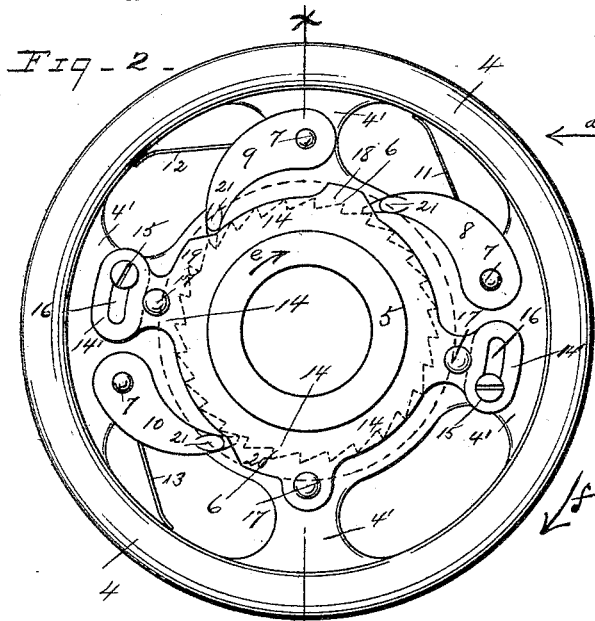

Fig-2.

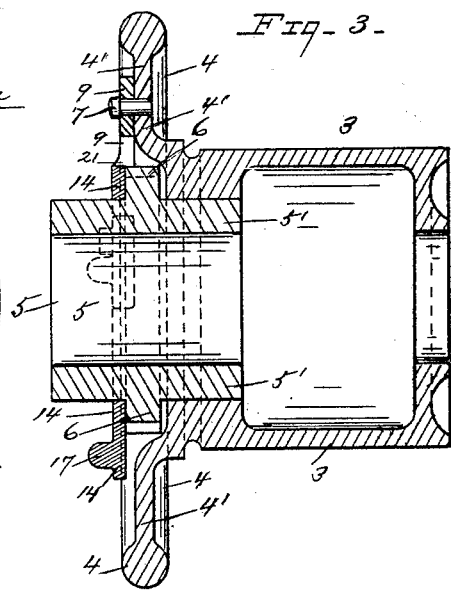

Fig-3.

Witnesses
 Clinton Alvord
 W. M. Wattie

Inventor
 George F. Hutchins
 By his Attorney
 John C. Dewey

G. F. HUTCHINS.
TAKE-UP FOR LOOMS.

No. 459,173.

Patented Sept. 8, 1891.

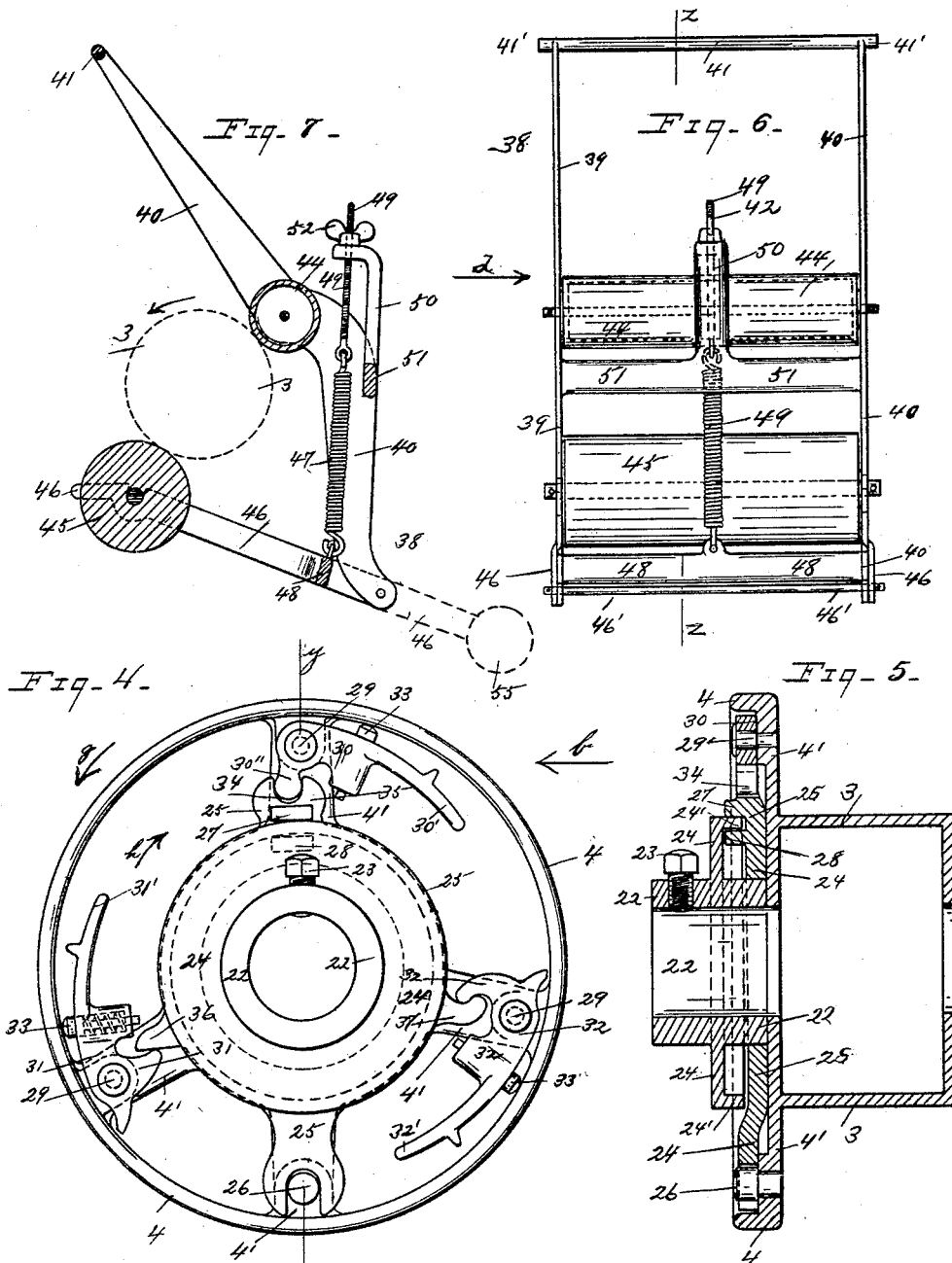

Witnesses
Edwin Alvord.
W. M. Watte

Inventor
George F. Hutchins
By his Attorney
John C. Dewey

UNITED STATES PATENT OFFICE.

GEORGE F. HUTCHINS, OF WORCESTER, MASSACHUSETTS, ASSIGNOR TO
THE KNOWLES LOOM WORKS, OF SAME PLACE.

TAKE-UP FOR LOOMS.

SPECIFICATION forming part of Letters Patent No. 459,173, dated September 8, 1891.

Application filed October 20, 1890. Serial No. 368,764. (No model.)

To all whom it may concern:

Be it known that I, GEORGE F. HUTCHINS, a citizen of the United States, residing at Worcester, in the county of Worcester and State of Massachusetts, have invented certain new and useful Improvements in Take-Ups for Looms; and I do hereby declare that the following is a full, clear, and exact description thereof, which, in connection with the drawings making a part of this specification, will enable others skilled in the art to which my invention belongs to make and use the same.

My invention relates to take-up and winding mechanism for looms, and more particularly for narrow-ware looms, as tape and ribbon looms, in which the take-up shaft carries an individual take-up or "sand-roll" for each section of material or web woven. In said class of looms it is required that each take-up roll may be independently disconnected from the take-up shaft, so as to be turned in either direction thereon; and my invention further relates to the winding up of the woven goods after they have passed over the take-up roll, and to an improved tension mechanism for winding up the woven goods.

The object of my invention is to produce a simple and effective mechanism combined with each take-up roll, by means of which said roll may be connected with or disconnected from the take-up shaft at pleasure, to allow of said roll being revolved independently of said shaft, and, further, to produce a simple and effective tension mechanism to cause the woven goods to be wound smoothly and evenly on the winding-up roll.

My invention consists in certain novel features of construction and operation of a take-up mechanism and a winding mechanism, as will be hereinafter fully described.

Referring to drawings, Figure 1 is a sectional side elevation of a portion of a narrow-ware loom with my improvements applied thereto. Fig. 2 represents an end detail of the take-up mechanism. Fig. 3 is a central longitudinal section on line *x x*, Fig. 2, looking in the direction of arrow *a*, same figure. Fig. 4 is a detail corresponding to Fig. 2, showing a modification of my take-up mech-

anism. Fig. 5 is a central longitudinal section on line *y y*, Fig. 4, looking in the direction of arrow *b*, same figure. Fig. 6 is a rear side elevation of the tension and winding mechanism detached, looking in the direction of arrow *c*, Fig. 1. Fig. 7 is a vertical section on line *z z*, Fig. 6, looking in the direction of arrow *d*, same figure. Figs. 2 to 7, inclusive, are represented on an enlarged scale.

I will first describe my improved take-up mechanism or clutch mechanism applied to the take-up roll to allow of the same being connected with or disconnected from the take-up shaft at pleasure.

In the accompanying drawings, 1 is a portion of the loom side of a narrow-ware loom.

2 is a take-up shaft, which is driven in the usual manner by belt or gears (not shown) in the direction of the arrow *f*, Fig. 1.

Upon the take-up shaft 2 are loosely supported at regular intervals corresponding to the number of individual webs to be woven on the loom a take-up or sand-roll 3, only one of which is shown in the drawings. On one end of the sand-roll 3 is secured a hand-wheel 4. Said hand-wheel 4 may be made integral with roll 3, if preferred, as shown in Fig. 3.

Within the hand-wheel end of the roll 3 extends loosely the hub 5' of a ratchet-collar 5. (See Fig. 3.) The collar 5 is fast on the take-up shaft 2 and is provided with ratchet-teeth 6, extending out therefrom. (See Fig. 2.)

On the arms 4' of the hand-wheel 4 are pivoted by pins 7 pawls 8, 9, and 10, and each pawl is set in a different position on the ratchet-teeth 6, so that each pawl will work on a tooth in turn and no two will work at the same time, which is equivalent to dividing the ratchet into three times the number of teeth, as will be understood by those skilled in the art. The three pawls 8, 9, and 10 are held down into engagement with the ratchet-teeth 6 by means of springs 11, 12, and 13, secured to the hand-wheel 4, as shown in Fig. 2.

Onto the outer end of the hub 5' of the ratchet-collar 5 is mounted loosely a cam-plate 14. Said cam-plate 14 is held in position on hand-wheel 4 against the toothed flange of the ratchet-collar 5 by means of screws 15, passing through elongated slots 16 in exten-

sions 14' of the cam-plate 14, said screws 15 being screwed into the arms 4' of the hand-wheel 4.

The cam-plate 14 is preferably provided with knobs 17, extending out therefrom, by means of which it may be turned around on the hub 5' of the ratchet-toothed collar 5 for the length of the slots 16. Said cam-plate 14 is provided with three cam-surfaces 18, 19, and 20, corresponding to the pawls 8, 9, and 10. Said cam-surfaces 18, 19, and 20 extend beyond the ratchet-teeth 6, and are so placed that when the plate 14 is moved around on the hub 5' in the direction of arrow *e*, Fig. 2, within the hand-wheel, the said cams will pass under small lugs or projections 21 on the pawls 8, 9, and 10 and raise the pawls and disconnect them from the ratchet-teeth, thus allowing the hand-wheel 4, fast to the sand-roll 3, to be turned around in either direction independently of the ratchet or toothed collar 5, fast on the shaft 2, and of said shaft.

The operation of the take-up mechanism shown in Figs. 2 and 3 is as follows: The take-up shaft 2 and the ratchet-collar 5, fast thereon, are driven in the direction of arrow *f*, Figs. 1 and 2. The strain of the woven goods on the take-up roll 3 is in the opposite direction from the arrow; but as long as the pawls 8, 9, and 10 are engaged with the ratchet-teeth 6 the take-up roll 3 and hand-wheel 4, fast thereon, will revolve with the take-up shaft. When it is desired to disconnect the take-up roll 3 from the take-up shaft 2 for any purpose, the cam-plate 14 is moved around in the direction of the arrow *e*, Fig. 2, so that the cam-surfaces 18, 19, and 20 thereof will engage the lugs 21 on said pawls and raise the same out of engagement with the teeth 6, thus disconnecting the roll 3 and hand-wheel 4 from said ratchet-teeth and allowing said roll to revolve in either direction on the take-up shaft. When it is desired to connect the take-up roll 3 with the take-up shaft, the cam-plate 14 is revolved in the opposite direction into the position shown in Fig. 2, disengaging the cam-surfaces from the pawls and allowing the same to drop into and engage the teeth 6.

I will now describe the take-up mechanism shown in Figs. 4 and 5, which is a modification of the mechanism shown in Figs. 2 and 3. The take-up roll 3 and hand-wheel 4 correspond to the take-up roll and hand-wheel shown in Figs. 2 and 3, but instead of having the ratchet-collar 5 I substitute a collar 22, secured on the shaft 2 by a screw 23 and provided with a flanged disk 24. Loosely supported on the inner end of the hub 22' of the collar 22 is a gripping-lever 25, pivoted at its lower end by a pin 26 on the arm 4' of the hand-wheel 4 and provided at its upper end with lugs or gripping-jaws 27 and 28, adapted to extend over and grip the rim 24' of the disk 24 (see Fig. 5) when said gripping-lever 25 is moved in one direction and to release and not grip the rim 24' of the disk 24 when said gripping-lever 25 is moved in the opposite direction,

as will be understood by those skilled in the art. Upon the arms 4' of the hand-wheel 4 are pivoted by pins 29 the pawls 30, 31, and 32. Said levers or pawls are provided with spring-actuated pins 33, adapted to press against the inner edge of the rim of the wheel 4 and throw the ends 30', 31', and 32', respectively, inwardly, as shown in Fig. 4. The opposite end 30'' of the pawl 30 is adapted to extend into an opening or notch 34 in a lug 35, extending up from the gripping-lever 25. The gripping-lever 25 is also provided with lugs 36 and 37 for engagement with the pawls 31 and 32, respectively, as shown in Fig. 4.

The operation of the mechanism shown in Figs. 4 and 5 will be readily understood by those skilled in the art.

The revolution of the take-up shaft 2, carrying the flanged disk-collar 22, fast thereon, in the direction of the arrow *g*, Fig. 4, will cause the jaws 27 and 28 of the gripping-lever 25 to grip and hold the flanged disk 24, so that said gripping-lever 25 and the hand-wheel 4 and roll 3 will revolve with the take-up shaft 2. When it is desired to disconnect the take-up roll 3 and hand-wheel 4 from the take-up shaft and the flanged disk collar 22, fast thereon, either one of the pawls 30, 31, or 32 are grasped at their engaging ends 30', 31', and 32' and moved outward against the action of the spring-actuated pins 33, causing the gripping-lever 25 to be moved in the direction of arrow *h*, Fig. 4, and the jaws 27 and 28 to release their grip on the rim 24', allowing the roll 3 and hand-wheel 4 to be moved around on the shaft 2 independently of said shaft. By releasing the pawl which was grasped the action of the spring-actuated pin 33 will cause the pawl to return to its normal position and to move the gripping-lever 25 in the opposite direction from that above described into the position shown in Fig. 4, causing the jaws 27 and 28 to again grip the flanged disk 24 and cause the take-up roll 3 to be connected with and revolve with the take-up shaft.

I have shown three pawls for operating the gripping-lever for sake of convenience in taking hold of the hand-wheel at three different points; but two pawls will produce the same result and may be made use of, if preferred. By combining the three levers or pawls 30, 31, and 32 with the gripping-lever 25, as above described and as shown in Fig. 4 of the drawings, it will be seen that said gripping-lever will be operated to release the action of the gripping-jaws 27 and 28 on the flange-disk 24 by operating any one of the three levers or pawls 30, 31, and 32. I have also shown one gripping-lever and one set of gripping-jaws; but, if preferred, two or more gripping-levers may be used having thereon gripping-jaws.

I will now proceed to describe the tension and winding-up mechanism. (Shown in Figs. 6 and 7.) A frame 38, consisting of the side bars 39 and 40 and the top bar 41, is pivoted by means of the projecting ends 41' of the top bar 41 in stands 42, secured to the under

side of the breast-beam 43 (see Fig. 1) in the ordinary way. A roll 44 is supported between the arms 39 and 40 and rests upon the take-up roll 3. (See Fig. 7.) The winding-roll 45 is supported in the outer end of the frame 46, pivoted at its inner end by a rod 46' to the lower end of the frame 38. (See Fig. 6.) The frame 46, carrying the winding-roll 45, is retained in its position by means of a spring 47, secured at its lower end to a bar 48, extending between the side bars of the frame 46, and secured at its upper end to an adjusting-screw 49, supported in an arm 50, extending up from the cross-bar 51 of the frame 38. Said screw 49 has a thumb-screw 52 thereon, bearing on the upper side of the arm 50, by means of which the screw 49 is screwed up or down to regulate the tension of the spring 47.

The operation of the tension and winding mechanism above described is as follows: The spring 47 holds up the pivoted frame 46 and presses the cloth-roll 45 against the under side of the take-up roll 3, and the resulting friction will cause the roll 45 to revolve with the take-up roll 3. Referring to Fig. 1, the fabric coming from the loom is represented by the broken lines 53. Said fabric first passes around the take-up roll 3, then over the roll 44 to the polished shaft 54, located below the winding mechanism, and then to the cloth-roll 45, which is turned by its friction against the revolving take-up roll 3, as above stated. The end of the fabric is attached to the roll 45, and the same is wound upon said roll. The increased diameter of the roll 45 as the fabric is wound thereon stretches the spring 47, thus allowing the cloth-roll as the material is wound thereon to move away from the take-up roll and at the same time maintain the friction between the take-up roll and cloth-roll and cause the fabric to be wound smoothly and evenly on the cloth-roll. The weight of the frame 38 and the frame 46, pivoted to its lower end, will cause the roll 44 to bear upon the take-up roll 3 and to remain in frictional contact therewith, so that said roll 44 will be revolved with said take-up roll 3, as above stated. The spring 47 connecting the two frames 38 and 46 together, said frames carrying, respectively, the rolls 44 and 45, extending upon opposite sides of the take-up roll 3, serves to draw the rolls 44 and 45 toward each other and increase the friction of the same on the take-up roll 3.

It will be understood that the details of construction of my improved take-up mechanism and winding mechanism may be varied from what is shown and described, if desired.

Instead of employing a spring 47 to hold the winding-roll 45 in yielding contact with the take-up roll 3, a weight 55 may be employed, secured upon the extended arms of the frame 46, as shown by broken lines, Fig. 7.

Having thus described my invention, what I claim as new, and desire to secure by Letters Patent, is—

1. In a loom, the combination, with the take-up shaft and a flanged disk collar fast thereon, of a take-up roll provided with a hand-wheel carrying one or more pawls, and a gripping-lever provided with jaws to grip the flanged disk collar, said gripping-lever operated by said pawls to release the flanged disk collar, for the purpose stated, substantially as set forth.

2. In a loom, the combination, with the take-up shaft and the take-up roll supported thereon, of the tension and winding-up mechanism consisting of a frame pivoted at its upper end to the loom-frame and carrying a roll resting on the take-up roll, and a second frame pivoted to the lower end of said first-mentioned frame and carrying a roll bearing against the take-up roll and held in yielding contact with said take-up roll, for the purpose stated, substantially as set forth.

3. In the take-up and winding mechanism of a loom, the combination, with the take-up roll and a frame pivoted at its upper end to the loom-frame and carrying a roll resting on the take-up roll, of a second frame pivoted to the lower end of the first-mentioned frame and carrying a roll held in yielding contact with the take-up roll by a spring or weight, and said spring or weight, for the purpose stated, substantially as set forth.

4. The combination, with the take-up roll and a frame pivoted to the loom-frame and carrying a roll resting on the take-up roll, of a second frame pivoted to the first-mentioned frame and carrying a roll bearing against the take-up roll, and an adjustable spring connecting the two frames together, for the purpose stated, substantially as set forth.

GEORGE F. HUTCHINS.

Witnesses:

JOHN C. DEWEY,
EDMUND F. SEYMOUR.