

R. UHL.
MITER SAW.

No. 493,667.

Patented Mar. 21, 1893.

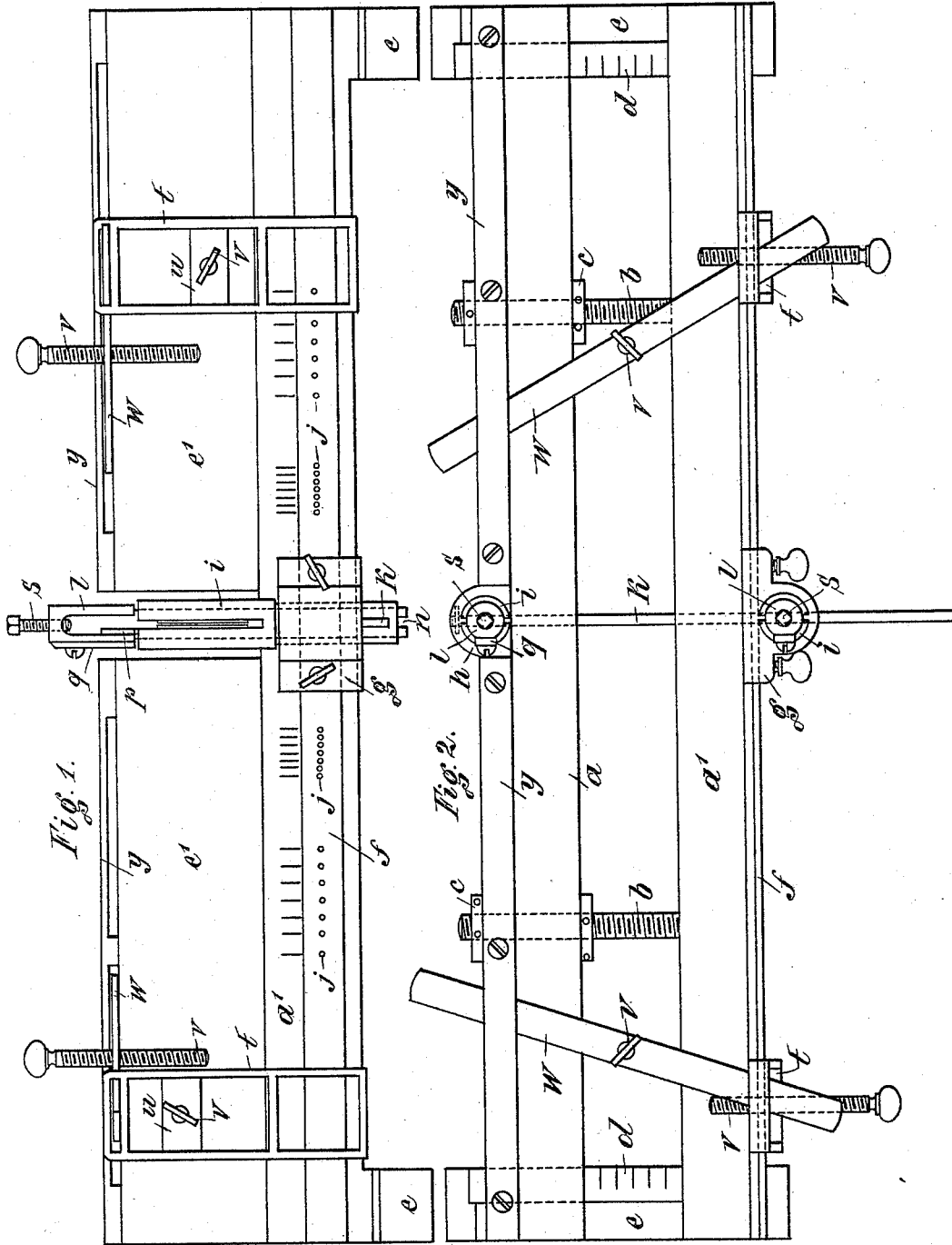

Witnesses:
 E. B. Bolton
 H. Kusterer

BY

Inventor:
 Roman Uhl
R. Uhl
 His Attorneys

(No Model.)

4 Sheets—Sheet 2.

R. UHL.
MITER SAW.

No. 493,667.

Patented Mar. 21, 1893.

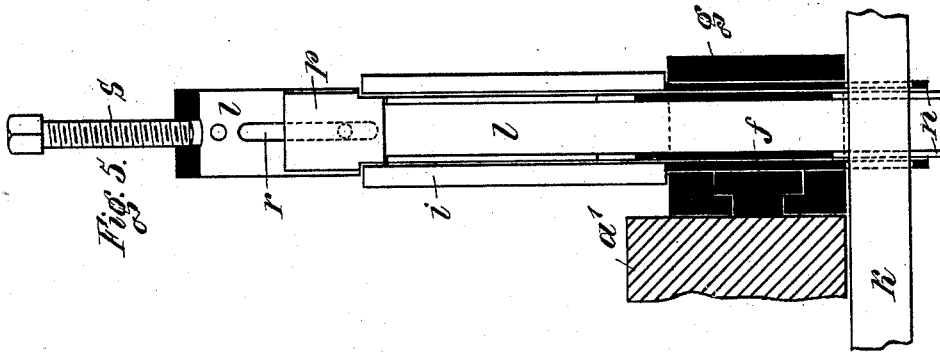

Fig. 5.

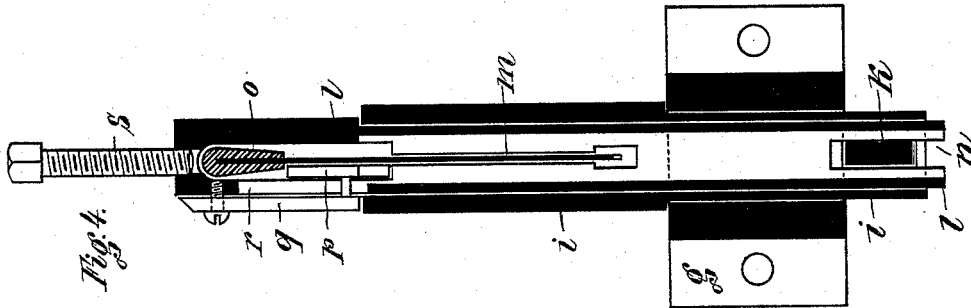

Fig. 4.

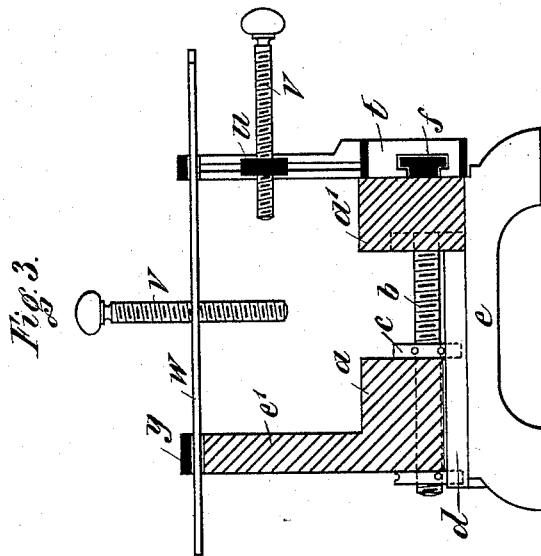

Fig. 3.

Witnesses:
E. B. Bolton
H. Kusterer.

By

Inventor:

Roman Uhl
Richard R.
his Attorneys.

R. UHL.
MITER SAW.

No. 493,667.

Patented Mar. 21, 1893.

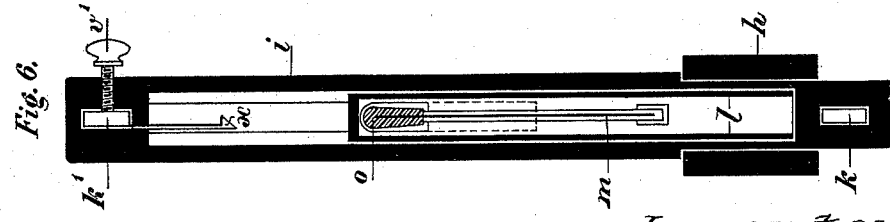
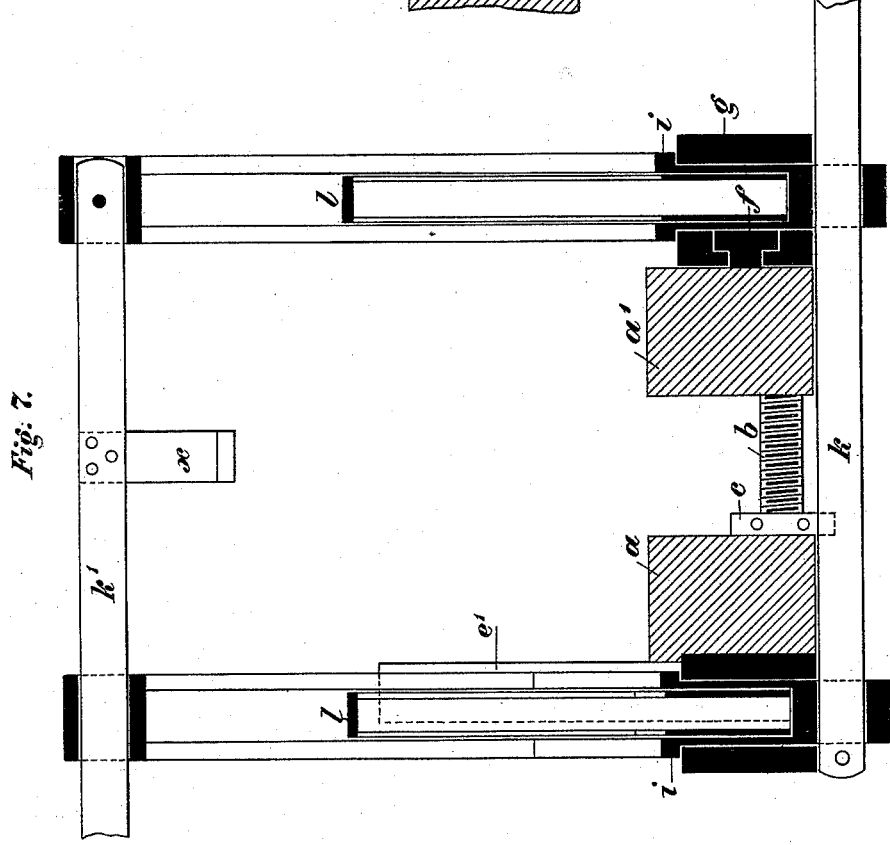
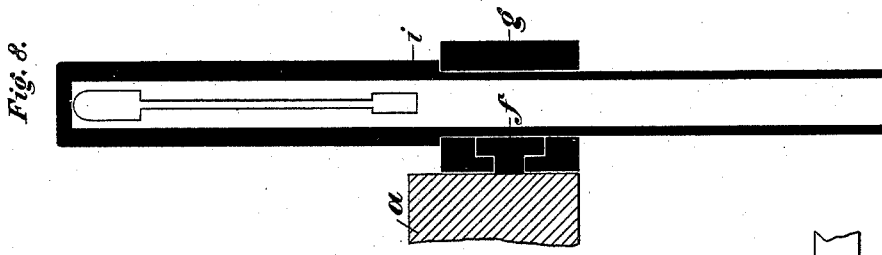

Witnesses:
 E. B. Bolton
 H. Kusterer.

Inventor:
 Roman Uhl
 By *R. Neumann*
 his Attorneys.

R. UHL.
MITER SAW.

No. 493,667.

Patented Mar. 21, 1893.

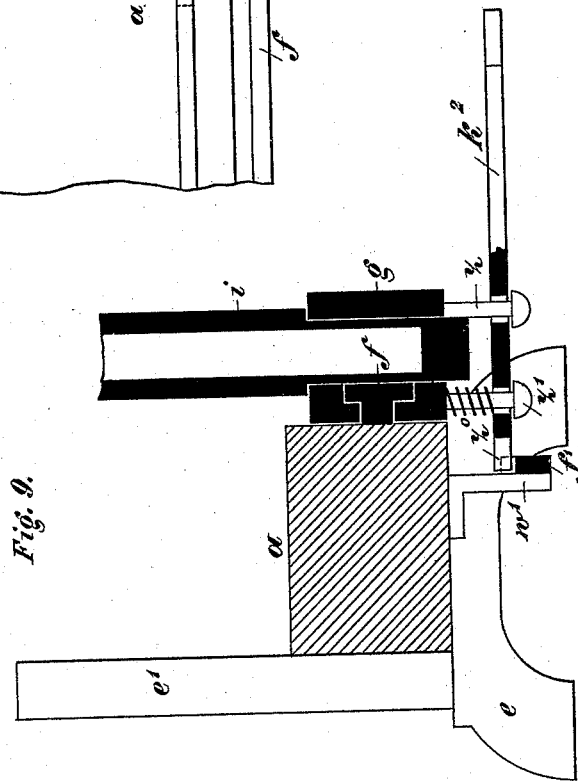
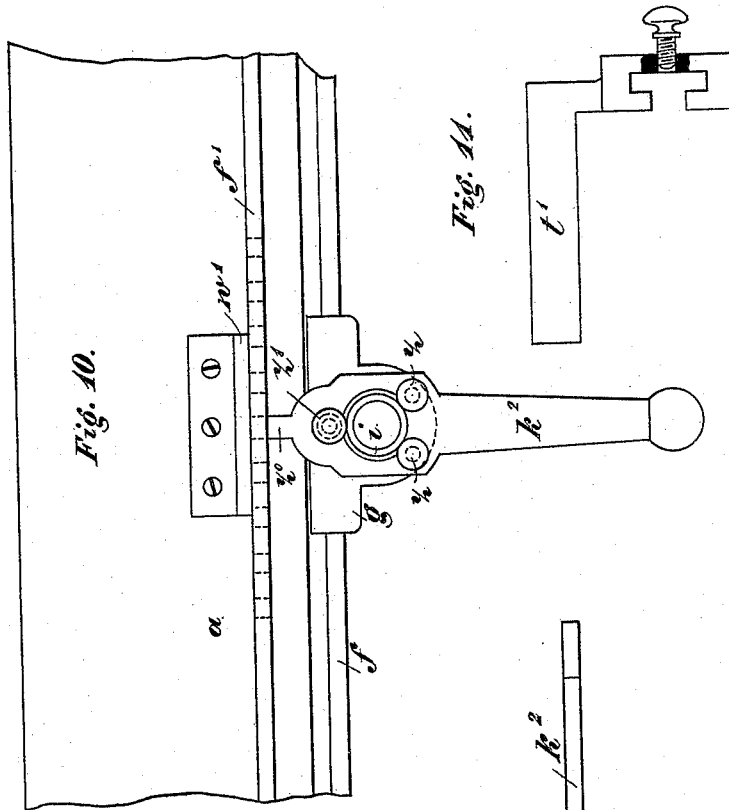

Witnesses:

E. B. Kolton
H. Huston.

By

Inventor:
Roman Uhl

Richardson
his Attorneys.

UNITED STATES PATENT OFFICE.

ROMAN UHL, OF HAUSACH, GERMANY.

MITER-SAW.

SPECIFICATION forming part of Letters Patent No. 493,667, dated March 21, 1893.

Application filed November 2, 1891. Serial No. 410,675. (No model.) Patented in Germany March 29, 1891, No. 59,110.

To all whom it may concern:

Be it known that I, ROMAN UHL, a subject of the Emperor of Germany, residing at Hausach, Baden, Germany, have invented certain new and useful Improvements in Miter-Saws, of which the following is a specification.

Features of this invention have been patented to me in Germany under the date of March 29, 1891, No. 59,110.

The object of the present invention is a miter saw, especially adapted for the cutting of quoins.

In order to make my invention more clearly understood I have shown in the accompanying drawings means for carrying the same into practical effect.

Referring to said drawings: Figure 1 is a front view of a machine embodying my invention. Fig. 2, is a ground plan. Figs. 3, 4 and 5 are detail views. Figs. 7, 8, 9, 10 and 11 are details of modifications.

Referring to said drawings: like letters of reference refer to like parts in the specification.

In this machine the molding support can be regulated in width and is divided for this purpose into two parts *a* and *a'* (Figs. 2 and 3.) Part *a'* is stationary on the legs *e e* provided with dovetail guides, while part *a* is arranged movably on these guides *d* which are divided into equal parts. The fastening of part *a* is done by means of the screw *b* and nut *c* on part *a*. The fence or leader *e'* for the molding is on part *a*. On the front side of part *a'* a T-shaped guide *f* is fastened along its entire length, on which the saw regulating block *g* is movably fixed. Besides this guide divisions are made on said wall corresponding with the different quoining angles, and with which the notches *j* on guide *f* for the setting screws of the block *g* correspond exactly. For convenience sake a division can be made on the surface of the support *a'* and corresponding with the former. In the regulating block *g* on one part and in a box *h* attached stationary to the middle of the back of part *a* on the other part guide cylinders *i* are laid which are capable of rotating. Below their beds a setting lever *k* of corresponding length is

pushed through these cylinders, whereby they are held fast in their beds. In the cylinder *i* a guide bolt *l* is set, which is as the latter provided with guiding slots for the saw *m* (Figs. 4 and 5). These bolts are provided at their lower ends with a perpendicular incision *n*, between which the lever *k* comes to lie, whereby involuntary rotations of the bolts *l* in the cylinders *i* are prevented and the slots guiding the saw, are kept precisely parallel to one another. The slots of the bolts are widened in the part above the cylinders to correspond with the stiffening back *o* of the saw. To the side in the widened slot there is an adjoint piece *p*, which is connected slide like with a ledge *q* on the outside of the bolt by means of a pin, as the connecting pins are guided in separate slots *r* of the bolts. These adjoint pieces *p* on which the back of the saw rests when working (Fig. 4) are however for general use fastened by screwing the ledge *q* to the bolt *l*. The height of the adjoint pieces *p* can, by means of filing, always be so regulated, that the teeth of the saw in use hardly touch the molding support *a* and *a'*, whereby the unavoidable incisions in other miter saws into the table are avoided.

As after each sharpening of the saw and accordingly the filing of the beds *p* the spaces between the saw back and the upper rim of the slot of the bolts become larger, whereby the equal horizontal guiding of the saw when working would be lost, the bolts *l* are provided with setting screws *S*, by means of which the perfect guide can always be re-established. By means of the setting lever *k* connected with the guiding cylinders the same can be brought to any desired quoining angle, in which it is held fast by tightening the screws of the setting block *g*. To both sides of the latter there is on the T-shaped guide a vertical frame like slide *t* (Figs. 1 and 3) which is provided with a plate *u* which can be shoved up and down. These plates have correspondingly long clampscrews *v* by means of which the molding &c. to be cut is pressed and held fast against the fence *e'*. The slides *t* which have the same height as the fence *e'*, have at their upper end a slot like bearing

to hold a correspondingly long rail w , which is laid in the screwed up stirrup y of the joint piece e' . These rails have also screws v and the piece to be sawed can be held against the support a and a' by means of this. The miter sawing machine described distinguishes itself from others, besides by the very practical fastening of the piece to be cut, principally by the most exact, regular and easily regulated saw guide and by the support which can be regulated.

In Figs. 6 and 7 the bolts are no more on top of the cylinder i , but are set into the same and can be moved up and down. The latter are not open at the bottom but are closed by a short core piece on which the setting lever k is shoved. To better secure the parallel position of the two cylinders and to avoid undesired movements of the same when working, a horizontal rail k' is put through the upper end of the cylinder i , which is fastened on the front cylinder by means of a pin, while the rear one is movable on the same and can also be connected securely with the same by a settingscrew v' . The adjoint piece p of the bolts l and the ledges q are entirely omitted here, and the saw back o rests on the narrow guide slots of the saw (Fig. 6.) Each time when filing the saw, the resting points of the same are correspondingly filed. About in the middle of the rail k' a spring stop hook x is arranged in which the saw can be hung up by its back o when laying down the piece to be sawed. A further modification is shown in Fig. 9. There the support a is not movable, but of one piece. The notches of the guide f are omitted, also the setting screws on the setting block g and the long setting lever k . In place of the latter a short pressure lever k^2 is used, which rests movably in the downward running pins z and z' of the setting block g . Pin z' is provided with a spring which constantly presses the lever k^2 downward. The peg z^o of the latter is therewith always inserted in a notch of the rod f' , which is fastened by means of angle pieces w' along the bottom surface of the support a . This rod is provided with as many notches as miter angles are marked on the support, whereby the latter and the notches correspond with each other. To displace the saw the lever k^2 is pressed, whereby its peg z^o is raised from the respective notch of the rod f' , whereupon the setting block with the cylinders and the saw can be set. At the desired quoining angle the lever k^2 is let loose, which then drops with its peg into the corresponding notch of the rod f' in which it is held fast by the spring of the pin z' .

A still simpler form of machine is obtained by using the single support with the last described setting arrangement, omitting the fastening arrangement t, u, v, w, y for the work piece. The bolts l are then also put away with and the cylinders themselves are given the slotlike saw guide shown in Fig. 6,

with the saw back support of the bolts (Fig. 8.) The cylinders are arranged movably up and down in the setting block g that is the box h . The lever k^2 is as seen in Fig. 10, perforated at the corresponding point, so that the downward going cylinder, when cutting, meets with no hindrance. The legs e of the machine are higher than in the other described machines correspondingly to the part of the cylinder i projecting from the guiding block. In all machines angle l' , which is movable or can be set fast, can if necessary be placed on the guide f or the fence e' Fig. 11, so that the work piece can be pushed against it when larger number of pieces of equal length are to be cut.

I claim—

1. In combination the supporting legs, the saw, a main support therefor adjustable in width on said legs, a guide on said support and a block movable thereon, said block carrying the saw, substantially as described.

2. In combination the supporting legs, the saw, a main support therefor, formed in two parts adjustable toward and from each other on said legs, a fence for the molding on one part a guide on the other part and a block adjustable along the said guide and carrying one end of the saw, substantially as described.

3. In combination the saw, the two part adjustable support, the means for sustaining said support arranged below the same and having guides to permit adjustment laterally, but not longitudinally of the two part support, the guide on one part of the adjustable support, and the block movable along the said guide and carrying the saw, substantially as described.

4. In combination the supporting legs, the saw, the main support adjustable in width on said legs, the guide on the said support, the block carrying one end of the saw and arranged to slide on said guide and the revoluble cylinders i , one of which is carried by the said block, substantially as described.

5. In combination the supporting legs, the saw, the main support formed in two parts adjustable toward and from each other on said legs, the guide on one of said parts the block for the saw on the guide and the cylinders i and guiding bolts therein, one of said cylinders and bolts being carried by the block, substantially as described.

6. In combination, the saw, having a back, the main supporting means, the slotted bolts l through which the saw reciprocates and the means for regulating the height of the saw consisting of the adjustable pieces p carried within the bolts and the adjusting means for the pieces p extending outside the bolts, substantially as described.

7. In combination, the saw, the slotted cylinders for guiding the same, the main support, the guide way thereon the block carrying one of said cylinders movable along the

guide way and carrying and adjusting the
saw, the said cylinders having additional
openings through them, and the setting lever
is secured to one cylinder and passing loosely
5 through the opening in the other and being
independent of the means for carrying the
cylinders, substantially as described.

In testimony that I claim the foregoing as
my invention I have signed my name in pres-
ence of two subscribing witnesses.

ROMAN UHL.

Witnesses:

JAKOB UHRICH,
HUGO VETTER.