

(No Model.)

H. T. FIELD.
CAR FENDER.

No. 494,524.

Patented Mar. 28, 1893.

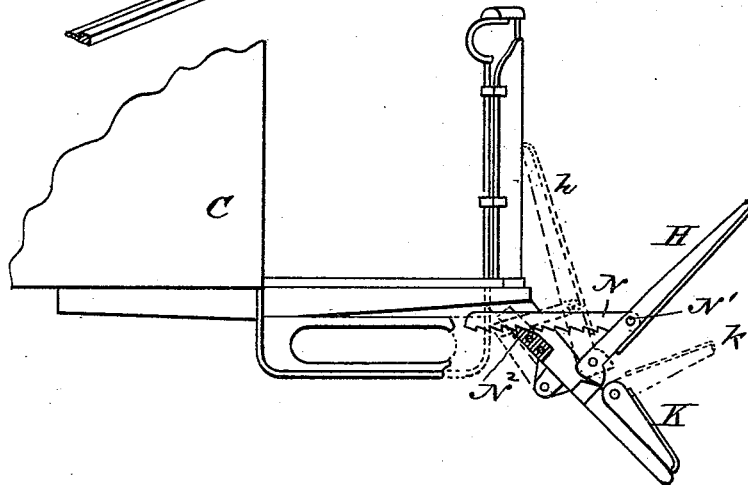
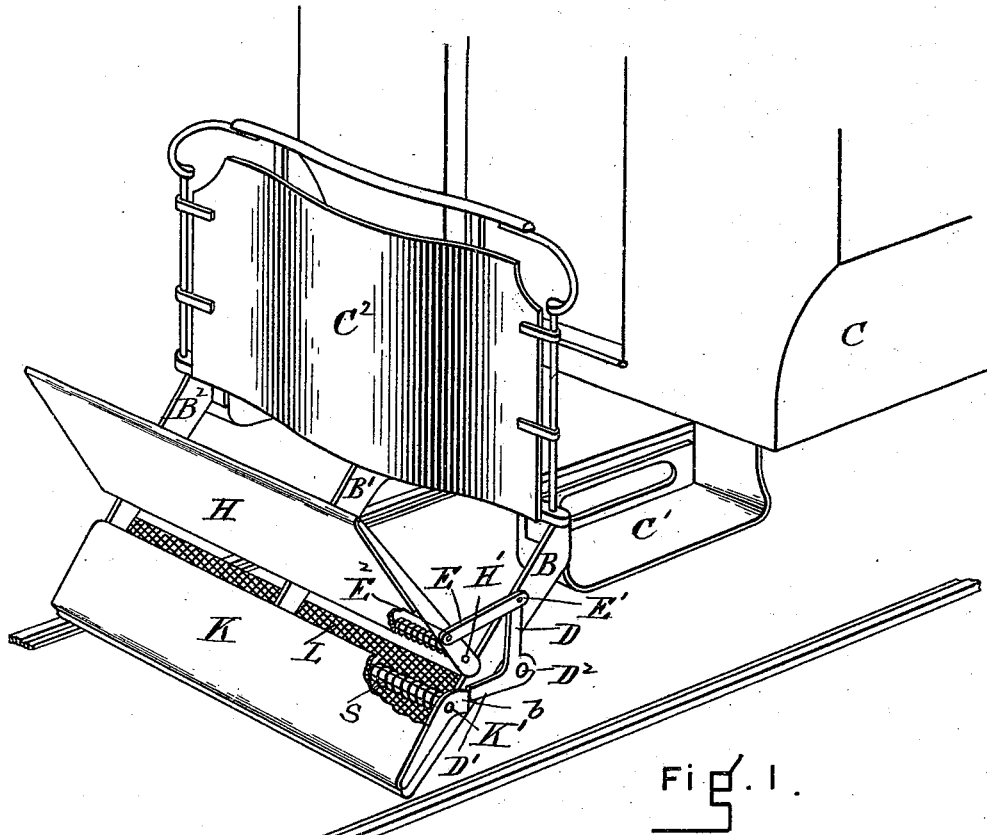

WITNESSES
Frank H. Parker
William H. Perry

FIG. 2. INVENTOR
Horace T. Field

UNITED STATES PATENT OFFICE.

HORACE T. FIELD, OF BOSTON, MASSACHUSETTS.

CAR-FENDER.

SPECIFICATION forming part of Letters Patent No. 494,524, dated March 28, 1893.

Application filed May 20, 1892. Serial No. 433,750. (No model.)

To all whom it may concern:

Be it known that I, HORACE T. FIELD, of Boston, in the county of Suffolk and State of Massachusetts, have invented a new and useful Improvement in Car-Fenders, of which the following, taken in connection with the accompanying drawings, is a specification.

This invention relates to that class of fenders that are used on the ends of street cars for the purpose of preventing any one from being seriously injured by the cars coming in contact with them, that is, the fender is supposed usually to push forward the persons whom it may come in contact with, and to continue to push them forward and keep them from under until it is possible to stop the car.

The object of my invention is to so improve the ordinary fender that the person whom it comes in contact with will be lifted bodily from the track and carried along in comparative safety. This object I attain by the mechanism shown in the accompanying drawings, in which—

Figure 1, is a perspective view, showing one end of a car, with my improved fender attached. Fig. 2 shows in side elevation the same parts, the view being supposed to be taken from the other side of the car from which the perspective view in Fig. 1 is taken.

C, C', C², represent the end of a car, from which projects downward and forward three or more strong rigid bars B, B', B²; these bars are inclined at quite an angle with the track. The lower ends of the said bars are not intended to touch the track or the road bed, but to come as near it as is practical. Extending from the lower ends of these bars B, B', B², upward to nearly half their length, I have a strong frame work and netting, indicated at L, Fig. 1; this netting is firmly attached to the bars.

K, is a shield lying over the netting L, and is hinged to the bars B, as indicated at K', so that the shield K may, under certain circumstances, swing upward, as indicated by dotted lines at *k*, Fig. 2.

S, is a strong spiral spring, so connected with the swinging shield K, that unless the said shield is locked down, the said spring will throw it upward into its dotted position *k*, Fig. 2. For locking the shield K down, I pro-

vide a shoulder *b*, Fig. 1, connected to it and so arranged in connection with the bent lever latch D' D (pivoted at D²) that when the latch is in position shown in Fig. 1, then the shield K must retain its normal position, that is, the position shown in full lines in Figs. 1 and 2; but if the end D' of the latch is thrown upward, it will clear the shoulder *b*, and thus allow the spring S to throw the shield K upward into its dotted position *k*, Fig. 2.

H is a second shield, pivoted at H', and extends from the upper edge of the shield K to a considerable height. The normal position of the shield H is shown in full lines in Figs. 1 and 2. This shield is connected by a link E, pivoted at E² to the shield H, and at E' to the bent lever latch D, D', so that if the shield H is from any cause thrown backward, it will, acting through the link E, throw the upper end D of the bent lever latch backward, thus throwing the latch end D' upward, clearing it from the shoulder *b* on the shield K, thus allowing the shield K to swing upward. The shield H is provided with a spring adapted to hold it steadily in position against the pull of the ratchet link N, said link N being pivoted to H at N', Fig. 2; this ratchet link N engages with a detent at N², firmly attached to the frame of the car, or to one of the bars B, B', B². The spring that actuates the shield H is very weak, not intended to resist any considerable strain, but simply to serve to hold the shield H in place. The shield H when swung backward on its pivot H', may occupy the position indicated by the letter *h*, Fig. 2; in this position it is held by the ratchet link N and the detent N².

In the drawings, I have shown but a single ratchet link N, but if desirable a number of them may be used; the same may be said of the bent lever latch device D, D'.

My device is intended to act as follows, the parts, that is the two shields K and H occupying the position shown in full lines. Now if the fender comes in contact with a person, the person will be thrown upward onto the shield K, and back and against the shield H. In hitting the shield H it, the shield, will be thrown backward, thus unlatching the point D' from the shoulder *b*, and allowing the shield K to be forced upward; this will lift the per-

son from the road bed and retain him in safety until the car can be stopped, that is, the two shields will remain in the positions indicated by dotted lines *k*, *h* of Fig. 2.

5 If from any cause the shield K should fail to take up the person in danger, then the frame work and netting L would be of great utility in saving from serious injury.

I claim—

10 In a car fender, the combination of a lower

swinging shield K, adapted to be operated by a spring, and controlled by mechanism connected to an upper shield H: with an upper shield H, all operating together substantially as described and for the purpose set forth.

HORACE T. FIELD.

Witnesses:

WILLIAM EDSON,
WILLIAM SEARS.