

S. R. BRIGGS.  
FIRE ESCAPE.

No. 522,703.

Patented July 10, 1894.

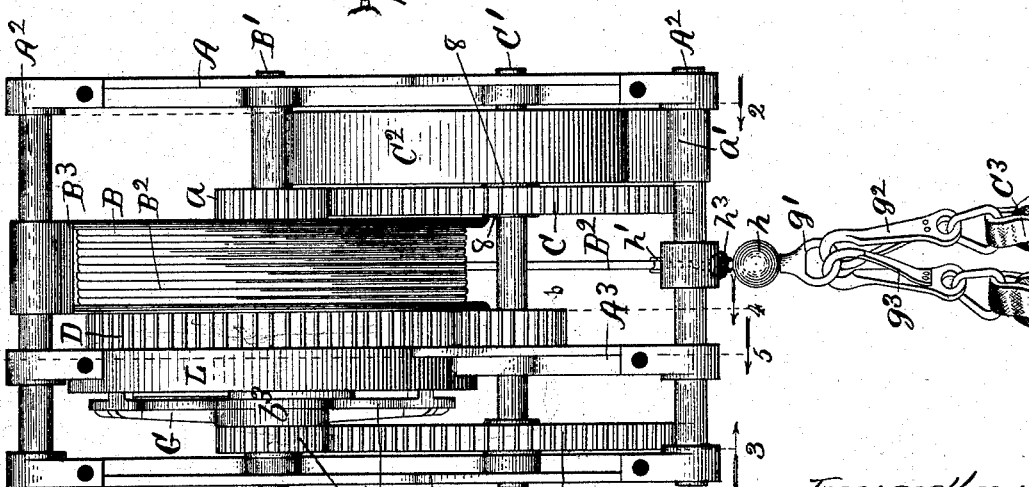
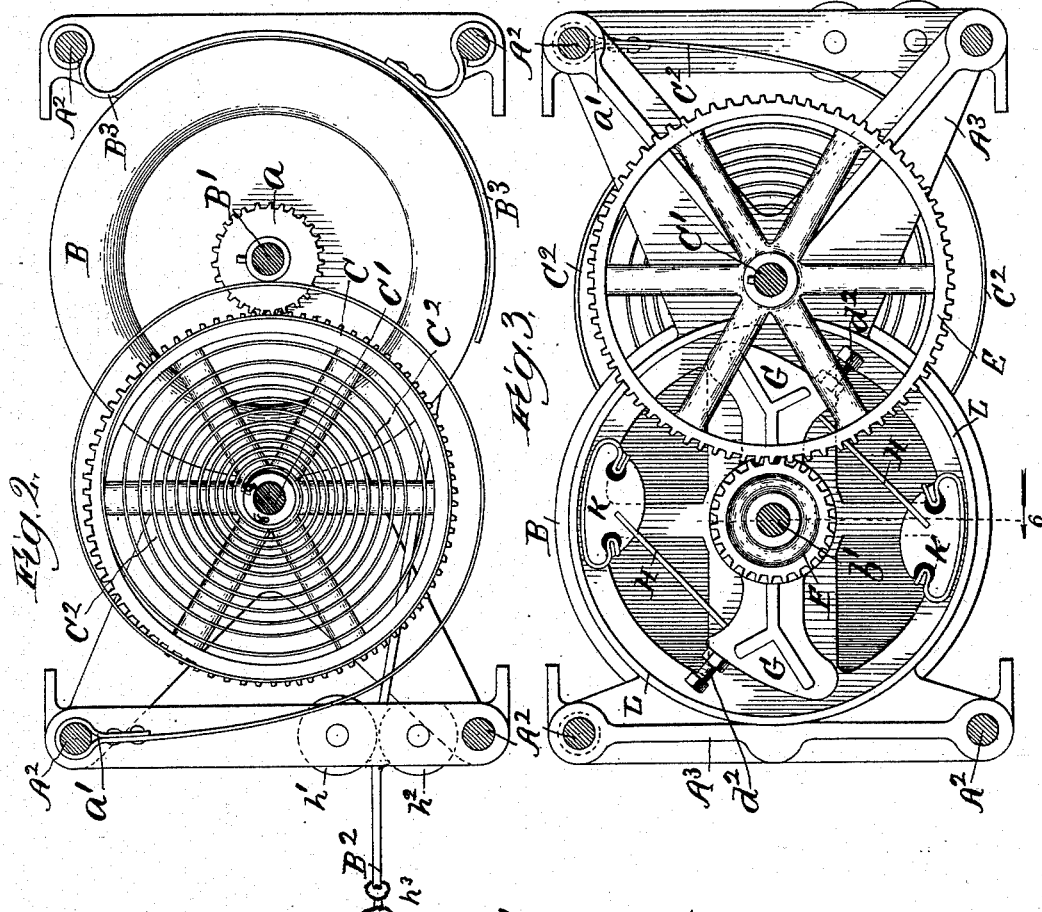

Witnesses  
*Chas. Claydon*  
*Clifford H. White*

*Fig. 1.*

Inventor:  
*S. R. Briggs.*  
 By *L. B. Boyland* *Att'y*

S. R. BRIGGS.  
FIRE ESCAPE.

No. 522,703.

Patented July 10, 1894.

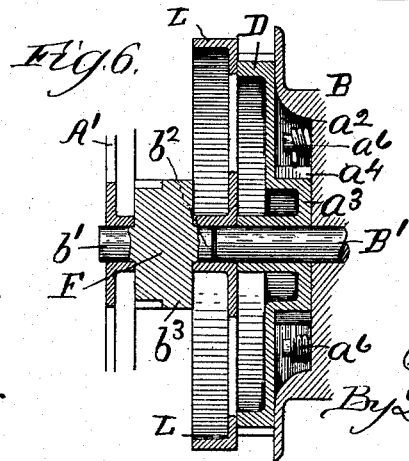
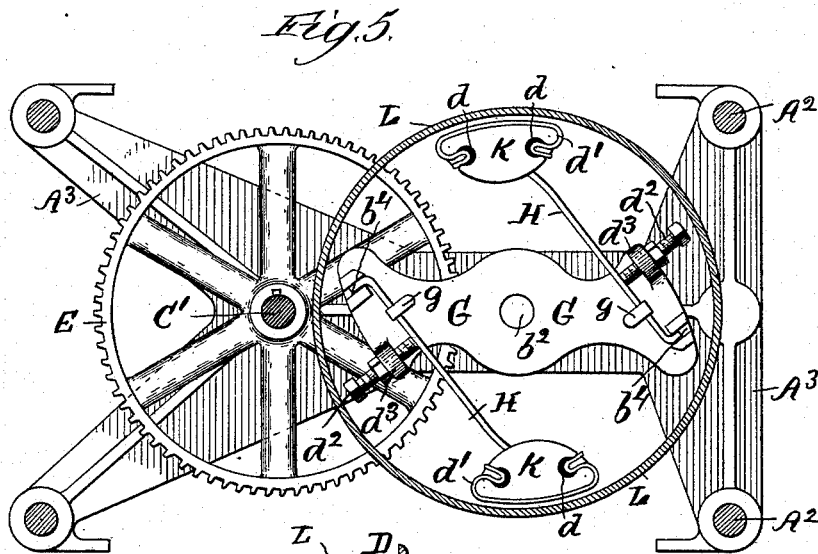
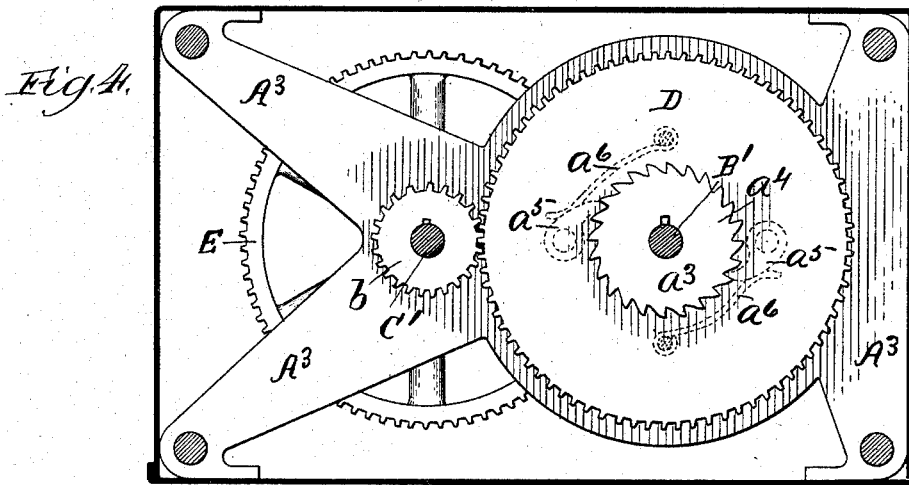

Witnesses:  
*Charles Hayward*  
*Clifford H. White*

Inventor:  
*S. R. Briggs.*  
 By *G. B. Coupland & Co.*  
*ATTORNEYS*

# UNITED STATES PATENT OFFICE.

SAMUEL R. BRIGGS, OF CHICAGO, ILLINOIS, ASSIGNOR TO THE CHICAGO AUTOMATIC FIRE-ESCAPE AND MANUFACTURING COMPANY, OF SAME PLACE.

## FIRE-ESCAPE.

SPECIFICATION forming part of Letters Patent No. 522,703, dated July 10, 1894.

Application filed December 17, 1892. Renewed May 9, 1894. Serial No. 510,665. (No model.)

*To all whom it may concern:*

Be it known that I, SAMUEL R. BRIGGS, a citizen of the United States, residing at Chicago, in the county of Cook and State of Illinois, have invented certain new and useful Improvements in Fire-Escapes, of which the following is a full, clear, and exact description, that will enable others to make and use the same, reference being had to the accompanying drawings, forming a part of this specification, in which—

Figure 1 is a plan; Fig. 2, a vertical longitudinal section on line 2, Fig. 1, looking in the direction indicated by the arrow; Fig. 3, a vertical longitudinal section on line 3, Fig. 1; Fig. 4, a vertical longitudinal section on line 4, Fig. 1; Fig. 5, a similar view on line 5, Fig. 1; and Fig. 6, a broken-away vertical transverse section on line 6, Fig. 3.

This invention relates to improvements in that class of fire-escapes wherein the operation of the device is automatically controlled, and the descent made perfectly safe without any attention from the person descending.

The supporting frame consists of the side-plates A A', the transverse rods A<sup>2</sup>, and the intermediate frame-plate A<sup>3</sup>.

The winding-drum, B, is loosely mounted on the shaft B' and has the rope B<sup>2</sup> wound thereon, as shown in Fig. 1. The shaft B' extends only part way across, (Fig. 6,) the outer end being journaled in the side frame-plate A, and the inner end in the intermediate plate A<sup>3</sup>. The curved guard, B<sup>3</sup>, is properly secured to the frame parts, (Fig. 2,) and extends part way around the drum, and serves the purpose of preventing the rope from being accidentally misplaced. The pinion a is rigidly mounted on the hub of the rope-drum, and engages with the gear-wheel, C, loosely mounted on the counter shaft C'; the respective ends of which are provided with suitable bearings in the two side-pieces of the frame. One end of the coiled spring C<sup>2</sup> is secured to the frame, as at a', the opposite end being secured to the hub 8 of the gear-wheel C. Now as the rope is unwound by a descending weight, motion is transmitted to the gear-wheel C by the engaging-pinion on the drum-

hub, and the spring is wound up, so that the stored power thereof serves to rotate the drum, B, in the opposite direction when the weight is discharged, and automatically rewind the rope and return the sling, C<sup>3</sup>, for another person or load.

The gear-wheel D is loosely mounted on the shaft B', and located close to the rope-drum on the opposite side from the pinion a. This side of the drum is provided with the annular chamber a<sup>2</sup>, (Fig. 6,) into which projects the hub a<sup>3</sup> of the gear-wheel, D, having teeth a<sup>4</sup> (Fig. 4.) forming a ratchet-wheel. The companion pawls, a<sup>5</sup>, (indicated in dotted lines Fig. 4.) are pivoted to the drum and engage with said ratchet-teeth, so that the gear-wheel D, its shaft and connecting parts remain stationary while the rope is being rewound. The springs a<sup>6</sup> serve to retain the pawls in an engaged position.

The gear-wheel D engages with the pinion b, rigidly mounted on the shaft C'. The gear-wheel E is also rigidly mounted on the shaft C', and in turn engages with the solid pinion F, having the stub-shafts b' b<sup>2</sup> formed integral. The axis of the pinion F is in the same plane with that of the rope-drum shaft.

It will be observed that the teeth of the pinion F (Fig. 6.) extend but about half way across the periphery, leaving the untoothed surface or hub part, b<sup>3</sup>, from which project two or more arms G, as shown in Figs. 1, 3 and 5. The outer ends of these arms are provided with the socket-parts b<sup>4</sup> (Fig. 5.) in which are inserted the bent inner ends of the spring brake-levers H. The brake-shoes K are mounted on the outer ends of the brake-arms, and are provided with recesses d in which are removably inserted the respective ends of the leather d'.

The wearing surface of the brake-shoe may be of leather or any other suitable material, and when too much worn to be of any further use can be easily replaced by a new part, as provided for.

The intermediate plate or part, A<sup>3</sup>, of the frame has the over-projecting brake-rim L (Figs. 1, 3, 5, and 6.) formed thereon; with the inner circumferential surface on which

the brake-shoes are adapted to have frictional contact for the purpose of retarding and regulating the action of the device.

5 The brake-shoes are held normally out of contact with the rim L by means of the adjusting screw-bolts  $d^2$ , inserted through the threaded lugs  $d^3$ , formed on the arms G and bearing against the spring brake-levers, as shown in Fig. 2. By this arrangement the  
10 maximum speed of the device may be increased or diminished, and regulated to a nicety.

15 The brake-shoes are brought in contact with the brake-rim by centrifugal force as a load is being carried down.

The stops  $g$  prevent the brake-levers from having a lateral movement, and thereby throwing the brake-shoes out of position with reference to their frictional surface.

20 The respective ends of the sling  $C^3$  are detachably secured to the link  $g'$  by snap-hooks  $g^2$   $g^3$ , as shown in Fig. 1. The link  $g'$  carries the stop  $h$ , and is connected to the end of the rope  $B^2$ . The rope runs between the friction-  
25 rollers  $h'$   $h^2$ , and the elastic cushion  $h^3$  on the rope receives the contact of the stop  $h$  and lessens the shock of the return movement so as to avoid injury to these parts. The sling will ordinarily consist of a wide band or strap  
30 to be passed around the body under the arms, but any other form of sling may be used, or a basket or chair seat.

The descent will be so governed and controlled by the centrifugal brake-mechanism  
35 that the speed will be about the same no matter what the weight of the load may be.

40 The device will be secured in a stationary position convenient to a window or other place of egress, and all that is required is for the person to be secured in the sling and swung out; the rope being instantly rewound and the sling returned when the same is relieved of the load carried down.

45 Having thus described my invention, what I claim as new, and desire to secure by Letters Patent, is—

1. In a fire escape, the winding drum loosely

mounted on its shaft and having a pinion, the countershaft having a loose pinion engaging the pinion of the drum, a retrieving spring  
50 connected to said loose pinion, a fast pinion on the countershaft engaging a pinion on the main shaft, which pinion has ratchet and pawl connection to the winding drum, and a  
55 fast pinion on the countershaft engaging a gear carrying spring brake arms, said arms having frictional contact with a fixed rim on the frame, all combined substantially as described.

2. In a fire escape, the frame having side  
60 plates and an intermediate plate provided with a friction band, the main shaft and its winding drum, and the gear in line with the main shaft and having arms provided with  
65 friction brake levers bearing on said friction band, and the countershaft and its gears engaging the gears of the drum and of the brake arms repeatedly, and the spring acting to  
70 wind said gears in one direction, all combined substantially as described.

3. In a fire escape, the frame and shafts supported thereby, the winding drum on one  
of said shafts and the train of gears engaging said drum and the brake arms, said arms  
75 mounted on a shaft in line with the drum shaft and carrying spring levers having brake shoes at their outer ends, and means for adjusting the pressure of said shoes on the brake  
80 rim which rim is fixed to the frame and surrounds the brake arms, all combined substantially as described.

4. In a fire escape, the winding drum, gears, and brake arms connected and relatively arranged substantially as described, the fixed  
85 brake rim, and the brake shoes mounted on spring levers, said levers entering sockets in the brake arms, and set screws extending from lugs on the arms and bearing against the spring levers to regulate the tension thereof, all combined substantially as described.

SAMUEL R. BRIGGS.

Witnesses:

L. M. FREEMAN,  
L. B. COUPLAND.