

(No Model.)

2 Sheets—Sheet 1.

N. PETERS & M. MATHEY.
MACHINE FOR PACKING BARREL HEADS, &c.

No. 524,729.

Patented Aug. 21, 1894.

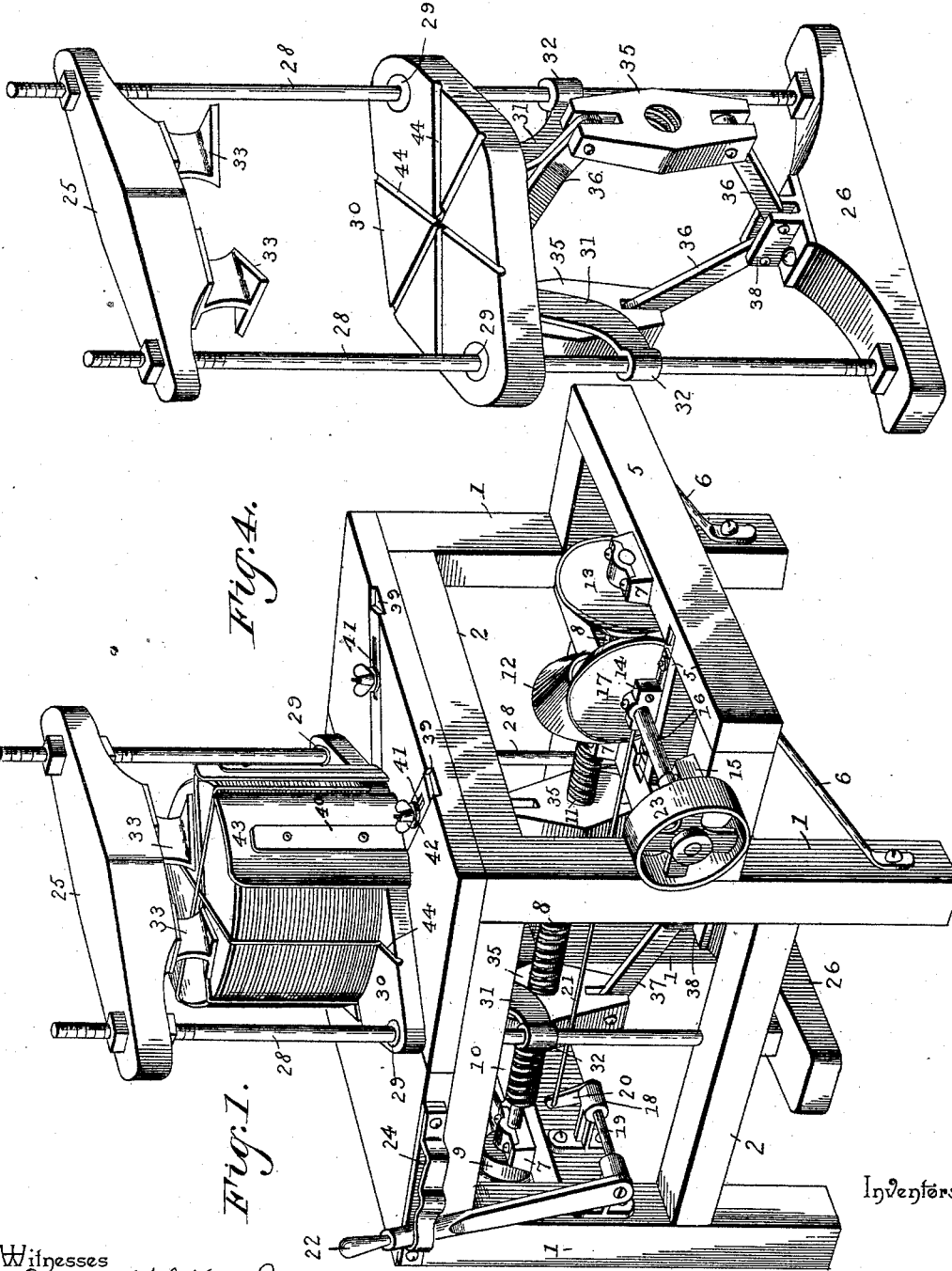

Fig. 4.

Fig. 1.

Inventors

Witnesses
Julius Ulke, Jr.
S. J. Riley

By Their Attorneys. *Newton Peters and Maurice Mathey*
Casnow & Co.

N. PETERS & M. MATHEY.

MACHINE FOR PACKING BARREL HEADS, &c.

No. 524,729.

Patented Aug. 21, 1894.

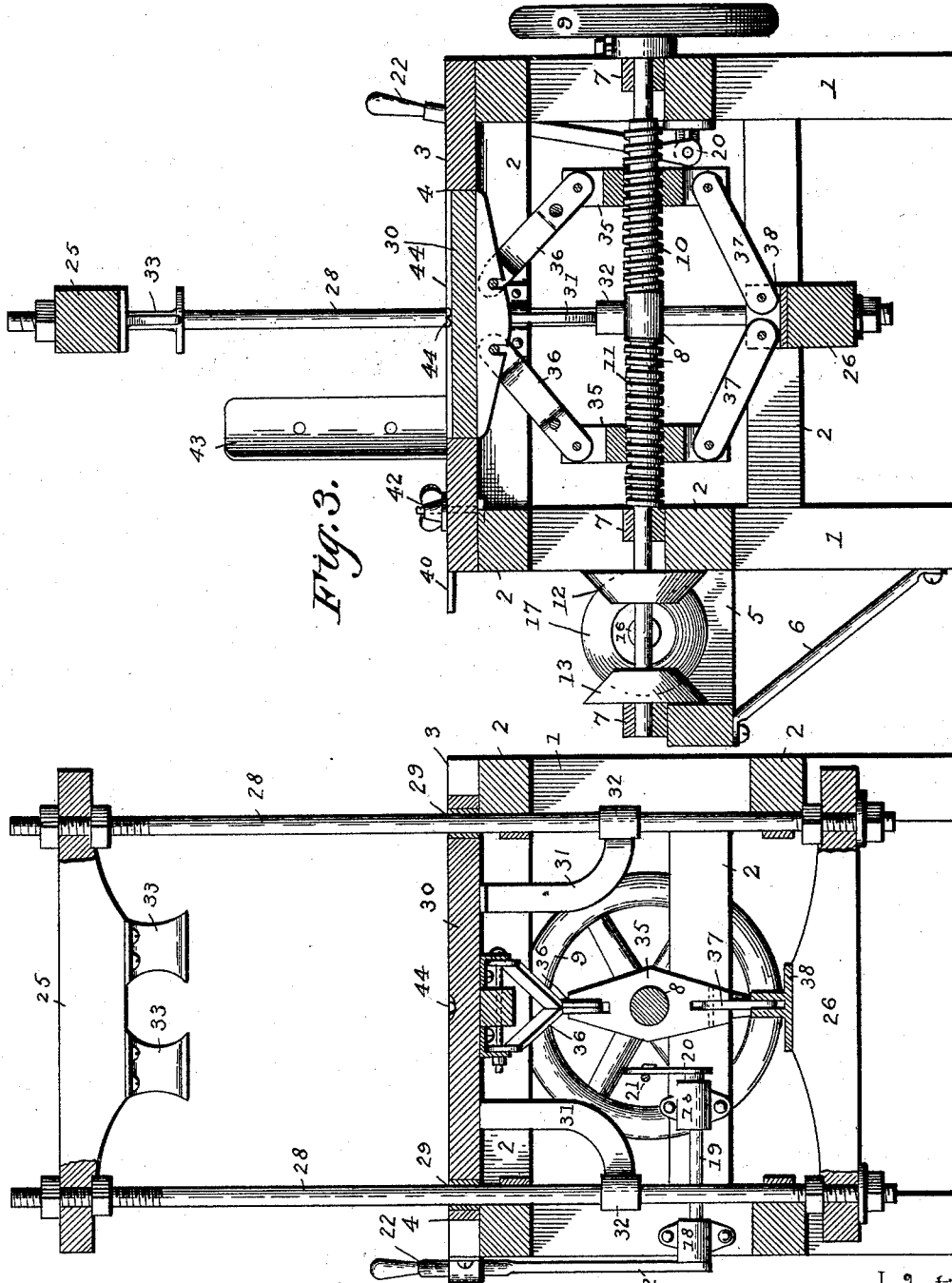

Fig. 3.

Fig. 2.

Witnesses

Julius Ulke
J. F. Riley

By their Attorneys.

Newton Peters and
Maurice Mathey,

Attorneys.

Inventors

UNITED STATES PATENT OFFICE.

NEWTON PETERS AND MAURICE MATHEY, OF MILWAUKEE, WISCONSIN.

MACHINE FOR PACKING BARREL-HEADS, &c.

SPECIFICATION forming part of Letters Patent No. 524,729, dated August 21, 1894.

Application filed March 23, 1894. Serial No. 504,840. (No model.)

To all whom it may concern:

Be it known that we, NEWTON PETERS and MAURICE MATHEY, citizens of the United States, residing at Milwaukee, in the county of Milwaukee and State of Wisconsin, have invented a new and useful Machine for Packing Barrel-Heads, &c., of which the following is a specification.

Our invention relates to improvements in machines for packing or baling barrel-heads and similar articles; the objects in view being to produce a machine of simple construction, strong and durable and which may be operated with but little power and with dispatch and which is capable of compressing a number of barrel heads or other similar articles into compact bales for the purpose of tying the same in convenient bundles or bales for shipment or storage.

Other objects and advantages of the invention will appear in the following description, and the novel features thereof will be particularly pointed out in the claims.

Referring to the drawings:—Figure 1 is a rear perspective view of a machine embodying our invention. Fig. 2 is a vertical transverse sectional view of the same. Fig. 3 is a vertical longitudinal sectional view thereof. Fig. 4 is a detail in perspective of the compressing yoke and its guide-rods.

Like numerals of reference indicate like parts in all the figures of the drawings.

In the construction of our machine we employ four stout posts 1 arranged in the form of a rectangle and connect them by upper and lower sills or bars 2, so as to produce a substantial frame. This frame we surmount by a table 3, the same being provided at its center with a diamond-shaped or other opening 4. At the rear end of the frame we locate a horizontal supplemental frame 5, the same being supported by suitable inclined braces 6. Located upon the outer cross-bar of the frame 5 and two of the adjacent sills which horizontally align therewith is a series of aligning bearings 7 and located therein and extending from front to rear of the machine is a main shaft 8. This main shaft 8 extends beyond the front of the machine and may have applied thereto a fly-wheel 9. This shaft 8 is at opposite sides of its center threaded in reverse directions so as to produce right

and left-hand screws 10 and 11, respectively. Between the two rear bearings 7 we locate upon the shaft a pair of cone-gears 12 and 13, the same having their cone-faces toward each other and spaced apart as shown. A sliding journal-box 14 is located on a suitable cross-bar of the frame 5 and opposite the same is pivotally mounted an aligning journal-box 15, and these journal-boxes accommodate a countershaft 16. This countershaft is provided at its outer end with a band-pulley 23, whereby it may be geared with the motor employed to operate the machine. The inner end of the shaft 16 is provided with a conical pulley 17 arranged at a right angle and between the pulleys 12 and 13.

At the front of the machine in transversely opposite bearings 18 we locate a transverse rock-shaft 19, whose inner end is provided with a rock-arm 20, that by means of a connecting-rod 21 is connected with the sliding-box 14 of the countershaft, whereby by a rocking of the shaft 19 through the medium of a hand-lever 22 arranged at the side of the machine and connected to said shaft the countershaft may be operated and thus the cone-gear carried thereby thrown into engagement with either of the pulleys 12 or 13, and hence the main shaft rotated in either direction. The lever 22 is within reach of the attendant who stands at the front of the machine and may be locked at three points by means of a locking-bar 24, so that the cone-pulley 17 may be moved into engagement with either of the pulleys 12 or 13 or be located between the same out of contact with either. When in the latter position of course the machine is inoperative and the countershaft runs idle. The fly-wheel may be omitted if desired or may be employed as a hand-wheel, in which case the countershaft, the band-pulley, the pulley 17, and the lever and devices for operating said countershaft would be omitted from the machine.

25 designates an upper transverse yoke or cross-head, and 26 a lower transverse yoke or cross-head, the said yokes being located respectively above and below the table 3, and are connected by vertical tie-rods 28 which pass through the diamond-shaped opening 4 at the extremities thereof. These vertical tie-rods pass loosely through perforations 29

formed in a diamond-shaped plate 30. To the under side of the plate are connected outwardly disposed curved braces 31 which terminate in eyes 32 vertically aligning with the perforations 29 and through which also in a loose manner pass the tie-rods.

To the under side of the upper yoke-bar 25 are bolted depending triangular shaped castings or feet 33, which have their acute angles disposed toward each other. The lower ends of the tie-rods 28 are secured to the lower yoke 26 in a rigid manner.

Upon the right and left-hand threads of the main-shaft we locate similarly threaded nuts 35, the ends of the nuts being slotted above and below the shaft and connected pivotally to links 36 whose upper ends are pivoted to the under side of the plate 30, and their lower ends pivotally connected to links 37, whose lower ends are connected pivotally to the casting 38 upon the upper side of the center of the lower yoke 26.

Upon the table 3 in rear of the plate 30 radial grooves 39 are formed and adjustably arranged in the grooves are L-shaped standards 40, the lower portions of which are slotted at 41 to receive a thumb-screw 42, whereby said standards may be adjusted independent of each other to and from the plate 30. The vertical portions of these standards are provided with curved gage-plates 43 which conform to the edges of the plate 30 and are adjustable by the movability of the standards as described, so that they may be set at proper distances from the plate 30.

The plate 30 it will be observed is provided with one or more grooves 44 intersecting and formed at the upper side thereof so that baling-wires, cords, or bands may be passed under the articles supported by the plate 30 for the purpose of tying up the bale. The tapering feet 33 are disposed opposite the spaces between the grooves.

Assuming that the band-pulley of the countershaft is connected with a proper motive-power the machine is ready for operation. The lever 22 is first manipulated so as to lower the plate 30 and elevate the upper yoke, which is accomplished by moving the lever 22 so that the rear pulley 13 is in engagement with the pulley of the countershaft. This causes the main shaft to rotate, drawing the nuts 35 together. The standards or gages are next set so as to form a convenient back wall against which the barrel heads or other articles may be rapidly piled and yet be in proper position to receive the pressure. Having piled a sufficient number of barrel heads upon the plate 30 the lever 22 is now reversed so as to give the main shaft a reverse rotation and cause the nuts to be brought together. This movement of the nuts toward each other causes the plate 30 to be forced upward by means of the links 36 and the lower yoke 26 to be forced downward by means of the links 37, so that as a consequence the castings in the upper transverse yoke are drawn down-

ward in contradistinction to the upward movement of the plate 30 and thus the barrel heads or other articles arranged therebetween are securely clamped or compressed and while in this condition the bale-bands or other ties are applied; the lever is now manipulated, as in the first instance and the parts return to their normal positions, after which the baled barrel-heads are removed, a new lot substituted, and the operation repeated.

It will be observed that our machine is of very simple construction, is under thorough control of the operator, and will efficiently bale barrel heads or other articles of a similar nature in a rapid and convenient manner.

We do not limit our invention to the precise details of construction herein shown and described, but hold that we may vary the same to any degree and extent within the knowledge of the skilled mechanic.

Having described our invention, what we claim is—

1. In a machine of the class described, the combination with a framework having a table provided with an opening, gage-devices arranged at one side of the opening, a plate having vertical guides arranged in the opening in front of the gage-devices, and a reversely threaded shaft arranged below the plate, of means for rotating the shaft in either direction, nuts arranged upon the shaft, upper and lower yoke-bars above and below the plate and shaft, the tie-rods connecting the yoke-bars and passing through the vertical guides of the plate, and pivotal links between the upper and lower sides of the nuts, the lower-yoke-bar, and the plate, substantially as specified.

2. In a machine of the class described, the combination with the framework having the table provided with the diamond-shaped opening, the radial grooves in rear of the opening, the L-shaped standards arranged in the grooves and having slots, the gage-plates carried by the standards, and the adjusting-screws passed through the slots of the standards, of the lower reversely threaded shaft, means for operating the same in either direction, nuts arranged upon the threads of the shaft, the plate arranged in the opening of the table and having vertical guides at its ends, the upper and lower yoke-bars, the intermediate vertical connecting-rods passing through the guides of the plate, and the links between the nuts and lower yoke-bar and between the nuts and the plate, substantially as specified.

3. In a machine of the class described, the combination with the main frame having the rectangular framework having the rear extension with aligning bearings the main shaft arranged in the bearings and having right and left hand threads and in rear of the same the opposing conical gears, the countershaft arranged at a right angle to the main shaft, a pivotal journal-box for the outer end of the

same, and a sliding journal-box for the inner
 end thereof, the belt-pulley on the outer end
 of the countershaft, the intermediate cone-
 gear on the inner end thereof, the rock-shaft
 5 arranged in horizontal bearings, the lever for
 the outer end of the same, means for locking
 the lever, the rock-arm at the inner end of
 the shaft, a connecting-rod between the same
 and the sliding journal-box of the counter-
 10 shaft, of the opposite nuts arranged on the
 threads of the main shaft, the superimposed
 plate having the vertical guides, the tie-rods
 extending through the guides, the upper and
 lower yoke-bars, and the pivotal links between
 15 the lower sides of the nuts and the lower yoke-
 bar and between the upper sides of the nuts
 and the plate, substantially as specified.

4. In a machine of the class described, the
 combination with a framework provided with
 20 a table and having an opening therein, of up-
 per and lower cross-heads connected together,
 a plate interposed between the cross-heads
 and arranged in the opening of the table, the
 opposite toggle connections between the plate
 25 and the lower cross-head provided with oppo-
 sitely threaded openings, a shaft having right
 and left hand threaded portions engaging the

reversely threaded openings of the toggle con-
 nections, and an adjustable guide or gage
 30 mounted on the table, and arranged adjacent
 to the opening thereof, substantially as de-
 scribed.

5. In a machine of the class described, the
 combination of a framework, upper and lower
 cross-heads, vertical parallel rods connecting
 35 the cross-heads, a plate interposed between
 the cross-heads and mounted on and guided
 by said rods, the opposite toggle connections
 between the plate and the lower cross-head
 provided with the oppositely threaded open-
 40 ings, a horizontal shaft having right and left
 hand threaded portions engaging the oppo-
 sitely threaded openings of the toggle con-
 nections, and a gage mounted on the frame-
 work, substantially as described. 45

In testimony that we claim the foregoing as
 our own we have hereto affixed our signatures
 in the presence of two witnesses.

NEWTON PETERS.
 MAURICE MATHEY.

Witnesses:

ARTHUR WEHE,
 RICHARD WEHE.