

J. WARDALL.
CIRCULAR KNITTING MACHINE.

(No Model.)

(Application filed Jan. 23, 1899.)

2 Sheets—Sheet 1.

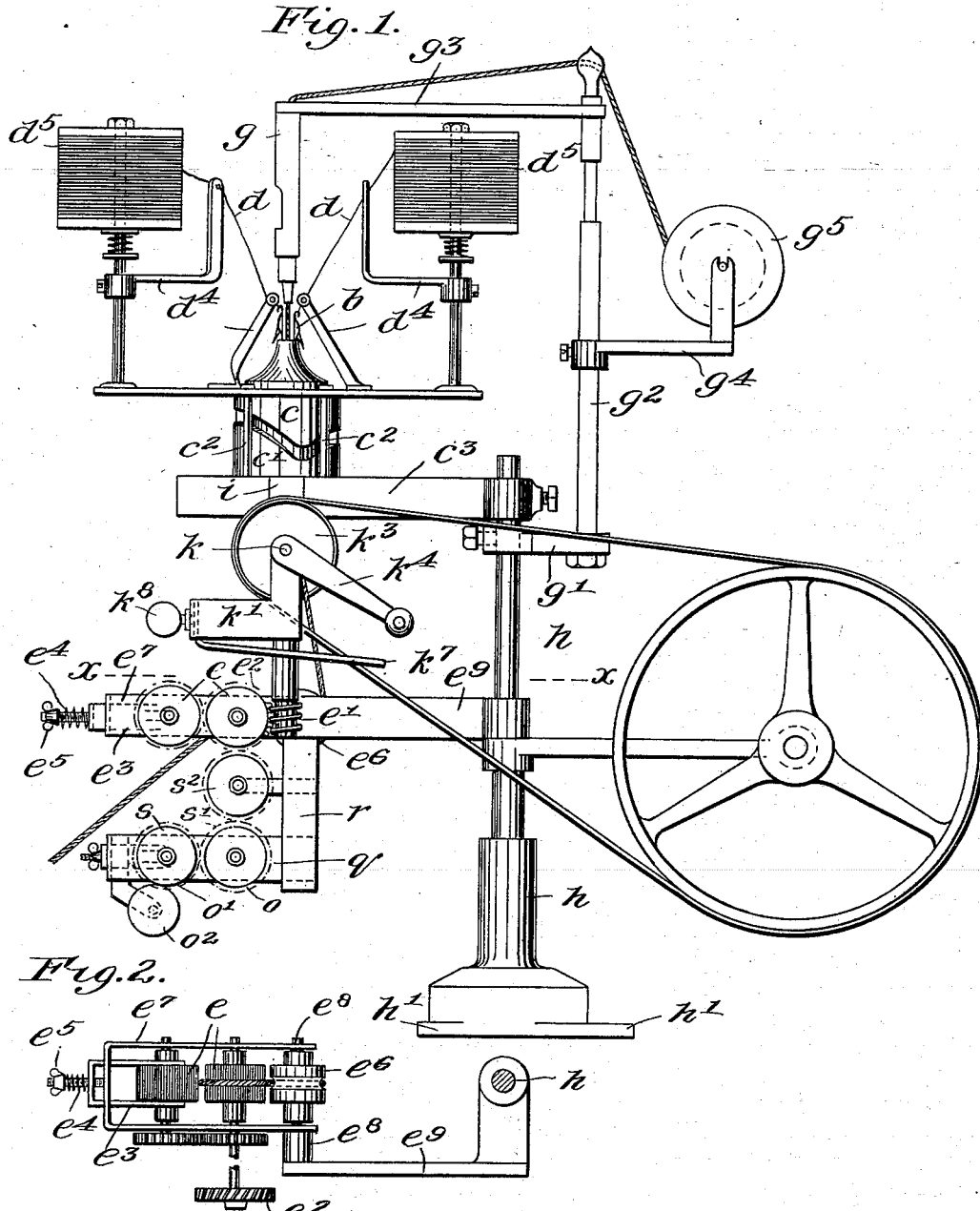

Witnesses:
C. D. Kesler
W. Lee Helms.

Inventor
James Wardall
 By *James L. Norris*
Atty

J. WARDALL.
CIRCULAR KNITTING MACHINE.

(Application filed Jan. 23, 1899.)

(No Model.)

2 Sheets—Sheet 2.

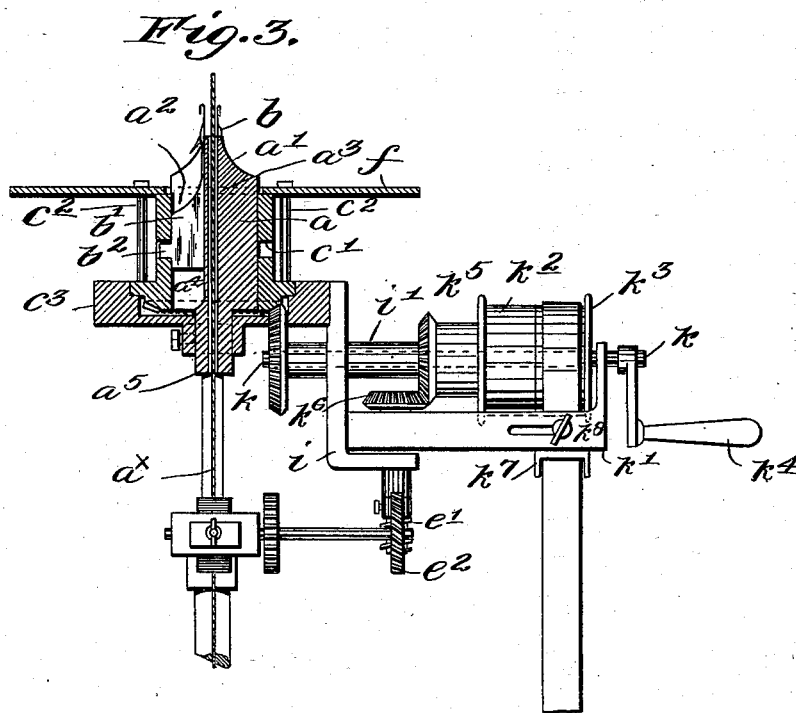

Witnesses
C. D. Heiler
W. Lee Helms.

Inventor
James Wardall
By James L. Norris
Atty.

UNITED STATES PATENT OFFICE.

JAMES WARDALL, OF NOTTINGHAM, ENGLAND, ASSIGNOR TO CHARLES MARTIN, OF SAME PLACE.

CIRCULAR-KNITTING MACHINE.

SPECIFICATION forming part of Letters Patent No. 648,347, dated April 24, 1900.

Application filed January 23, 1899. Serial No. 703,118. (No model.)

To all whom it may concern:

Be it known that I, JAMES WARDALL, hosiery manufacturer, a subject of the Queen of Great Britain and Ireland, and a resident of Hucknall Torkard, Nottingham, England, have invented certain new and useful Improvements in Knitting-Machines for Producing Laces, Cords, and Like Articles, of which the following is a full, clear, and exact specification.

This invention relates to machines for producing by knitting fancy tubular or covered cords, such as blind-cords, picture-cords, cords for upholstery purposes, stay or boot laces, tapes, and the like. Such articles have up to the present been usually made by braiding or plaiting machines, the latter being capable of working at a much higher speed than knitting-machines hitherto constructed for the same purpose.

The main object of the present invention is to construct a knitting-machine which will work reliably not only at as high but even at a very much higher speed than the braiding or plaiting machines and which is capable of producing the great variety of patterns distinctive of knitted goods.

In a machine made according to my invention each knitting-needle has in the usual way a projection or butt which engages in a groove or slot in a hollow cylinder, hereinafter called the "cam-ring," so that when the cam-ring rotates relative to the needle, or vice versa, the needle is caused to move alternately in either direction parallel to the axis of the cam-ring, and thereby perform the knitting process. The number of reciprocations of the needle during one rotation of the cam-ring will obviously only depend upon the path of the groove.

Now I have found that in order to obtain the necessary travel of the needles at a sufficiently-high speed the diameter of the path or groove in which the needle projections or butts travel must be considerably larger than the diameter of the circle in which the needle-points are arranged when small articles, such as laces or the like, are to be produced, so that the inclines or rises in the cam-ring of the machine are sufficiently moderate to suit the high speed of working.

As a result of my experiments I have found that the steepness of the cam-groove is governed by the velocity of the needle-butt in the groove—that is to say, the greater the velocity of the needle-butt the less the steepness of the cam-groove. The velocity of the needle-butt depends upon the extent of rise of each needle and the number of loops it has to knit per minute. In a machine constructed according to my invention it is therefore possible to obtain the highest speeds of working consistent with the safety of the other moving parts of the machine.

In order that the needles should travel with the greatest possible smoothness, they should be of such a shape as to enable substantially the whole of both their inner and outer edges to be positively guided throughout the travel of the needles.

Suitable devices are provided for maintaining the proper tension on the yarns and on the work, the tension on the work being obtained by means of a take-up arrangement which can be adjusted to correspond with the speed of working.

In order that my invention may be readily understood, I will describe the same with reference to the accompanying drawings, in one form of which the inclines on the cam-grooves when developed on a flat surface are practically straight lines, although it is obvious that they might be more or less in the form of curves.

Figure 1 is a side elevation of one form of my improved machine. Fig. 2 is a horizontal section on the line xx , Fig. 1. Fig. 3 is a detail view of the needle-cylinder and its driving mechanism, the former being in vertical central section.

a is the needle-cylinder, the upper part a' of which is contracted, as shown. a^2 are vertical tricks in the said cylinder, and a^3 is a narrow central aperture or bore down which the work a^x passes.

b represents the needles, of which the number may be varied according to circumstances. The said needles are secured in line with the inner edges of their jacks b' , while the needle-butts b^2 project from the outer edges thereof. Thus the butts are disposed on a comparatively-large circuit, while the needles are ar-

ranged on a working circle of very small diameter.

c is the cam-ring, which is made of steel, as are also the needle jacks or sinkers. This cam-ring closely surrounds the needle-cylinder and has its groove c' arranged at suitable angles proportionate to the speed at which the needle-butts are intended to travel. Thus for a speed of about eight hundred to one thousand revolutions per minute in a machine having four rises per revolution and with a rise and fall of the needles amounting to five-eighths of an inch the angle of inclination of the cam-groove at any point with a line through the point parallel to and in the same plane as the axis of the cam-ring should not be less than forty degrees. For speeds of from five hundred to seven hundred revolutions the angle should not be less than thirty-five degrees, while for speeds of two hundred to four hundred revolutions it should not be less than thirty degrees.

The minimum diameter of the cam-cylinder depends upon the rise or length of travel of the needles and the number of rises in the cam-groove, there being one rise for each of the knitting-yarns employed. For a machine to work at eight hundred to one thousand revolutions a convenient internal diameter is approximately thirty-one thirty-seconds of an inch if two rises be employed, but if there be three it should be one and seven-sixteenths of an inch, as in the drawings, while for four it should be one and fifteen-sixteenths of an inch, the circle on which the needles work being one-eighth-inch diameter in each case. If, however, the speed be, say, from two hundred to four hundred revolutions, the diameters might be nineteen thirty-seconds of an inch with two rises, fifty-nine sixty-fourths with three, and one and seven thirty-seconds with four. These proportions give substantially the minimum diameters of the cam-ring in the cases stated; but it is obvious that larger diameters may be used, as the inclines would then be within the limit of steepness. The positive guiding of the needles is due to their jacks b' conforming to the shape of the tricks a^2 and being guided on their inner edges by the inner walls a^4 of the latter, while their outer edges are guided by the cam-ring. As both edges are parallel, the true longitudinal movement of the needles is effectually insured.

d represents the knitting-yarns (which may be of various colors) for the tube or covering. The work a^x as produced is drawn down through the cylinder-bore a^3 by a pair of roughened take-up rollers e , which are in gear by a worm e' and pinion e^3 with the driving mechanism of the cam-ring, so that their speed corresponds always to the rate at which the machine is working. The pressure or grip between the rollers is obtained by a fork e^3 , which is pressed against the axle of the outer roller by a spring e^4 , adjustable by a wing-nut e^5 . A guide-roller e^6 is provided

under which the work passes on its way to the take-up rollers, thus insuring its being kept central thereon. This take-up arrangement is mounted in a frame e^7 , carried by a spindle e^8 , projecting from a bracket e^9 .

The cam-ring consists of an upper and lower portion, which are completely separated by the cam-groove, the mechanical connection being effected externally by short pillars or uprights c^2 . The bracket c^3 has secured centrally in it a downwardly-extending stem or shank a^5 on the needle-cylinder, whereby the latter is fixed in position and can be adjusted as to height to vary the length of the loops. Upon the cam-ring is secured a plate or table f , carrying the guides or feeders d^4 and spools or cops d^5 for the knitting-yarns.

If a central core or filling-yarn be employed, it is supplied from a spool or spools arranged in any convenient position near the machine.

The machine shown has a central stem or pedestal h , adapted to be screwed to a bench or table through lugs h' . On this pedestal are mounted the bracket e^3 , carrying the knitting mechanism proper, the bracket e^9 , supporting the take-up mechanism, and also a bracket g' , supporting a pillow g^2 , from which project arms g^3 g^4 , the former carrying the feed-tube g and the latter the spool g^5 , on which the core is wound. To the side of the bracket c^3 is secured another bracket i , supporting the driving mechanism, the spindle k of which passes through the bracket i and a sleeve i' thereon and is supported at its outer end by a frame k' , carried on said bracket. On the spindle k are arranged the fast and loose driving-pulleys k^2 k^3 , a handle k^4 for working the machine slowly when adjusting the parts, and a bevel-wheel k^5 for driving the worm e' , whose spindle has at its upper end a bevel-wheel k^6 , meshing with the said wheel k^5 .

k^7 is a fork for shifting the driving-belt, and k^8 is a set-screw for clamping the said fork in place.

If the cam-ring is stationary and the needle-cylinder revolves, it is necessary to provide means for taking the twist out of the core.

Referring to the pattern-printing arrangement, this is intended more especially for printing patterns on goods consisting of plain yarns all of the same color, which goods would otherwise be devoid of pattern. The said arrangement comprises a pair of printing-rollers o o' , the latter of which is engraved in any desired way and is kept "inked" by a color-wheel o^2 . Suitable means are provided to press the roller o' against the roller o , and said rollers are mounted in a frame q , substantially similar to the frame e^7 of the take-up arrangement. This frame q is secured to the machine by a vertical arm r . The printing-rollers are driven by gear-wheels s s' s^2 , the last of which gears with a corresponding gear-wheel on the axle of one of the take-up rollers, and the work as it leaves the take-up arrangement passes down directly between

the printing-rollers *o o'*, and thus has the desired pattern printed upon it.

Although I have described in detail one form of my invention, I wish it to be understood that I do not confine myself to the exact construction and arrangement of the parts shown in the drawings.

What I claim is—

1. In a high-speed knitting-machine for very small work in which one set of needles only is employed, the combination of a straight needle-cylinder with deep grooves, needles working parallel with each other and with the cylinder-axis, jacks for said needles of the same shape as said grooves, a straight cam-cylinder closely surrounding said cylinder and having its inner surface parallel with the axis of said needle-cylinder and serving as a guide for said needle-jacks and means for rotating one of said cylinders relatively to the other, substantially as described.

2. In a high-speed knitting-machine for very small work in which one set of needles only is employed, the combination of a needle-cylinder having deep vertical tricks or grooves, needles working parallel with each other, jacks for said needles of the same width as the tricks and having their edges parallel with the cylinder-axis, a cam-cylinder surrounding said needle-cylinder, a horizontal plate or platform secured to said cylinder, spool-spindles on said plate or platform, up-

per yarn-guides carried on said spindles, and lower yarn-guides arranged in close proximity to the needles, substantially as described. 35

3. A high-speed knitting-machine employing a single set of needles only, consisting of a straight needle-cylinder having deep grooves, a set of needles arranged parallel with one another and with the axis of the needle-cylinder, the needle-jacks formed of the same shape as said grooves, the straight cam-cylinder surrounding the needle-cylinder and having an internal surface parallel with the axis of the needle-cylinder and guiding said jacks, means for rotating one of said cylinders, a horizontal spindle-supporting plate mounted on the cam-cylinder and through which the needles work, the vertical spool-carrying spindles rising from said plate, the tension-springs mounted on said spindles and acting against the spools on the spindles, a tubular core-guide above the needles, tension devices mounted on the spindle-carrying plate, and needle-operating mechanism, substantially as described. 50 55

In witness whereof I have hereunto signed my name in the presence of two subscribing witnesses.

JAMES WARDALL.

Witnesses:

C. D. HEARN, Jr.,
THOS. H. COOK.