

C. C. GALE & G. F. DAVID.
Seal-Lock.

No. 161,023

Patented March 23, 1875.

Fig. 1

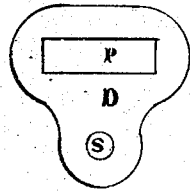
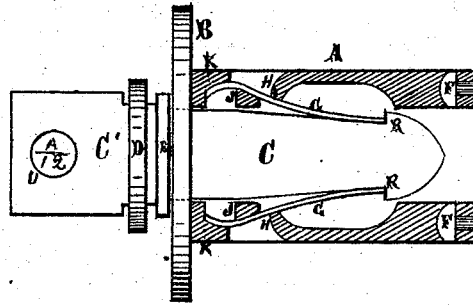

Fig. 3

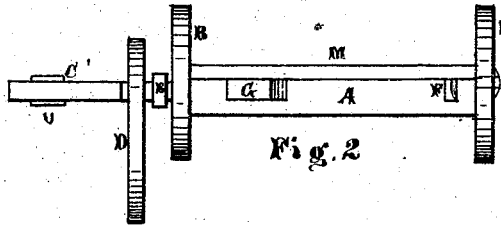

Fig. 2

Fig. 4

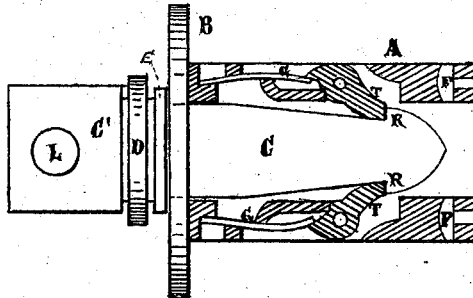

Fig. 5

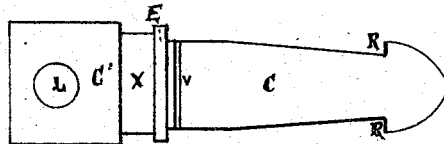

Fig. 6



Witnesses:
Israel Hogeland
Louis le Wallen

Inventors:
C. C. Gale
G. F. David

UNITED STATES PATENT OFFICE.

CHARLES C. GALE AND GEORGE F. DAVID, OF INDIANAPOLIS, IND.

IMPROVEMENT IN SEAL-LOCKS.

Specification forming part of Letters Patent No. **161,023**, dated March 23, 1875; application filed December 19, 1874.

To all whom it may concern:

Be it known that we, CHARLES C. GALE and GEORGE F. DAVID, of Indianapolis, county of Marion and State of Indiana, have invented an Improved Car-Seal, of which the following is a specification:

The object of our invention is to construct a car-seal in such a manner that when the car is locked the seal-key is very conspicuous, and can readily be seen as a car passes any given place, and will show if the car has been tampered with. The key cannot be removed from the lock unless it is broken.

Figure 1 represents a plan of our improved car-seal with the cover removed, to show the arrangement of the interior of the lock. Fig. 2 is a side view of the same with the cover on. Fig. 3 represents the cap or guard that slips on the key, and is secured to the car by a chain. Fig. 4 represents a different mode of fastening the key from that of Fig. 1. Figs. 5 and 6 represent a plan and side view of the key.

A represents the case, made of cast-iron, with the face-plate B cast thereon. Through the plate B is a hole, cored to receive the body of the key C. This key is formed as shown in Figs. 5 and 6, and has barbs or stops R R near the end. It also has a flange, E, cast around the body of the key, near the center, for the purpose of closing up the openings around the body of the key when inserted in the case. At one side of the flange E is a groove, V, cut across the face of the key C, for the purpose of weakening the key at this point, so that when the key is struck on the projection C' it will break at V. Between the flange E and the projection C' is a space, X, left for the reception of the cap or guard D. In the projection C' is a hole, L, made to receive a lead seal, U, to be used in combination with the key C, and to bear upon its face any device which parties may wish to imprint thereon, as shown in Figs. 1 and 2. The case A has several lugs, H J K, cast thereon, for the purpose of holding the springs G G in their proper position to clamp against the sides of the key C, as shown in Fig. 1; or there may be pawls used, as represented in Fig. 4, the object being to hold the key C so that it cannot be drawn out of the case A after being inserted. F F represent grooves cast in the case A to receive rivets, for the purpose of riveting the face-plate N of the cover M to the case A after the whole has been inserted in

the door or door-post of a car, as shown in Figs. 1 and 2.

The case A is inserted into the mortise of the door or post from the outside. The rivets are then placed in the receptacles formed in the end of the case A, after which the cover M is inserted in the mortise until the rivets pass through the holes in the face-plate N of the cover, and are there riveted fast to the case A, thus securing the lock firmly in the mortise, where it cannot be removed without cutting off the rivets or breaking the lock.

The cap or guard D is attached to the key C, for the purpose of preventing any person from tampering with the inside of the lock by wires or strips of steel; and also makes the key very conspicuous, so that any person whose duty it is to see that the cars are all right can readily detect anything wrong, because if the key is broken the guard D must fall, and show that the car has been tampered with.

The operation of our improved car-seal is as follows: When the car is required to be sealed the key C, with the cover or guard D placed thereon, is inserted in the lock-case A; and as the key is pressed in, the rounded end of the key presses the springs G G apart (or pawls T T) until the barbs R R have passed the ends of the springs or pawls, when they snap up against the body of the key, as represented in Figs. 1 and 4, and the key is held firm, and cannot be removed except by breaking the key at the groove V.

The projection C' has a hole, in which is inserted a lead seal for greater safety.

What we claim as new, and wish to secure by Letters Patent, is—

1. The case A, constructed and secured to the door as described, in combination with the key C, springs G G or pawls T T, and guard or cap D, substantially as specified.

2. The key C, constructed with barbs R R, flange E, breaking-groove V, projection C', and space X for the guard or cap D, substantially as specified.

In testimony whereof we have signed our names to this specification in the presence of two subscribing witnesses.

CHARLES C. GALE.
GEO. F. DAVID.

Witnesses:

ISRAEL HOGELAND,
LEWIS C. WALTER.