

G. M. GITHENS.  
Valve for Engines.

No. 161,025

Patented March 23, 1875.

Fig. 1.

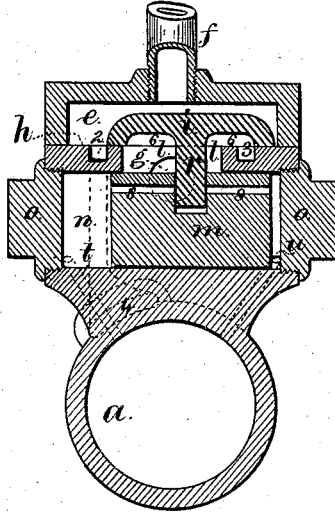

Fig. 2.

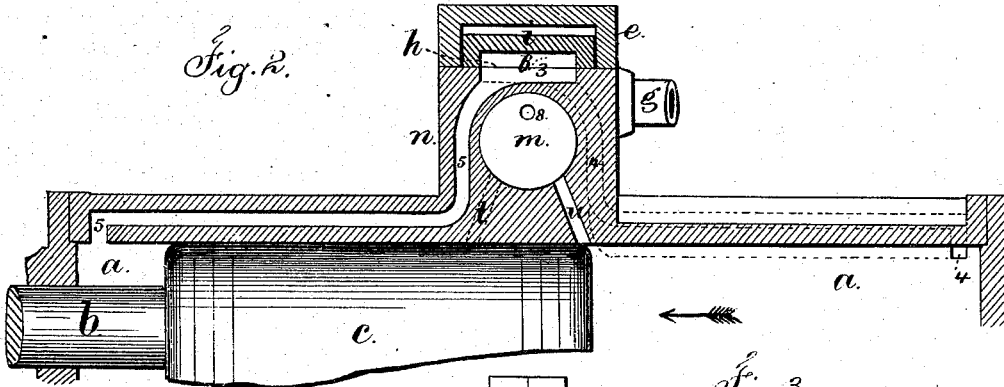
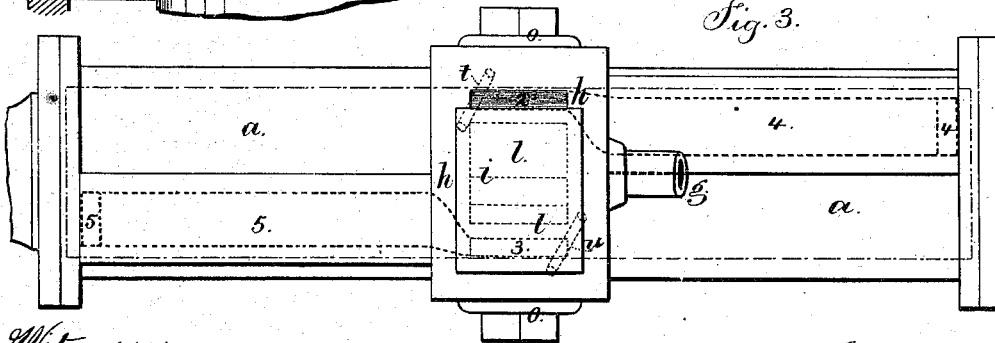

Fig. 3.



Witnesses

Chas H Smith  
Geo. P. Pinckney

Inventor  
George M. Githens  
By L. W. Sewell atty

# UNITED STATES PATENT OFFICE

GEORGE M. GITHENS, OF NEW YORK, N. Y.

## IMPROVEMENT IN VALVES FOR ENGINES.

Specification forming part of Letters Patent No. 161,025, dated March 23, 1875; application filed August 29, 1874.

*To all whom it may concern:*

Be it known that I, GEORGE M. GITHENS, of the city and State of New York, have invented an Improvement in Valves for Engines, of which the following is a specification:

Valves for engines have been moved for the admission of steam into a cylinder to act upon a piston that is connected with the valve. In such cases the steam has usually been admitted from the steam-chest, and it has been necessary to cushion the piston to prevent the thumping action of the valve-moving piston against the head of its cylinder.

My invention relates to a valve-moving device that is especially available in rock-drilling and other machinery where a long steam-piston can be made use of.

I employ the steam in the cylinder to move the valve, instead of taking it from the steam-chest, and the parts are constructed so that, as the steam-piston approaches the termination of its stroke in one direction, the packing of the piston uncovers a hole that leads to the valve-moving cylinder, where the steam passes to, and acts upon, a piston, moving that and the valve, and cutting off the steam from one side of the main cylinder and introducing it at the other side, and the piston, hence, is moved the other way until it uncovers another opening, allowing steam from the cylinder to pass to the valve-moving piston and throw it and the valve the other way. The parts are so arranged that there is no possibility of leakage from the steam-chest into the cylinder that moves the valve.

In the drawing, Figure 1 is a cross-section of the cylinder, valve, and valve-moving piston. Fig. 2 is a longitudinal section, and Fig. 3 is a plan, with the cover of the steam-chest removed.

The steam-cylinder *a*, piston-rod *b*, and piston *c* are of any desired size and construction, except that the piston is of sufficient length to effect the object hereafter named, and it is provided with double sets of packing-rings near the ends. The steam is admitted to the chest *e* by the pipe *f*, and the exhaust *g* passes in below the valve-seat *h*. The valve *i* acts in the usual way to admit steam to either port 2 or 3, to pass along the ports 4 and 5 to the

ends of the cylinder *a*, and the exhaust returns through the same channel to the cavity 6 of the valve *i*, and to the exhaust-port *l* and pipe *g*. The valve-moving piston *m* is in the cylinder *n*, that is placed below the valve-seat and between that and the main cylinder *a*, and it is provided with removable heads *o o*, and this piston *m* is connected by the stem *r* with the valve *i*, which stem passes through the exhaust, and there are ports or openings *t u* from the cylinder *n* to the cylinder *a*.

When the piston *c* is moving in the direction shown by the arrow, Fig. 2, it uncovers the port *u*, and the steam-pressure rushes into the cylinder *n* and drives the piston *m* into the opposite position to that shown, and moves the valve *i* with it, so as to open the port 2 to the eduction-port 6 and allow the steam to pass away, and at the same instant the steam is admitted, by the valve *i*, to the steam-cylinder *a*, through the port 3, to the other side of its piston, and the piston *c* is moved the other way, and near the end of this movement the piston opens the port *t*, and the steam, rushing from the cylinder *a* into the cylinder *n*, moves the piston *m* and valve *i* back to the former position, to readmit steam at the other side of the piston. The valve *i* and its piston *m* may be on the top of the cylinder *n*, or at one side, and the cylinder *n* may stand longitudinally or transversely to the cylinder *a*.

I make use of a hole, *s*, running from one end of the piston *m* to the other, and this serves as an escape for any steam that may remain in the cylinder *n* after the piston *m* has been moved, because this hole opens into the transverse groove in the piston *m*, into which the stem *r* of the valve enters, and this stem does not fit the groove tightly, but it acts to close that portion of the hole leading to the side that the steam is pressing upon, because the piston is in contact with the stem at this side, while the other portion of the hole is open to the exhaust, so that there will be no hinderance to the movement of the piston *m* from any steam remaining in the cylinder.

Efforts have been made to admit steam from the main cylinder to the valve-moving cylinder; but the valve was between them, and the connection from the valve to the piston was through the steam-space, and hence the valve-

moving piston was exposed to pressure from the steam in the steam-chest, and there was risk of leakage, obstructing the movement of the valve-piston. By placing the valve-moving piston below the valve, or between it and the steam-cylinder, the valve-moving cylinder is open to the exhaust, and pressure can never accumulate in the same.

I claim as my invention—

1. The valve-moving piston and a stem passing through the exhaust-port, in combination with the steam-valve and the main cylinder, piston, and ports, the valve-moving piston being located between the steam-valve and the main cylinder, for the purposes and substantially as specified.

2. The valve-moving piston, having openings from each end to transverse groove receiving the valve-stem, in combination with the steam-valve, ports, main cylinder, and piston, substantially as specified, whereby the steam-spaces of the valve-moving piston are opened to the exhaust, as set forth.

Signed by me this 26th day of August, A. D. 1874.

GEORGE M. GITHENS.

Witnesses:

GEO. T. PINCKNEY,  
HAROLD SERRELL.