

J. N. SMITH.
Railway-Axle Box.

No. 161,069

Patented March 23, 1875.

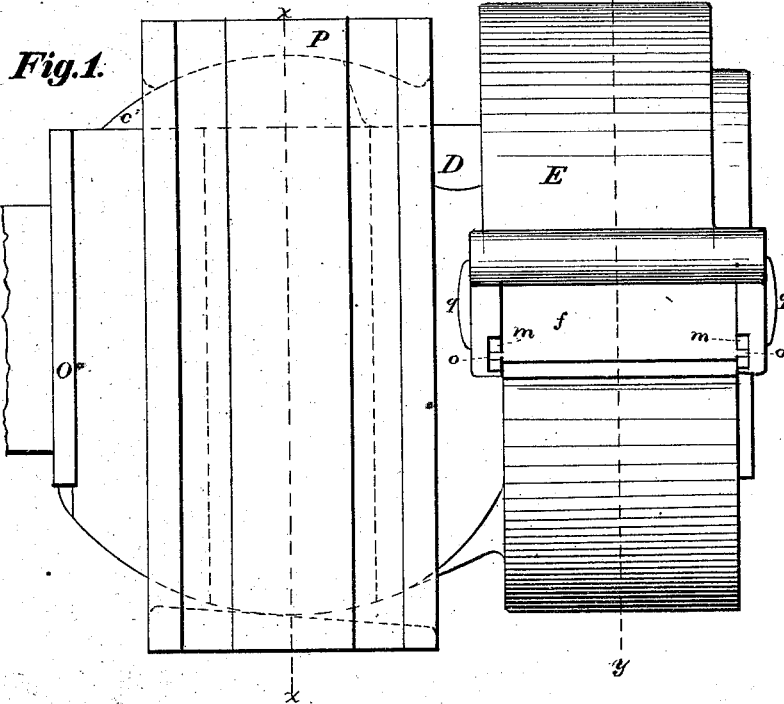
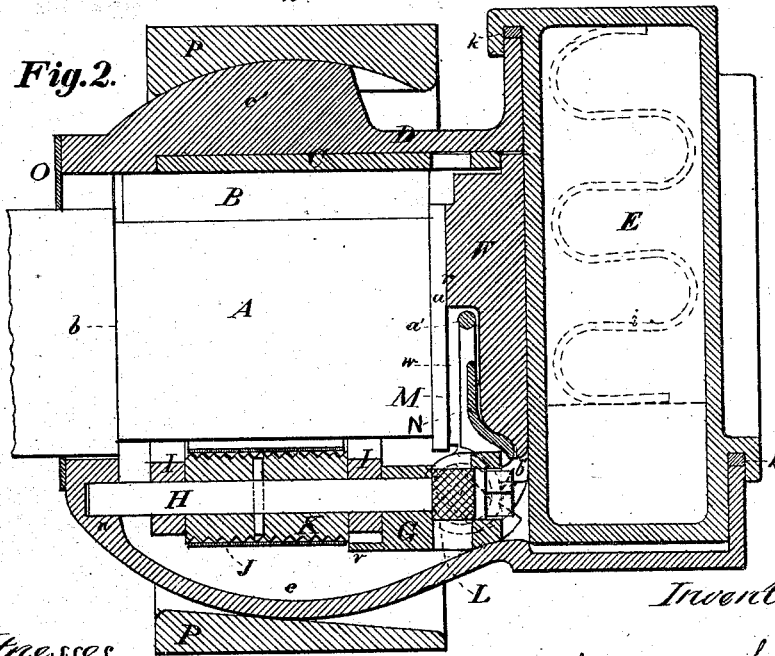

Fig. 2.



Witnesses

W. L. Rowe

Inventor

J. Nottingham Smith

J. N. SMITH.
Railway-Axle Box.

Patented March 23, 1875.

No. 161,069.

Fig. 3.

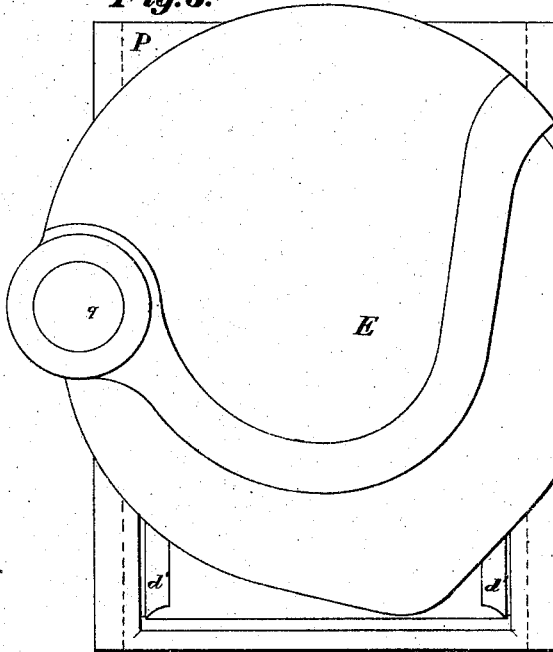

Fig. 4.

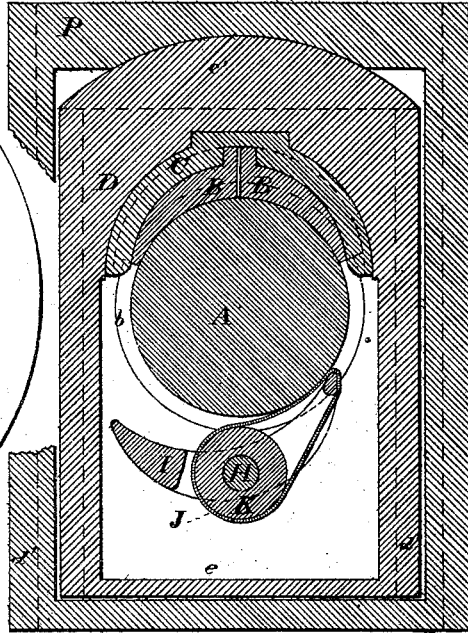

Fig. 5.

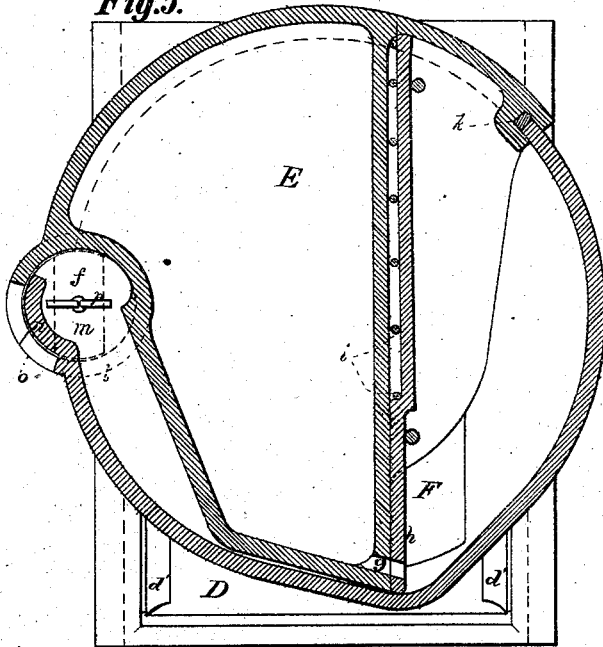

Fig. 6.

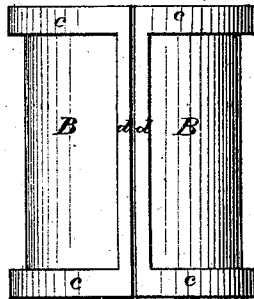
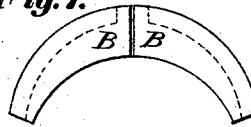

Fig. 7.



Inventor

J. Nottingham Smith

Witnesses
M. A. Murkhead
Wm. C. Rowe

J. N. SMITH.
Railway-Axle Box.

No. 161,069.

Patented March 23, 1875.

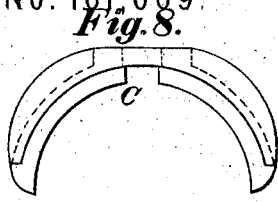

Fig. 8.

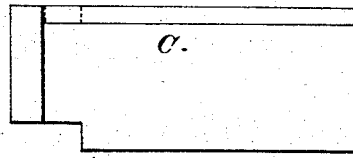

Fig. 9.

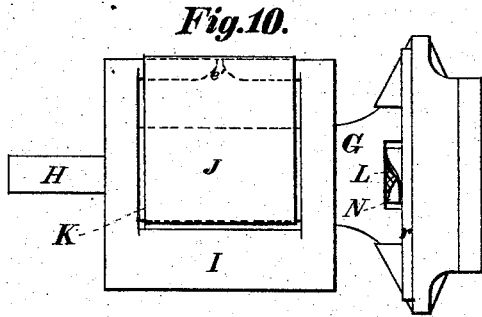

Fig. 10.

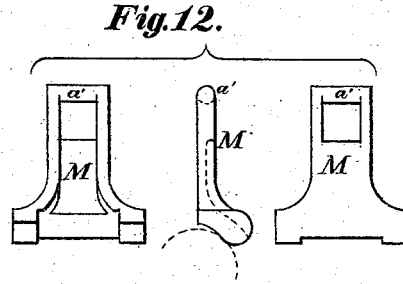

Fig. 12.

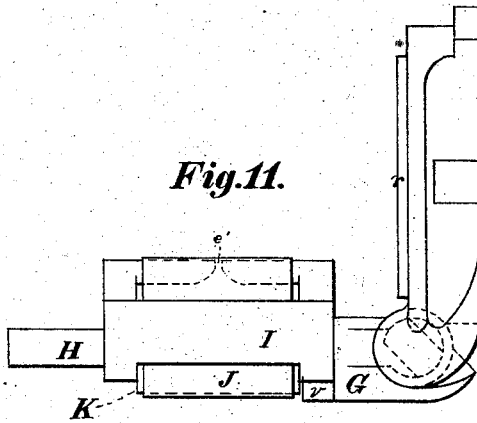

Fig. 11.

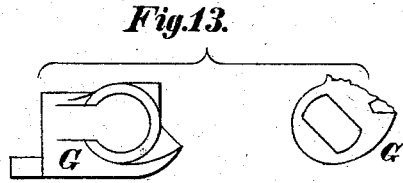

Fig. 13.

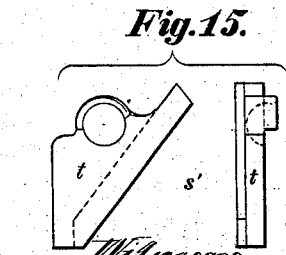

Fig. 15.

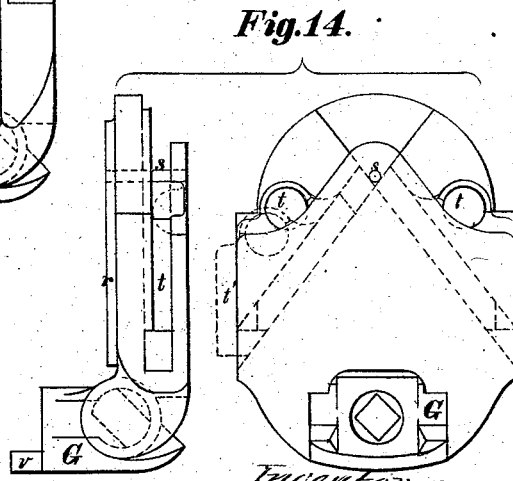

Fig. 14.

Witnesses
W. L. Rowe

Inventor
J. Nottingham Smith

UNITED STATES PATENT OFFICE.

J. NOTTINGHAM SMITH, OF JERSEY CITY, NEW JERSEY.

IMPROVEMENT IN RAILWAY AXLE-BOXES.

Specification forming part of Letters Patent No. 161,069, dated March 23, 1875; application filed December 19, 1874.

To all whom it may concern:

Be it known that I, J. NOTTINGHAM SMITH, of Jersey City, in the county of Hudson and State of New Jersey, have invented certain Improvements in Journal-Boxes for Railroad-Cars, of which the following is a specification:

My invention relates, first, to certain new and improved means whereby the box or bearing is relieved from the strains which tend to twist or turn it on the journal; said strains being occasioned principally by the turning of curves, and acting in planes parallel to the axis of the journal, tend to make the box bind and heat at the ends; second, in the combination, with the lining and the box-frame or housing in which the lining is located, of a removable seat, into which the lining is fitted, whereby the removal and replacement of the lining is greatly facilitated; third, in a new application of a "stopping-bar," to take up the end play of the axle in the box, which is principally due to the lateral swaying of the car; fourth, in new and improved devices for applying oil to the journal, and for making the supply of oil continuous for a considerable length of time, whereby, also, the waste of oil is prevented, and the oil is kept clean and free from grit and dirt; fifth, in an improved form of hinge-joint for attaching the oil-tank to the box-frame, and also for joining the oiling devices, hereinafter described, to the stopping-bar.

In the accompanying drawings, Figure 1 is a side elevation of my journal-box. Fig. 2 is a vertical cross-section of the same through the axis of the journal. Fig. 3 is an end elevation as it appears when looking at the side of the car. Fig. 4 is a vertical cross-section on the line *x x*, Fig. 1. Fig. 5 is a vertical cross-section on the line *y y*, Fig. 1. Fig. 6 is a top view of the bearing-plate or lining, made preferably of brass or bronze, in which the journal runs. Fig. 7 is an end view of the same. Fig. 8 is an end view of a movable plate or seat, into which the lining, Figs. 6 and 7, is fitted. Fig. 9 is an edge view of the same. Fig. 10 is a top view of the stopping-bar, to which are attached the devices for applying oil to the journal. Fig. 11 is a side view of the same. Fig. 12 shows a back, an edge, and a front view of a small tumbler used

in applying oil to the end of the axle, where it bears on the stopping-bar. Fig. 13 shows in detail the hinge-joint by means of which the oiling devices are secured to the stopping-bar. Fig. 14 shows an edge and a side view of a modified form of stopping-bar, in which wedge-shaped bolts are used to support the stopping-bar against the thrust of the axle. Fig. 15 shows a side and an edge view of one of the wedge-bolts used in Fig. 14.

The journal A is made on the end of the axle, in the usual form, having a flange, *a*, at one end of the bearing, and a shoulder, *b*, at the other. The bearing-plate or lining B is fitted in between this flange and shoulder, and thus helps to take up or resist the end play of the axle. The plate B is shown in two parts, as that is considered the most desirable form in which to make it, for the open space thus left between the parts, by breaking the continuity of the bearing-surface, materially aids in preventing the accumulation of heat in the bearing. This plate has its lower side fitted to the journal, and its upper side is fitted into a removable seat, C, which in turn finds its seat or bearing in the frame D. The upper side of the bearing B has ribs or flanges cast on it, as seen at the ends, at *c*, and in the middle at *d*, which ribs or flanges enter corresponding grooves or recesses in the seat C, and serve to retain the bearing-plate B in place, even if broken or worn very thin.

As will be seen in Fig. 7, the form of the bearing-plate B is such that it may be worn nearly through before it becomes necessary to replace it with a new one.

The seat C is also provided on its upper side with ribs or projections, as seen in Figs. 8 and 9, which fit into recesses in the box-frame D, and secure the seat C in place. Instead of using this plate C, the seat for the lining B may be made in the box-frame D, though I consider the construction shown the most convenient, as it greatly facilitates the fitting of new, and replacing of worn-out, bearings. To the outer end of the box-frame D, and closing and fitting into a recess therein, is the oil-tank E, which has an outlet at its lowest point for the escape of the oil into the well or tank *e* in the bottom of the box-frame

D, whence it is conveyed by the oilers to the bearing-surfaces, as hereinafter more fully described. The oil-tank E is hinged at *f* in such a manner that when thrown up for refilling, the outlet *g*, which is ordinarily at the bottom, as shown, is brought to the top, to receive the new supply of oil. The outlet *g* is provided with a sliding valve or cover, *h*, which, when the oil-tank is raised, is closed by a spring, *i*, (shown in dotted lines in Fig. 2, and in section in Fig. 5,) and opened (when the oil-tank is replaced in position for use) by its lower end coming in contact with the bottom of the recess in the box-frame in which the oil-tank rests.

It will be seen that the oil will only escape from the oil-tank when the level of the oil in the well *e* gets below the opening or outlet *g*, so as to admit a small amount of air to the tank. A groove, *k*, is formed around the oil-tank E, where it joins the upper edge of the recess in the box-frame D, into which groove an india-rubber or other suitable packing, *k*, is inserted. This packing rests upon the upper edge of the walls of the recess, thus excluding dust and dirt, while the hinge is so formed as to assist in accomplishing the same result. The construction of this hinge is shown in Figs. 1 and 5. A portion of the barrel or tubular part *l* of the hinge, and also at each end of the barrel portion a lug, (shown in dotted lines at *m*,) are formed on the box-frame, while the remainder of the barrel *n*, and a circular box-shaped opening having a slot, *o*, to admit the lug *m* into the box, are formed on the oil-tank. By throwing up the tank the slot *o* is brought into such a position that the lug *m* may be introduced into the box, and by turning the tank it becomes locked fast to the frame.

To prevent the accidental or improper removal of the tank a wire staple, *p*, having a large circular head, *q*, is passed through holes in the centers of the circular boxes and the lugs and clinched on the inside.

Between the oil-tank and the end of the axle the stopping-bar F is inserted. This stopping-bar is a thick flat plate of metal having a circular bearing-face, *r*, (which may be cast on a chill-plate, if desired,) for the end of the axle to work against. The stopping-bar is backed up by the oil-tank and the box-frame, so as to resist the end thrust of the axle. Should this be in any case insufficient I have provided an additional support in the wedge-shaped bolts *t*. (Shown in detail in Figs. 14 and 15.) These wedge-bolts are fitted into suitable recesses in the edges of the stopping-bar, and are prevented from coming out by the pins and ribs *s'*. When the stopping-bar is in place the two bolts *t* are thrown out sideways, as seen in dotted lines at *t'*, Fig. 14, entering slots or recesses prepared in the box-frame to receive them, thus securely supporting the stopping-bar against the thrust of the axle, and preventing the crushing of the oil-tank by the swaying of the car, or the jam-

ming of it by the same means, so as to prevent its being raised for refilling when the car is standing on a curve.

Attached to the stopping-bar at its lower end by means of a hinge-joint (shown in Fig. 13,) and similar to that above described for attaching the oil-tank to the box-frame, are the devices for conveying the oil from the well *e* to the running surfaces. These oiling devices consist of a bearing-piece, G, in which one end of a bolt or shaft, H, is supported, the other end finding a bearing in the box-frame D; a tumbler or frame, I, hung loosely upon said shaft H, said tumbler being so formed and hung that one side is much heavier than the other, as shown in Fig. 4; a roller, K, having a corrugated or roughened surface, and being keyed to the shaft H; and an endless web or belt, J, of wool or some other suitable fibrous material passing around the roller and the lighter of the two sides of the frame I, as clearly shown in Figs. 4, 10, and 11, and being held up against the journal by the preponderating weight of the heavy side of the frame I. A slot, *e'*, is made in the lighter side of the frame I, to admit the web J. That part of the web J which is in contact with the under side of the roller K is always immersed in the oil, and the oil is drawn up, by capillary action, through the web J, and deposited on the journal A. A stop, *v*, (seen in Figs. 2, 11, and 14,) keeps the tumbler from turning around too far, and thus interfering with the insertion of the oiling devices. Near the outer end of the shaft H is another corrugated roller, L, and in a recess, *w*, in the bearing face *r* of the stopping-bar is a small tumbler or frame, M, having a cylindrical bar or rod, *a'*, at the top. The form of this tumbler M is clearly shown in Fig. 12. Around the bar *a'*, and, with a quarter twist, around the roller L, a second endless band or web of fibrous material, N, is carried. The tumbler M is supported, as seen in Figs. 2 and 12, at a point at a considerable distance outside of a perpendicular let fall from its center of weight, whereby it has a constant tendency to fall inward against the end of the axle. This insures the constant contact of the web N with the end of the axle, while the lower end of the web is constantly immersed in oil, and thereby a continual supply of oil is insured to the bearing-surfaces.

It will be observed that the recess *w* extends above the center of the axle, thus giving the oil an opportunity to distribute itself from the center outward, and utilizing the tendency the oil will necessarily have to fly out from the center when the car is in motion.

The outer end *b'* of the shaft or bolt H is made square, so that a wrench may be applied for turning it. When, by continual running, that part of the belts or webs J and N in contact with the running-surfaces becomes worn or gummed up, another portion of the webs may be brought in contact with the running surfaces by turning the bolt H. To prevent

the dust from entering the inner end of the box-frame D a sliding cover or stop, O, is fitted to the inner end of the box-frame. This cover has a hole in it, slightly larger than the axle, through which the axle passes, and as the lining B wears away the cover O slides up with the axle, thus keeping the inner end of the box-frame tightly closed. The box-frame D, with the bearings, oil-tank, and oiling devices, hereinabove described, attached to it, is connected to the frame P by means of a ball-and-socket joint, so as to be free to follow any motion of the axle except that of rotation, and thus prevent the cramping of the bearings. On the top of the box-frame D there is a spherical or ball-shaped projection, *c'*, which fits into a corresponding recess in the surrounding open frame P, as seen in Figs. 2 and 4. One side of this spherical projection *c'* is cut away, and the lower side of the frame P is tapered, as shown, to permit the box-frame to be inserted in the frame P. The sides of the box-frame D are rounded at *d'*, so as to allow it to swing laterally in the frame P, and thus to follow the lateral swinging of the axle and prevent the bearings from binding. The frame P fits into the jaws or pedestal of cast-iron, which is bolted to the frame of the truck on which the car rests.

I am aware that a railroad-car truck has been patented in which one of the axles is described and shown as arranged in swiveling or ball-jointed boxes; but that was done in order to allow the truck-frame itself to be distorted horizontally from its normal rectangular form in passing curves. This application of the ball-joint I do not claim, as I consider it of the utmost importance to the proper and economical working of a railroad-car truck that its rigidity and power to resist torsion and distortion be preserved.

Having thus fully described my invention, I claim—

1. In a railroad-car truck having a rigid

frame, the ball-and-socket joint interposed between the bearings of the journal and the frame of the truck, in combination with the housing D, the bearings B, and axle A, substantially as and for the purposes set forth.

2. In combination with the box-frame D and journal A, having flanges *a b*, the lining B and seat C, as and for the purposes set forth.

3. In a railroad-car truck, in combination with the journal A and housing D, which is connected to the truck by a ball-and-socket joint, the stopping-bar F, substantially as and for the purpose set forth.

4. The combination of the bolt H, roller K, tumbler I, web J, and oil-well *e*, for oiling the journal, substantially as and for the purpose set forth.

5. The combination, with the stopping-bar having a recess in its bearing-face extending beyond the center of the axle, of the web N, tumbler M, roller L, and bolt H, substantially as and for the purposes set forth.

6. In combination with the box-frame D, well *e*, bearings B and *r*, and oiling devices, the oil-tank E, substantially as and for the purposes set forth.

7. The combination, with the oil-tank E and box-frame D, of the valve *k* and spring *i*, substantially as set forth.

8. The combination, with the oil-tank E and box-frame D, of the packing *k* and hinge *f*, for excluding dust from the box-frame, substantially as set forth.

9. The combination of the stops *t* with the box-frame D and stopping-bar F, substantially as set forth.

10. In combination with the box-frame D, connected to the truck by the ball-and-socket joint, and axle A, the sliding cover O, for excluding dust, &c., substantially as set forth.

J. NOTTINGHAM SMITH.

Witnesses:

W. L. ROWE,
W. MUIRHEAD.