

J. N. SMITH.  
Car-Axle Box.

No. 161,070.

Patented March 23, 1875.

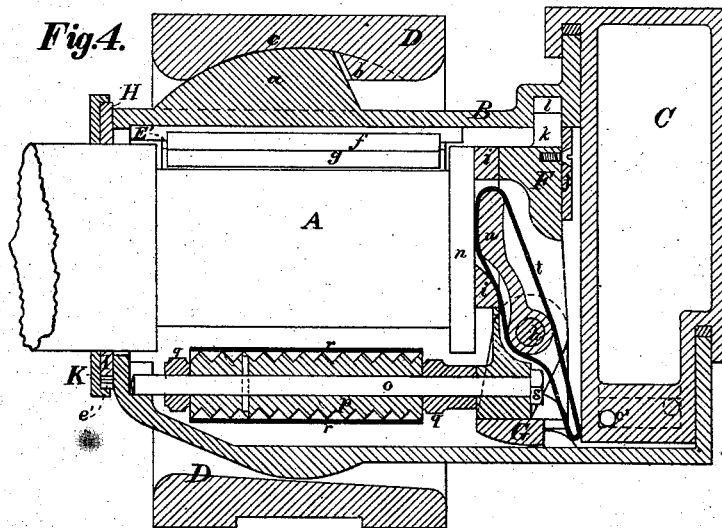
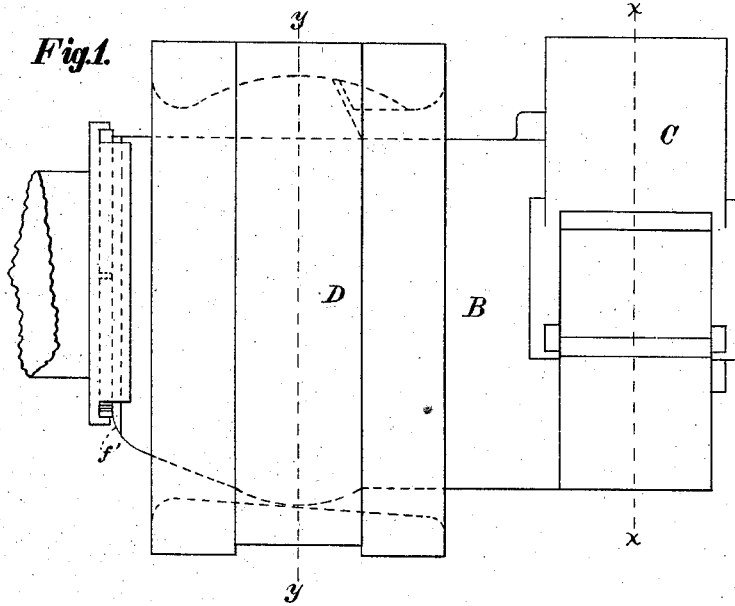

Witnesses:  
D. W. Weston.  
G. W. Bury.

J. Nottingham Smith,  
By H. James Weston,  
Attorney.

J. N. SMITH.  
Car-Axle Box.

No. 161,070.

Patented March 23, 1875.

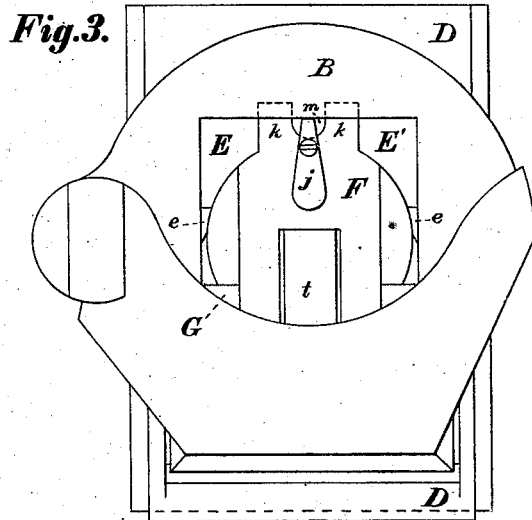
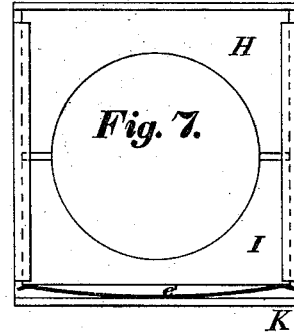
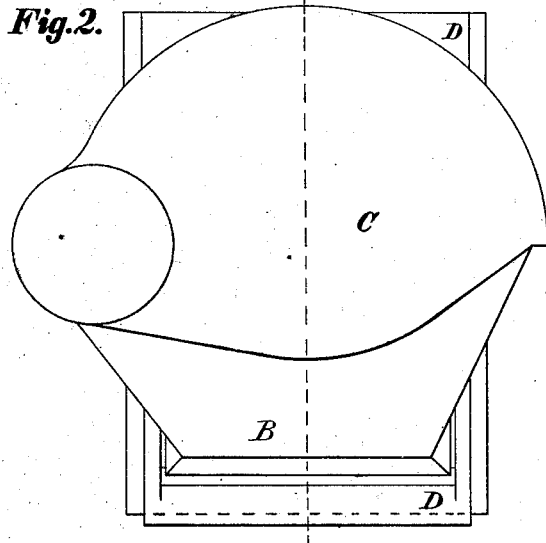

**Fig. 8.**

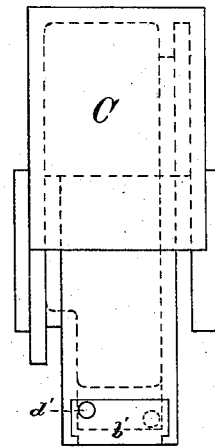

Witnesses:  
D. W. Weston.  
By H. James Weston.

J. Nottingham Smith,  
By H. James Weston,  
Attorney.

J. N. SMITH.  
Car-Axle Box.

No. 161,070.

Patented March 23, 1875.

Fig. 5.

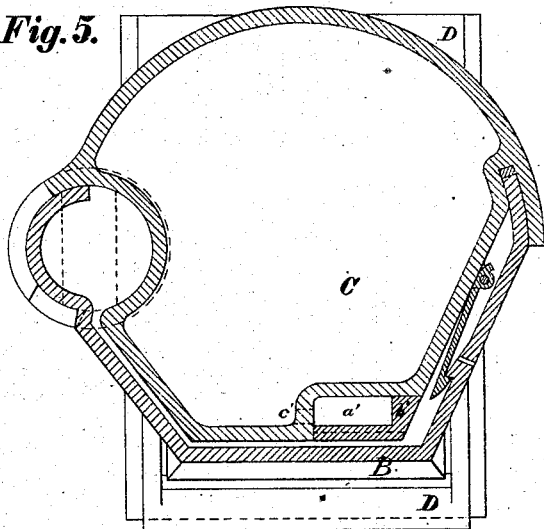

Fig. 10.

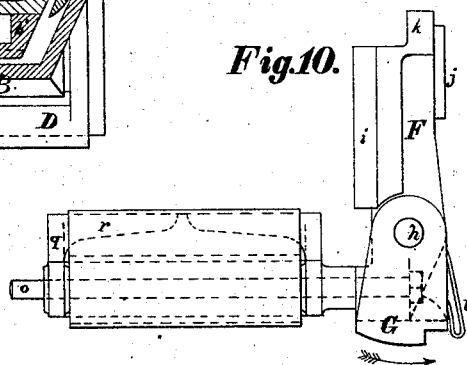

Fig. 6.

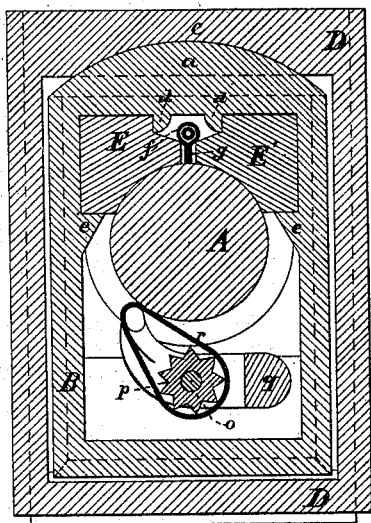
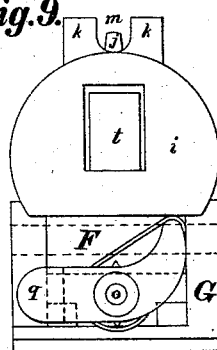

Fig. 9.



Witnesses:  
 D. W. Weston.  
 G. W. Barry.

J. Nottingham Smith,  
 By H. James Weston,  
 Attorney.

# UNITED STATES PATENT OFFICE.

J. NOTTINGHAM SMITH, OF JERSEY CITY, NEW JERSEY.

## IMPROVEMENT IN CAR-AXLE BOXES.

Specification forming part of Letters Patent No. 161,070, dated March 23, 1875; application filed November 19, 1874.

*To all whom it may concern:*

Be it known that I, J. NOTTINGHAM SMITH, of Jersey City, in the county of Hudson and State of New Jersey, have invented certain Improvements in Railway-Car Journal-Boxes, of which the following is a specification:

The improvements of which my invention consists relate to a certain journal-box for the axles of railway-cars, in which the box-frame or casing containing the bearings is connected to the car by a ball-and-socket joint, which permits the said bearings to follow or partake of all motions of the journal except that of rotation on its axis, whereby the bearings are kept always in line with the journal.

My invention consists, first, in the combination, with the male and female parts of the ball-joint, of a lug or projection formed on or in one of the said parts, so arranged as to strike against a shoulder on the other part, and thus prevent undue or excessive motion in the said joint; second, in the combination, with the journal and the said bearings, of a web or curtain of fibrous or other absorbent material, such as sponge, having a roll at its upper edge, preferably of the same or similar material, which rests upon the inner corners of the said bearings, and thus supports said curtain, and having its lower edge nearly or quite in contact with the journal, its object being to absorb any excess of oil and equalize its redistribution to the journal; third, in an improved form of stopping-bar to take up the end play of the axle, said bar being jointed in the middle to facilitate its insertion and removal, and being held in position while in use and supported against the end thrust of the axle by recesses or projections in or on the inner surface of the box-frame or housing, into or behind which the said stopping-bar is placed; fourth, in combination with said journal and stopping-bar, a notch or opening in the top of the latter, through which the journal-bearing may be observed, and the amount of wear determined without removing the said bar; fifth, in combination with said casing or housing and the tank for containing the oil, an intermediate chamber between the said oil-tank and the oil-well, whence the supply for the journals is immediately drawn, with inlet and discharge-openings so arranged that the oil

will be held in the tank and fed out automatically, whether the axle is horizontal or inclined, as when passing a curve, where the outer rail is higher than the other.

In the accompanying drawings, which illustrate a journal-box embodying my invention, Figure 1 is a side elevation. Fig. 2 is an end elevation; Fig. 3, an end elevation, with the oil-tank removed; Fig. 4, a vertical longitudinal section through the center; Fig. 5, a vertical cross-section on the line *x x*, Fig. 1. Fig. 6, a similar section on the line *y y*. Fig. 7 is an inside view in detail of the dust-excluding plate and the frame in which it is held. Fig. 8 is a side elevation in detail, showing the side of the oil-tank which is to the right in Fig. 2. Fig. 9 is an end view, in detail of the stopping-bar and devices for applying the oil to the bearings. Fig. 10 is a side view of the same.

A is the journal, in the usual form, the axle being represented as broken off to save space. B is the box-frame, casing, or housing, in which the bearings are held. The bottom part of it is kept supplied with oil from the oil-tank C, thus serving as a well from which the oil to supply the bearings is drawn. The top of this casing is spherical in form, as seen at *a*, and this spherical part fits into a recess or seat, *c*, formed in the surrounding frame D. The frame D is fitted into the jaws or pedestal of the truck. One side of the part *a* is cut away, as shown, to permit the frame D to be swung on or off when it is not in the pedestal, and a projection, *b*, in the seat *c*, is so formed and arranged as to strike the shoulder on *a* to limit the motion of the ball-joint. By means of this ball-joint the bearings are always free to follow the journal, and thus they always remain in line. E E' are the principal bearings, of any suitable material, cast in the form shown, and fitted into the housing, where they are held by the ledges or ribs *d d* and *e e*. A space is left between them along the top of the journal, and in this space a roll, *f*, of fibrous or other suitable absorbent material is laid. A web, curtain, or wick, *g*, depends from this roll. Its lower edge being close to the surface of the journal, any excess of oil will be caught up by this curtain and conveyed to the roll, whence it will again be fed out, thus equalizing the supply of oil.

F G is the stopping-bar, hinged at *h*, and having a detachable bearing-plate, *i*, fitted to it. The bar is made in two parts, hinged together to facilitate its insertion and removal. It may be removed by turning the button *j* to one side, raising the bar, and throwing up the part G, as indicated by the arrow. The bar is then lowered to clear the ends *k* from the socket *l*, when it can be drawn out of the housing. At the top of the bar F G, and between the ends *k* a notch or opening, *m*, is formed, its bottom being on a level with the top of the flange *n*, on the end of the journal, when the bearings E E' are new.

It is evident that, as the bearings E E' wear away, the flange *n* will appear in sight in the opening *m*, and thus form an index by which the amount of wear may be observed without removing the bar.

To the bar F G are also attached the devices for carrying the oil from the well in the bottom of the housing to the bearings. On the rod *o*, which has a bearing in the part F of the bar, are the roller *p* and tumbler *q*, on which is the wick *r*. This wick is drawn around, when it becomes worn, by means of a wrench applied to the head *s* of the rod *o*. The bearing-face of the stopping-bar and the end of the axle are oiled by the wick *t*, which passes around the tumbler or click *u*, and hangs down in the oil in the oil-well. When worn, it may be drawn around by pulling one side of it down.

At the bottom of the oil-tank C a chamber, *a'*, is formed, partly by the shape of the tank at this point, and partly by the piece *b'*, which may be of wood, and is fitted tightly into grooves made to receive it in the tank, as seen in Fig. 8. The chamber *a'* forms an intermediate space between the oil-tank proper and the oil-well at the bottom of the housing. Its object is to prevent the oil in the tank from all running out when one end or one side of the journal-box is lifted more than the other. A hole, *c'*, connects the bottom of the chamber *a'*, at the side nearest the bearing, with the interior of the oil-tank. Another hole, *d'*, at the opposite side of the chamber *a'*, the bottom of which hole is just below the level of the top of the hole *c'*, allows the oil to flow from the chamber *a'* to the oil-well.

It will be seen that (the journal-box stand-

ing level) when the level of the oil in the well gets down to the bottom of the hole *d'*, the air will pass into the hole *c'*, and permit the oil in the tank to flow out into the chamber *a'*, thus keeping the well always supplied. Should one side or one end of the housing be raised, however, the oil in the chamber *a'* will cover the hole *c'*, or the oil in the well will cover the hole *d'*, and thus prevent the oil in the tank from all running out.

H I is the dust-excluding plate, formed in two parts, which are held in the frame K and kept up against the axle by means of the spring *e'*. The frame K is secured to the inner end of the housing, on which it is free to slide up and down by the ribs *f'* on the housing, which enter grooves in the sides of the said frame, thus making a dust-proof joint, while, at the same time, the plate H I is held so snugly up to the axle, by the spring *e'*, as to prevent the dust entering between the axle and the plate.

I claim as my invention—

1. In combination with housing B, outer frame D, ball-and-socket joint *a c*, the projection *b*, substantially as and for the purpose set forth.
2. In combination with the journal A, bearing-pieces E E', set apart, as shown, and lubricating apparatus below the journal, the roll *f*, and depending curtain *g*, substantially as and for the purpose set forth.
3. In combination with the journal A, and housing B, frame D, and ball-and-socket joint, the stopping-bar F G, made in two parts, connected by a hinge-joint, substantially as and for the purpose set forth.
4. The combination of journal A, bearings E E', and stopping-bar F G, provided with the notch or opening *m*, substantially as and for the purpose set forth.
5. In combination with the oil-tank C and housing B, the intermediate chamber *a'*, connected with the interior of the oil-tank, and with the oil-well by the openings or holes *c'* and *d'*, respectively, substantially as and for the purpose set forth.

J. NOTTINGHAM SMITH.

Witnesses:

W. L. ROWE,  
J. B. BAKER.