

G. L. BAILEY.

Machine for Rounding and Backing Books.

No. 161,089.

Patented March 23, 1875.

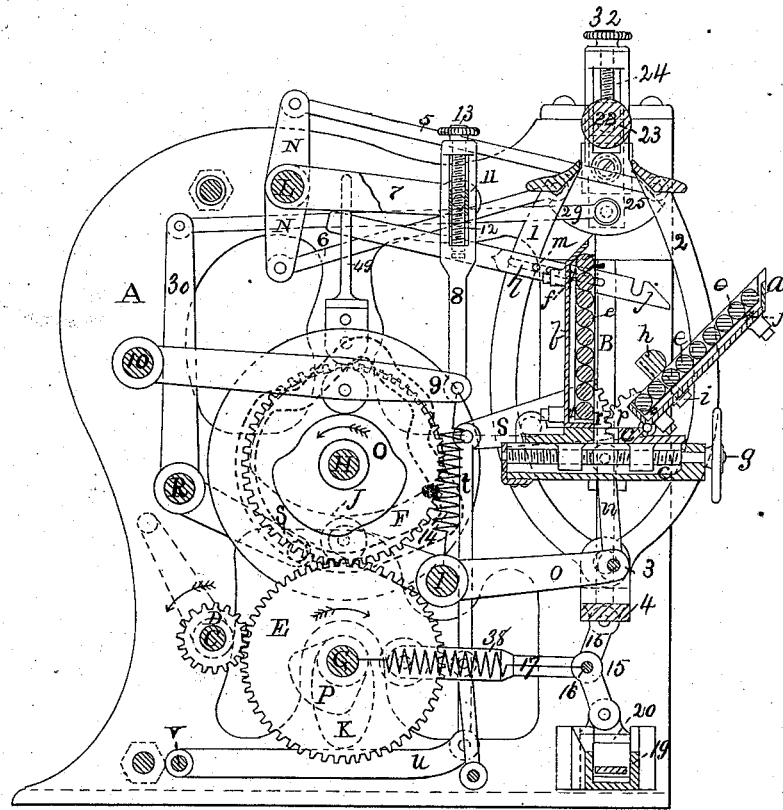

Fig. 1.

Witnesses

W. A. Fambanks

W. E. Brown

Inventor

George L. Bailey
Per W. A. Fambanks, Attorney

G. L. BAILEY.
Machine for Rounding and Backing Books.
No. 161,089. Patented March 23, 1875.

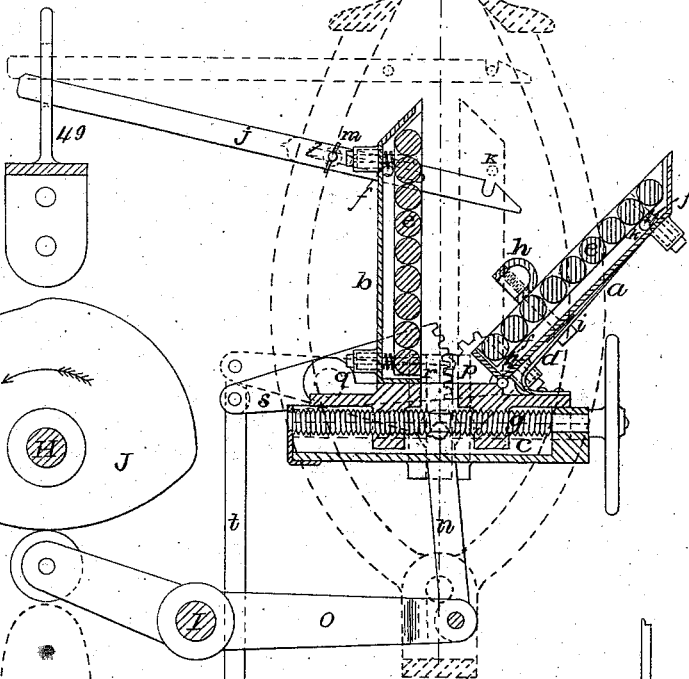
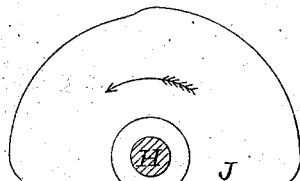
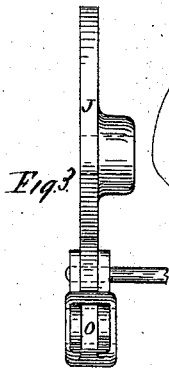
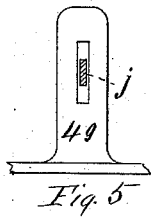
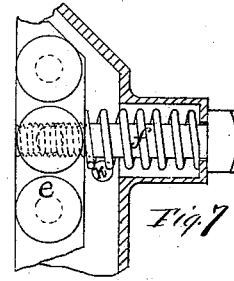
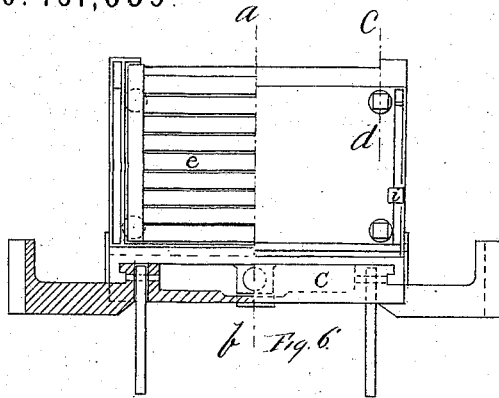
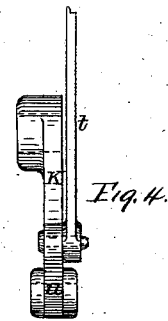

Fig. 2.



Witnesses
H. A. Fairbanks
W. C. Brown

Inventor
George L. Bailey
Per W. C. Brown, Attorney

G. L. BAILEY.

Machine for Rounding and Backing Books.

No. 161,089.

Patented March 23, 1875.

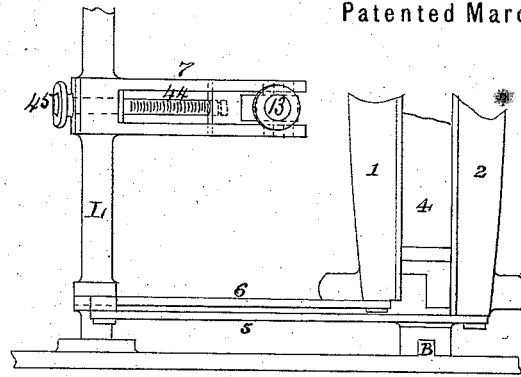

Fig. 10

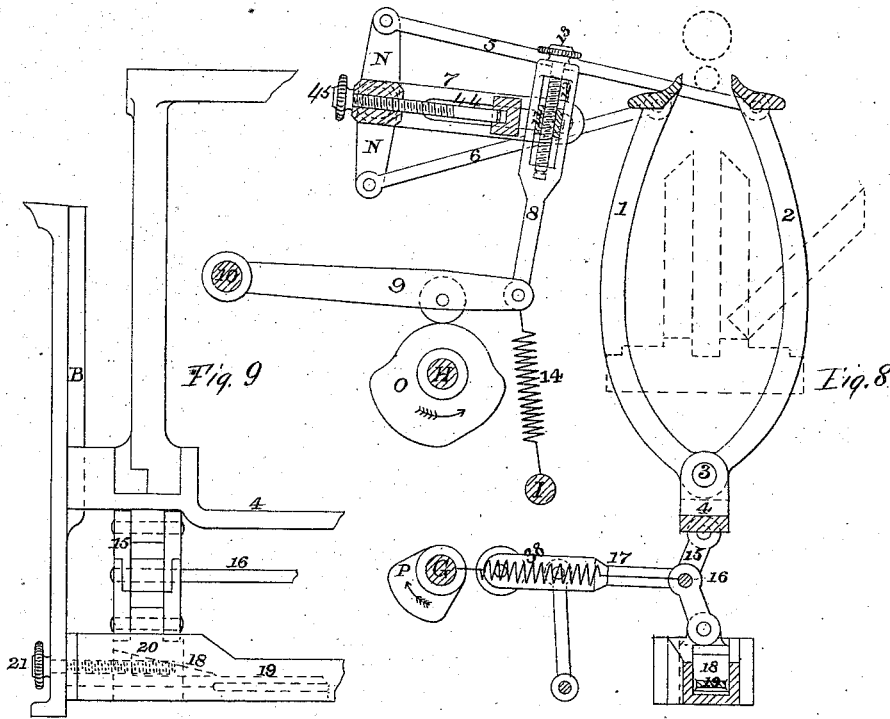

Fig. 9

Fig. 8

Witnesses

H. N. Fairbanks
N. E. Brown

Inventor

George L. Bailey
Per W. H. Trautman, Attorney

G. L. BAILEY.

Machine for Rounding and Backing Books.

No. 161,089.

Patented March 23, 1875.

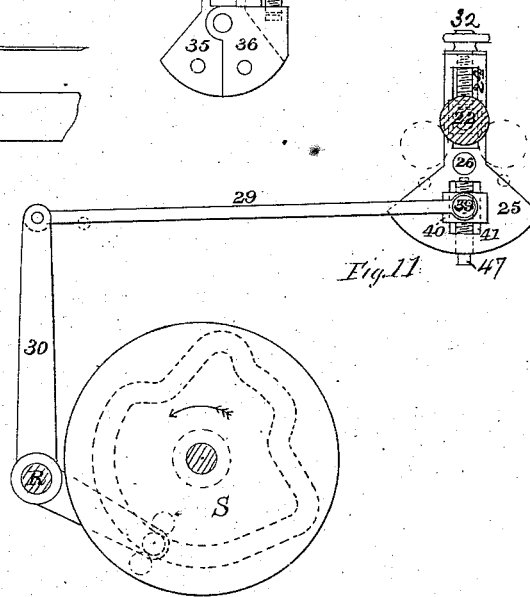
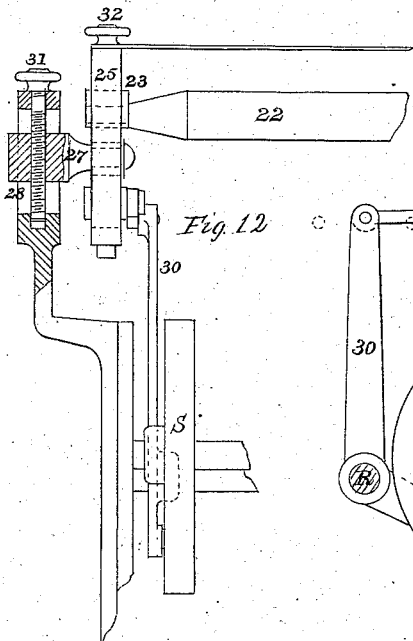
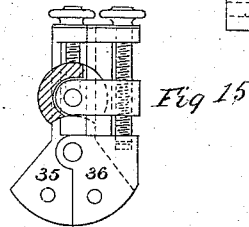
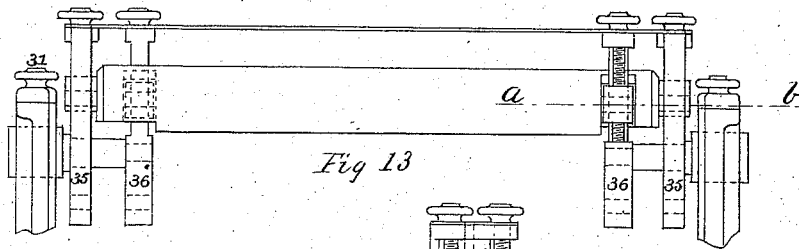
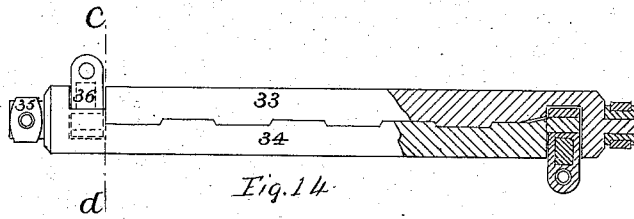

Witnesses
H. A. Fairbanks
W. E. Brown

Inventor
George L. Bailey
Per [Signature]

UNITED STATES PATENT OFFICE.

GEORGE L. BAILEY, OF PORTLAND, MAINE.

IMPROVEMENT IN MACHINES FOR ROUNDING AND BACKING BOOKS.

Specification forming part of Letters Patent No. **161,089**, dated March 23, 1875; application filed December 28, 1874.

To all whom it may concern:

Be it known that I, GEORGE L. BAILEY, of Portland, in the county of Cumberland and State of Maine, have invented certain new and useful Improvements in Machines for Rounding and Backing Books; and I do hereby declare that the following is a full, clear, and exact description thereof, that will enable others skilled in the art to which it appertains to make and use the same, reference being had to the accompanying drawings, forming a part of this specification, in which—

Figure 1, Plate 1, shows a side elevation of my invention partially in section. Fig. 2, Plate 2, shows the book-holder and its operative mechanism partially in section on line *a b* of Fig. 6. Fig. 3, Plate 2, shows a front view of cam *J* and lever *O*. Fig. 4, Plate 2, shows a front view of cam *K*, lever *u*, and connecting-rod *t*. Fig. 5, Plate 2, shows a front view of standard 49. Fig. 6, Plate 2, shows a front view of book-holder. Fig. 7, Plate 2, shows a partial section of book-holder on line *c d*, Fig. 6. Fig. 8, Plate 3, shows a side view of the gripping-jaws and their operative mechanism partially in section. Fig. 9, Plate 3, shows an end view of one side of the jaws, with the lifting-toggle and adjusting-wedge. Fig. 10, Plate 3, shows a top view of one side of the jaws, with the arm 7 and the means of adjusting the throw of the jaws. Fig. 11, Plate 4, shows the rounding and backing roll and its operative mechanism partially in section. Fig. 12, Plate 4, shows a front view of one side of same. Fig. 13, Plate 4, shows a front view of the modification, in which a bisected roll is used, together with its attachments. Fig. 14, Plate 4, shows a plan of said roll, partially in section, on line *a b* of Fig. 13. Fig. 15, Plate 4, shows an end view of said bisected roll, partially in section, on line *c d* of Fig. 14.

Same letters show like parts.

My invention consists of a machine for rounding and backing books, and is intended to perform these operations successively and automatically.

Its general operation is as follows: The book is placed in a hinged holder which opens to receive it. As motion is given to the machine the holder closes and rises vertically, inserting the upper or back edge of the book be-

tween jaws which close upon it lightly and assist in holding it upright. A roll placed over these jaws then moves over the back of the book, pushing the outer leaves downward and bringing the back to a rounded form. The front or lower edge of the book rests or is supported in the holder by a convex former, so that the front of the book is concaved at the same time. By the continued action of the machinery the book-holder rises a second time for a short distance, this time accompanied by the jaws, which, at the same time, are caused to grip the book tightly just under the edge of the back. The roll again moves over the back of the book as before, but with a much increased pressure, owing to the nearer approach of the book, caused by the additional rise of the holder and jaws. This second motion of the roll has the effect of bending the edges of the back over the edges of the jaws, forming the creases seen in books, ready to receive the boards in which they are bound. The work being thus completed, the jaws open, the holder descends and opens, and the book is ready to be removed, rounded, and backed.

By reference to the accompanying drawings the mechanism by which the movements are successively accomplished will be readily understood.

I will first explain the construction of the book-holder. It consists of two parts, *a b*, one of which, *b*, is rigidly attached in an upright position to a carriage sliding on a vertically-moving bed, *c*, while the other, *a*, is hinged to a like carriage. A spring, *d*, closes the hinged part *a* when uncontrolled by the opening devices hereafter explained. The inner surfaces of both parts *a b* are provided with anti-friction devices to give the outer leaves of the book free motion during the rounding process. In the drawing these devices consist of rolls *e*, having behind them springs *f*, allowing them a slight adjustability in order that they may accommodate themselves to books varying slightly in thickness. Both parts *a b* are also so arranged as to slide horizontally to and fro on the bed *c*, enabling them to be adjusted to books varying in thickness to a greater degree. This adjustability is regulated by means of a right-and-left screw, *g*, moving both parts *a* and *b* equally, thus preserving their position

directly under the center of the opening between the jaws hereafter described. Upon one side, *a*, of the holder is placed a former, *h*, to form the front or concave edge of the book. This has a vertical adjustment by means of set-screws *i* at each end moving in slots in the side *a*. For different thicknesses of books formers of different widths may be used. In order to hold the parts *a b* in a closed position after the book is placed between them a latch, *j*, is provided, which operates automatically, engaging a catch or pin, *k*, upon the hinged part *a* when the holder is raised toward the rounding-roll and the parts closed, and releasing said catch when it falls. This latch is adjustable by a slot, *l*, and set-screw *m*, so as to operate when the parts *a b* are adjusted at different distances apart. It is operated by its free end striking against the top of a slotted standard, 49, affixed to the machine. This throws up the opposite end of the latch, it being attached to the part *b* by a pivot upon which it turns, and engages the pin *k* on the part *a*.

I will now describe the mechanism for raising the holder and presenting the book to the roll for the operation of rounding, previous to which some description of the frame and shafting will be necessary.

A shows the frame of the machine, having vertical slides B B, on which moves the bed *c*, upon which the holder is placed. At C is the shaft, to which power is applied, communicating it through a pinion, D, to the gears E F on the shafts G H, respectively, upon which shafts are placed the cams which give motion to the machinery. Returning to the holder, to its bed *c* is attached a connecting-rod, *n*, jointed to a lever, *o*, having its fulcrum on a shaft, I, and extending backward to a point under the shaft H. Upon this shaft H is a cam, J, working against the end of the lever *o* from above. As the shaft H and cam J revolve the cam presses down on the end of the lever *o* and raises the end under the bed *c*, throwing up said bed and the attached holder. The cam J is so constructed as to communicate to the bed and holder two upward motions before they descend to release the book, one motion presenting the book to the roll for the operation of rounding, and the second and additional motion raising it still farther, so as to obtain an increased pressure for backing it, as previously stated. The holder having been thus raised and the other devices hereafter described having operated the cam J by its continued revolution permits the bed and holder to descend, which they do by their own weight. The mechanism for opening the holder and releasing the book now operates. It consists of a segmental gear, *p*, rigidly attached to the hinged part of the holder, and having its center in the pivot on which said holder turns. To the carriage to which this hinged part is attached is secured a plate, *q*, on which is pivoted a second segmental gear, *r*, so as to remain equidistant from, and in engage-

ment with, said gear *p* without reference to the distance apart at which the parts *a b* of the holder may be adjusted. An arm, *s*, attached to said gear *r* is pivoted to a connecting-rod, *t*, attached at its lower end to a lever, *u*, hinged upon a rod or shaft, *v*, extending across the machine. When the moment arrives for releasing the book a cam, K, upon the shaft G presses downward upon the lever *u*, drawing down the connecting-rod *t* and the arm *s* of the gear *r*, causing said gear to describe an arc of a circle, and throwing the gear *p* in an opposite direction, thus causing the hinged part *a* of the holder to open. As the revolution of the cam K continues the lever *u* is released, and the spring *d* before mentioned throws the part *a* back into an upright position, closing the holder.

I will now describe the operation of the jaws 1 2: These are hinged, at 3, to a frame, 4, which has a vertical motion on the slides B B of the frame A already mentioned. They open and close automatically, but to a more limited extent than the holder. They have but one upward motion—viz., when the book is ready to be backed after being rounded—but have two closing motions, one shutting over the book lightly as it is thrust upward and between them by the holder, for the purpose of being rounded, and the other gripping the book hard when the same is to be backed. This last is simultaneous with the rising movement of the jaws and with the second rising movement of the holder.

I will describe the mechanism for closing the jaws: Across the frame of the machine, at L, extends a shaft provided at each end with double levers N extending above and below it. To these levers are attached rods, 5 6, one, 6, reaching from the lower arm of the levers N to the inner jaw 7, and the other, 5, from the upper arm of the levers N to the jaw 2. As the shaft L is turned it will be seen that the upper arms of the levers N draw in or push out the jaw 2 through the connecting-rods while the lower arms of the lever have the contrary effect on the jaw 1, thus causing them to open and close. To this shaft L is rigidly attached an arm, 7, pivoted to a downwardly-projecting rod, 8, in such a manner as to allow its point of connection to be vertically adjustable. This rod 8 is pivoted, at its lower end, to an arm, 9, attached to a shaft, 10. This arm 9 rests upon, and is moved by, a cam, O, upon the shaft H. As the shaft and cam revolve the latter raises the arm 9 and the rod 8 pivoted thereto, thereby raising the rigid arm 7 and turning the shaft L, thus opening or closing the jaws, as above described. Said cam O is, like the cam J which operates the book-holder, provided with two successively-operating projections, one closing the jaws lightly upon the book while it is being rounded and the second causing the tighter gripe needed when the book is to be backed. I have referred to the adjustability of the point of con-

nection of the arm 7 and rod 8. The effect of this is to lengthen or shorten the rod 8 between the arm 7 and the arm 9, the result being to change the angle at which the arm 7 stands; drawing back or advancing the levers N and the rods 5 6, and varying the space between the jaws. This is necessary in order to adjust them to different thicknesses of books, and in this case I provide for the adjustment by pivoting the arm 7 to a box, 11, sliding in a slot, 12, in the rod 8, and raised or lowered by a thumb-screw, 13, passing through the top of said rod 8.

The throw of the jaws 1 2 may also be adjusted by giving to the rod 8 a longitudinal movement in the arm 7. This can be done by giving the point of connection a sliding adjustment in a slot, 44, in the arm 7, and regulating it by a thumb-screw, 45. This is substantially the same as the vertical adjustment, and is shown in Fig. 10, Plate 3. The arm 7 being so arranged that the operation of raising it closes the jaws 1 2, it follows that when drawn down said jaws will be opened. This is accomplished by means of a spring, 14, or like device attached to the arm 7 or some of its connections.

I will now describe the devices for raising the jaws. Under the frame 4, to which they are hinged are placed toggle-joints 15 15, pivoted on a common and movable rod, 16, and operated by rods 17, which, when thrown forward, straighten said joints, and throw up the frame and attached jaws. These rods 17 extend backward toward the shaft G, upon which are cams P P, which, when the proper time comes for raising the jaws, press forward against the ends of the rods 17 and straighten the toggles, forcing up the jaws, as described. This operation is simultaneous with the second closing or gripping motion of the jaws before explained, and is a part of the operation of backing the book or preparing it for the boards. The toggles are drawn back so as to permit the jaws to descend by means of a spring, 38, attached to the movable rod 16, to which they are pivoted, which spring operates when the rods 17 are released from the pressure of the cams P P. The upward movement of the jaws is rendered adjustable to a slight degree—a great range of adjustability is unnecessary—by means of wedges 18 18, fixed on a bar, 19, sliding under the blocks 20, to which the lower ends of the toggles are secured. These wedges may be drawn in or out by means of a screw, 21, raising or lowering the toggles.

Coming now to the operation of the roll which rounds and backs the book, I will state that it passes over the back of the book one or more times for each operation. The drawing represents a machine in which the roll passes over once. The first time, or during the process of rounding, the book is held in the book-holder, the jaws merely serving to keep it upright, and the action of the roll is for the purpose of pressing the outer leaves down over the convex former, which the anti-

friction devices of the holder enable it to do. The second motion of the roll is for the purpose of backing the book, when a more forcible application is required, the book being held tightly in the jaws, and the object being to form the creases in the sides and to spread the back outward over the edges of the jaws forming the recess for the boards. The movement of the roll in both cases is precisely similar, so that one description will answer for both operations.

The roll, which I will designate as 22, is hung in boxes 23, capable of vertical motion in a groove, 24, of a swinging frame, 25, which frame is hung on pivots 26 attached to blocks 27, also capable of vertical motion in grooves 28 in the frame of the machine. To the swinging frame 25, below its point of attachment to the frame A, is pivoted a connecting-rod, 29. This rod, at its other extremity, is pivoted to the upper arm of a bell-crank, 30, moving upon a shaft, R, extending across the machine. The other end of this crank is provided with a stud moving in a path-cam, S, by means of which the bell-crank is oscillated at the proper times, communicating motion, through the connecting rod 29, to the swinging frame 25, which moves the roller over the book, rounding or backing it, as the case may be. The object of hanging both roll and swinging frame in such a way as to give them a vertical motion is to render them adjustable, so that the radius upon which the roll moves may be increased or diminished to accommodate it to different thicknesses of books without changing the distance between the roll and the jaws 1 2. This adjustability is regulated by screws 31 32 passing through the top of the frame in which the boxes slide, and drawing said boxes up or down at pleasure. To increase the radius, the boxes in which the roll is hung are raised by their screws 32, raising the roll, and increasing the distance between it and the pivots on which the frame 25 swings. This increases the radius, but at the same time increases the distance between the roll and the jaws. To remedy this, the blocks 27 are depressed by their screws 31, lowering the frame 25, pivoted to them, together with the roll, thus restoring the relative position of the roll and jaws, while the radius remains increased.

The arc of the circle through which the roller moves may be increased or diminished, as shown in Fig. 11. In this the pivot 39, by which the connecting-rod 29 is attached, the swinging frame 25 is secured to a block, 40, sliding vertically in groove 41 within said frame, and adjustable at any point by a set-screw, 47.

Beside the single roll shown in the drawings, I contemplate a modification of the machine, consisting of the substitution of a roll divided longitudinally into two parts, opening from the top where the book is to be backed or rounded, and rolling down over the book from the center of the back outwardly. This

device is illustrated in the drawings, Figs. 13, 14, and 15, Plate 4.

When this modification is used, the half-rolls 33 34 would be mounted on separate frames 35 36. The mechanism giving motion to these frames would be similar to that used with the single roll, save that it would be in duplicate, two connecting-rods and bell-cranks being necessary at each end of the roll, each driven by its own path-cam. Two screws at each end would be required, instead of the adjusting-screws 32, as in Figs. 13 and 15, and the rolls would have to be so arranged as to turn on a common center, as shown in the sectional part of Fig. 14.

It will be understood that many of the parts mentioned herein are in duplicate, so that both ends of the machine may operate steadily simultaneously, but in some cases, for the purposes of description only, one set of devices has been described.

The movements of the various parts are either simultaneous or successive, as the work requires, as set forth in the preliminary or general description of the invention.

What I claim as my invention, and desire to secure by Letters Patent, is—

1. The book-holder provided with anti-friction devices for holding the book, whereby the outer leaves of said book are allowed free motion to accommodate themselves to the action of the roll during the process of rounding.

2. The book-holder, provided with anti-friction devices having an automatic adjustment by means of springs, whereby they adapt themselves to books varying slightly in thickness.

3. The hinged book-holder, in combination with the segmental gears *p*, *r* cam *K*, and connecting mechanism, whereby said holder is opened after the book is rounded and backed.

4. The book-holder, provided with anti-friction devices, as set forth, in combination

with the convex former vertically adjustable therein.

5. The hinged book-holder, in combination with the adjustable latch *j*, catch *k*, and stand 49, operating to lock the holder when the same is raised.

6. In a machine for rounding and backing books, a holder for said book, provided with operative mechanism whereby two distinct and successive upward motions are imparted thereto, one presenting the book to the roll for the operation of rounding, and the second and additional motion raising it still farther for the operation of backing, in combination with a swinging roll by which both these operations of rounding and backing are performed, substantially as herein described.

7. In combination with the vertically-rising book-holder, the jaws 1 2, combined with operative mechanism, whereby, as the holder rises to present the book to the roll for the operation of rounding, said jaws close upon it lightly, and support it in an upright position during the operation.

8. In combination with a book-holder provided with anti-friction devices, as described, convex-former, and guiding-jaws 1 2, the swinging roll and its operative mechanism.

9. In a machine for rounding and backing books the vertically-rising holder, in combination with the vertically-rising and gripping jaws and swinging roll, whereby the book is raised, gripped, and backed, after being rounded, substantially as set forth.

10. The jaws 1 2, in combination with the toggle-joints and adjusting-wedges.

In testimony that I claim the foregoing I have hereunto set my hand this 11th day of December, 1874.

GEORGE L. BAILEY.

Witnesses:

WM. FRANKLIN SEAVEY,
ALEXR. DENNETT, Jr.