

P. HINKLE.

Vacuum Relief-Valve for Water-Pipes.

No. 161,121.

Patented March 23, 1875.

Fig. 1.

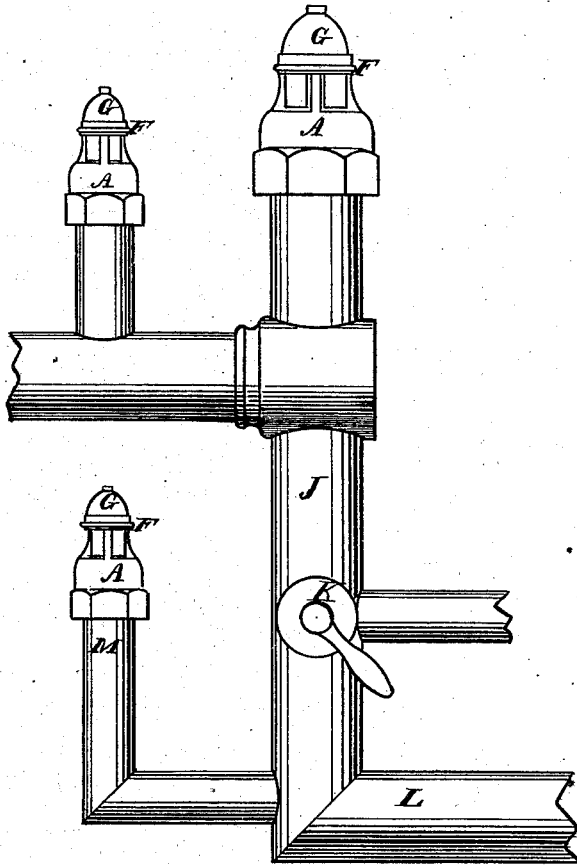
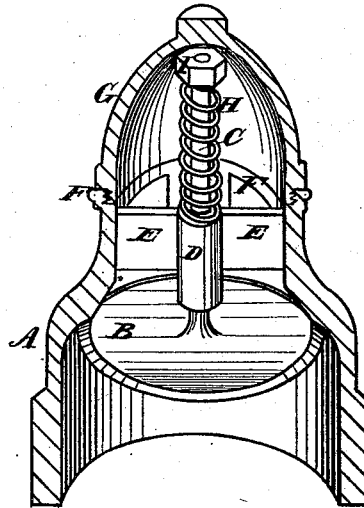

Fig. 2.



Witnesses

Geo. H. Strong.
Jno. L. Boode

Inventor

Philip Hinkle
by Dewey & Co.
attys

UNITED STATES PATENT OFFICE.

PHILIP HINKLE, OF SAN FRANCISCO, CALIFORNIA.

IMPROVEMENT IN VACUUM RELIEF-VALVES FOR WATER-PIPES.

Specification forming part of Letters Patent No. 161,121, dated March 23, 1875; application filed January 30, 1875.

To all whom it may concern :

Be it known that I, PHILIP HINKLE, of San Francisco city and county, State of California, have invented a Vacuum Relief-Valve for Water-Pipes; and I do hereby declare the following description and accompanying drawings are sufficient to enable any person skilled in the art or science to which it most nearly appertains to make and use my said invention without further invention or experiment.

My invention relates to a novel relief-valve for water-pipes, by which I am enabled to prevent the heavy jar caused by the sudden shutting off of running water in pipes where a vacuum is produced by its running.

My invention consists of an inwardly-opening valve suitably attached, and which is kept closed by a light spring and the pressure of the water inside the pipe. When this latter pressure is removed by the vacuum caused by the flow of the water the pressure of air outside of the valve will open it and allow air to enter and relieve any jar.

Referring to the accompanying drawing for a more complete explanation of my invention, Figure 1 is a view, showing the method of using my valve. Fig. 2 is a vertical section, showing the interior of the case and the valve.

A is a valve-chamber, which may be fitted to screw upon the water-pipe in any suitable place. I prefer to secure it to a short section of pipe above or at one side of the main pipe, and have illustrated it as so placed. Within this chamber is situated the valve B, which has a guiding-stem, C. This stem passes through the guide D, which is supported by the surrounding standards E and the rim F at the top. The whole device is surrounded by an ornamental cap, G, which screws down upon the rim F. A spring, H, surrounds the stem C above the guide D, acting between the guide and a nut, I, upon the top of the

stem. This spring serves to hold the valve B closely to its seat with a light pressure, and when there is a water-pressure within the pipe the pipe will be retained more or less closely, according to the pressure of the water.

The operation will be as follows: Let J represent a water-pipe, and K a valve admitting water to an elevator-cylinder or hydrant. L is the pipe through which the water flows beyond the cock, or may be discharged after having done its work. The flow of water in this pipe often causes a vacuum, and when the water is shut off suddenly the recoil causes a jar, which is unpleasant, and sometimes bursts the pipes. My valve is connected with this pipe, and may be secured to a short section of pipe, as at M, so that when the pressure of the water is removed any tendency to cause a vacuum will be counteracted by the opening of this valve to admit air.

An elastic cushion is thus provided, which prevents any unpleasant results from the shutting off of the water.

In cases where there are a number of cocks opening from the same pipe the operation of drawing water from one will often cause the same vacuum and jar when it is stopped, and my valve can be applied at any one or more of these cocks to relieve it.

Having thus described my invention, what I claim, and desire to secure by Letters Patent, is—

The air-chamber A, valve B, stem C, guide D, spring H, and screw-nut I, in combination with the water-pipe J and stand-pipe M, substantially as and for the purpose described.

In witness whereof I hereunto set my hand and seal.

PHILIP HINKLE. [L. s.]

Witnesses:

GEO. H. STRONG,
C. M. RICHARDSON.