

C. W. LEVALLEY.
Harvester.

No. 161,132.

Patented March 23, 1875.

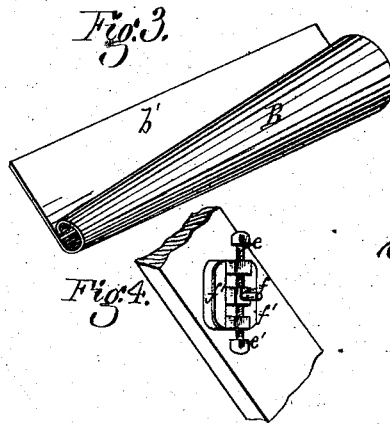
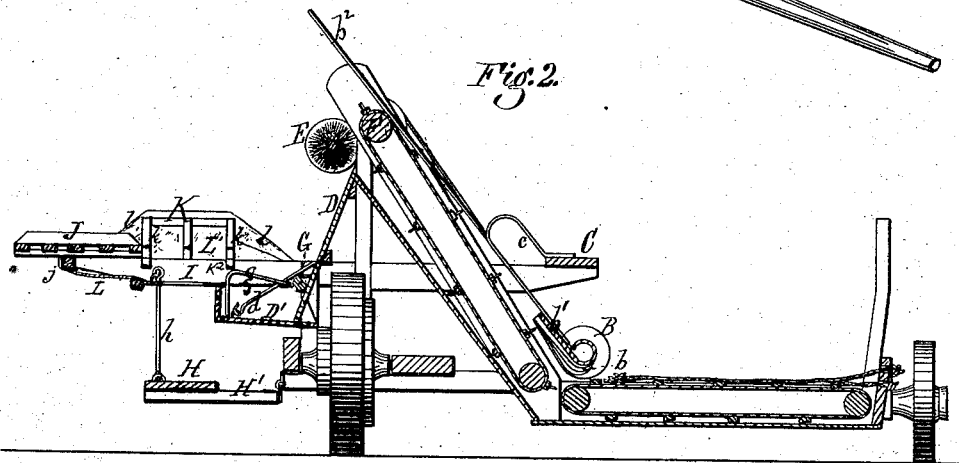
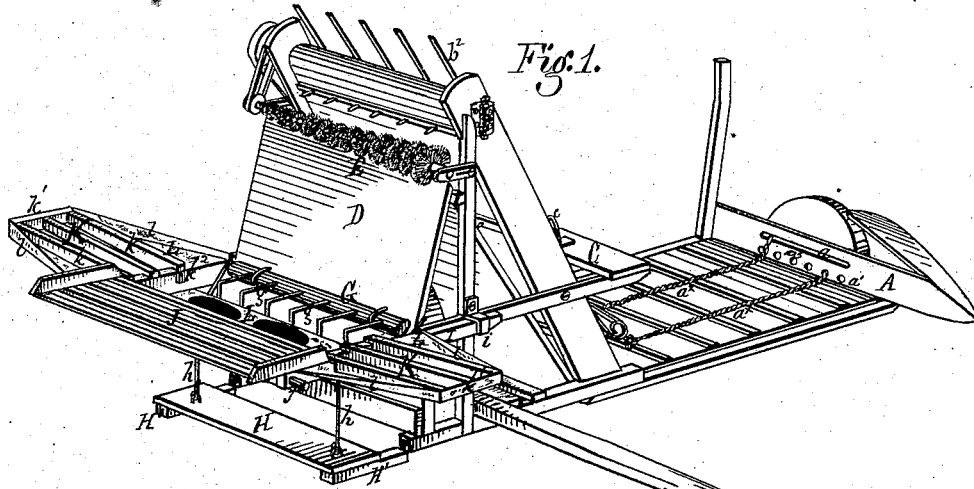

WITNESSES:
Alec Mahon
H. C. Barclay

INVENTOR:
Christopher W. Levalley,
by A. M. Smith
Attorney.

UNITED STATES PATENT OFFICE.

CHRISTOPHER W. LEVALLEY, OF ST. PAUL, MINNESOTA.

IMPROVEMENT IN HARVESTERS.

Specification forming part of Letters Patent No. 161,132, dated March 23, 1875; application filed December 22, 1874.

To all whom it may concern:

Be it known that I, CHRISTOPHER W. LEVALLEY, of St. Paul, county of Ramsey, State of Minnesota, have invented certain new and useful Improvements in Harvesting-Machines, of which the following is a full, clear, and exact description, reference being had to the accompanying drawing, making part of this specification, in which—

Figure 1 represents a perspective view of the improved machine, taken from the front main-frame corner. Fig. 2 is a vertical transverse section through the same looking to the rear. Fig. 3 is a perspective view of the scroll-bar or mouth-piece at the lower end of the elevator; and Fig. 4 is an enlarged perspective view of a portion of the elevator-frame, showing the devices for effecting the adjustment of the upper elevator-roller.

Similar letters of reference denote corresponding parts of the machine whenever used.

The invention consists, first, in a novel construction of the bar which forms the mouth-piece to the elevator, or underneath which the grain passes in being transferred from the platform-apron to the elevator, said bar being made in one continuous piece or sheet rolled into scroll form, and made tapering from rear to front, in such manner as to offer an increased resistance to the passage of the heads of the grain, for the purpose of straightening the straw prior to its being acted upon by the elevator, as hereinafter explained. The invention further consists in making the stripping-brush at the delivery end of the elevator-apron tapering from front to rear, for giving a backward thrust to the grain, and at the same time causing the butts to fall in advance of the heads. The invention further consists in a novel construction of the binders' tables, and of the dumping platform or table, whereby the grain shattered out in the process of binding is conducted into a suitable receptacle therefor, as hereinafter fully set forth.

Other improvements in details of construction and arrangement of parts will be hereinafter described.

The invention relates to that class of machines employing endless platform and elevator aprons, and in which the grain is bound by hand by binders riding on the machine;

and in its organization and general arrangement of parts the machine is similar to others in common use, and therefore need not be described, except in so far as is necessary to an understanding of my improvements.

It is well known to those familiar with the practical working of this class of machines that great difficulty is experienced in causing the grain or straw to be carried evenly across the platform-apron, owing to the fact that the barbed heads adhere more closely to the traveling apron, and are thus made to travel therewith, while the smooth butts, resting as they necessarily do upon the stationary finger-bar or forward platform-bar, are retarded thereby, and caused to slip on the apron, and thus to travel more slowly than the heads, thus causing the grain to assume an oblique position as it approaches the discharging end of the said apron with the heads considerably in advance, thus making it difficult for the elevator to take it up and carry it forward and upward to the binders.

One object of the present invention is to remedy this difficulty, and to this end the outer dividing-board A of the platform is provided with a longitudinal slit, *a*, or series of perforations *a'*, through which a rod, wire, or cord, *a^x*, passes, and is secured by a knot, head, or nut at its outer end. This cord rests upon the surface of the platform-apron, underneath or slightly in advance of the heads of the grain resting thereon, and, serving to lift them slightly off said apron, causes their movement to be retarded by the frictional resistance it offers. This rod or cord may be moved forward or backward by sliding it in the slot *a*, or changing it from one to another of the perforations *a'* to adapt it to the length or condition of the grain, and for increasing or diminishing its action on the heads, as may be found necessary. At the inner end of the platform-apron is located a scroll-bar, B, made tapering in form from rear to front, and supported by springs *c c* from the overhanging seat-plank C in such manner as to allow it to yield or spring upward, where such movement is necessary, to permit the passage of the grain or straw underneath it. This scroll-bar is, by preference, rolled into the form of an elongated frustum of a cone

from a single sheet of metal, and is provided on its lower face with a series of curved cleats or retarding-wedges, *b*, conforming to the curved lower face of the bar. These cleats may be made to increase in thickness or diameter toward the rear end of the scroll-bar, if desired, for increasing the pressure upon, and frictional resistance to, the passage of the heads of the grain, and may either be formed separately from, and riveted to, the scroll-bar, or may be struck up therefrom, as preferred. The increased diameter of the scroll-bar itself, at its rear end, tends to arrest, or partially arrest, the movement of the heads of the grain, giving the butts an opportunity of overtaking them, and thus assists in the operation of straightening the straw before it reaches the elevator-apron.

The inner edge *b*¹ of the sheet of which the scroll-bar is formed extends upward a short distance on a line parallel with the elevator-apron, or thereabout, and forms the point of attachment of the supporting-springs *c*, and also of the retaining rods or wires *b*² supported thereby. Underneath the upper end of the elevator-apron, and at the junction therewith of the inclined shield *D*, over which the grain descends to the binders' grain-table or receptacle, is located a stripping-brush, *E*, arranged to rotate in contact with, or in close proximity with, the said apron, for removing the grain which might otherwise adhere thereto. This brush is made tapering from front to rear, and has the bristles or fine wires of which it may be formed arranged in a spiral form, like the thread of a screw, a simple form of construction of this brush being to clamp the wires or bristles between two wires or rods twisted together, the direction of the twist or spiral being such that the rotation of the brush outward or away from the apron causes a rearward movement of the thread or spiral, thus tending to draw the straw toward the rear end of the stripper-brush. This is found important, from the fact that the swinging movement before given to the straw in attempting to straighten it has a tendency to crowd it forward. The enlargement of the forward end of the brush, as explained, gives a more rapid movement to its surface, besides bringing it first into action upon the straw, and this causes the butts of the grain to be first acted upon, and these, being moved farther and more rapidly, are discharged, and descend over the shield *D* slightly in advance of the heads, thus crowding the straw still farther to the rear, and causing it to descend upon the binders' receptacle in better and more even shape.

The shaft of the upper roller *F* of the elevator-apron at each end passes through a slot in the elevator-frame and is mounted in blocks *f*, which move in vertical ways at *f*¹, (see Fig. 4,) and are held at any desired point of adjustment by means of set-screws *e e*, for regulating the tension of the elevator-apron and also of the driving belts or chains which op-

erate said roller, and therefrom the stripper-brush *E*, as shown, thus avoiding the use of tightening-pulleys. The lower end of the inclined chute or shield *D* has a shallow box, *D'*, hinged to it in such a manner as to permit the box to be folded up into a vertical position against the shield for transportation, the shield or chute forming the inner side of the box when the machine is in operation, and the box is let down to receive the grain shattered out in the process of elevating and binding. When thus let down, as shown in Fig. 2, the outer side of the box is supported by hooks *d*, connected at their inner upper ends with the elevator-frame. Above the box *D'*, and in suitable brackets or bearings connected with the shield *D*, is a rod or roller, *G*, to the outer face of which a number of angular rods or fingers, *g*, are secured, said fingers, when the machine is in operation, extending outward horizontally, or nearly so, to a point nearly over the outer edge of box *D'*, where they are bent downward at about right angles, and have their lower ends resting upon the bottom of the box, which is thus made to support the wires in the desired position for causing them to receive and hold the grain discharged by the elevator.

The binders' platform or stand consists of a longitudinal plank, *H*, mounted upon two transverse bars, *H'*, hinged at their inner ends to the outer longitudinal bar of the main frame in such manner as to permit the platform to be folded into a vertical position for transportation. The outer edge or side of the platform, when in use, is supported by hooks or links *h* connected at their upper ends with the pivoted overhanging bars *I*, which are also pivoted to permit them to be turned upward into a vertical position, being prevented from falling below a horizontal position when the machine is at work by stirrups *i* connected with the elevator-frame, and overhanging the heel extensions of the bars *I* beyond their pivots. A dumping-tray, *J*, for holding the bound bundles until a sufficient number has accumulated to form a shock, is pivoted in the outer ends of the arms *I*, said tray being, by preference, composed of a number of light longitudinal slats connected at their ends with transverse bars, which are secured to a longitudinal pivotal bar, *j*, as shown. To this pivotal bar *j* an apron or canvas, *L*, is connected by its outer edge, said canvas extending over the platform *H*, and being connected at its inner lower edge with the outer vertical side of the shattered-grain receptacle *D'*.

The canvas has openings in it, over the binders' stand, as shown, to accommodate the binders standing on the platform *H*. The binders in depositing the bundles on the dumping-tray place them with the butts outward, so that when the tray is tilted for dumping them they fall upon the butt ends, and in this position on the tray the heads overhang the canvas *L*, which catches any grain that may have been thrashed out in binding, and

become detached in depositing it upon the tray, and causes it to be deposited in the box D'.

Between the tray J and the shield D, and outside of the bars I, in front and in rear, are two tables, K, composed of longitudinal bars *k*, united at their outer ends by a transverse bar, *k*¹, and connected at their inner ends with the bars I by angular stirrups or hooks *k*², or by bolts or pins as preferred.

The tables K are capable of being detached entirely from the bars I, or may be swung downward or upward upon hinges or joints for convenience of entering upon the binders' stand, or for discharging shattered grain, or for transportation. Underneath and around each of these open table-frames K is placed an apron or canvas, L', turned up at its edges *l*, and expanded in width toward the inner end where it is connected with the bar I. The bars *k* being thus raised above the canvas permit the hands of the binder to pass freely between them without meeting any impediment or being inconvenienced thereby. The bars *k* incline slightly toward their inner ends and the canvas L', inclining with them, is left open at one point underneath the bar I, and the grain shattered out in the process of being bound on the bars or tables K passes out underneath the bars I, and is received either directly, by the box D', or it may be deposited by the aprons L' upon the apron L, and carried by said apron to said box D', as preferred.

Having now described my invention, what I claim as new, and desire to secure by Letters Patent is—

1. The grain or divider board A, provided with the longitudinal slot *a* or its equivalent, in combination with the adjustable retarding-rod or cord *a*^x, substantially as described.

2. The scroll-bar B, made tapering in form, and operating in combination with the platform-apron, substantially as described.

3. The stripper-brush E, made tapering from front to rear, in combination with the elevator-apron, substantially as and for the purpose described.

4. The shattered-grain receptacle or box D', formed in part by the inclined chute-board D, and hinged thereto independently of the binders' stand, in combination with the hinged grain-receiving fingers *g*, arranged above the box D' and supported at their outer ends, when in working position, by said box, as described.

5. The slatted dumping-tray J and tables K, arranged in the described relation to each other and to the binders' stand and shattered-grain receptacle D', in combination with the aprons L L', arranged to discharge the shattered grain gathered from the said tables to the receptacle, as described.

In testimony whereof I have hereunto set my hand this 9th day of December, A. D 1874.

CHRISTOPHER W. LEVALLEY.

Witnesses:

THOS. COCHRAN, Jr.,
THEO. E. BLASE.