

M. J. SEYMOUR.

Machine for Jointing Staves.

No. 161,162.

Patented March 23, 1875.

Fig. 1

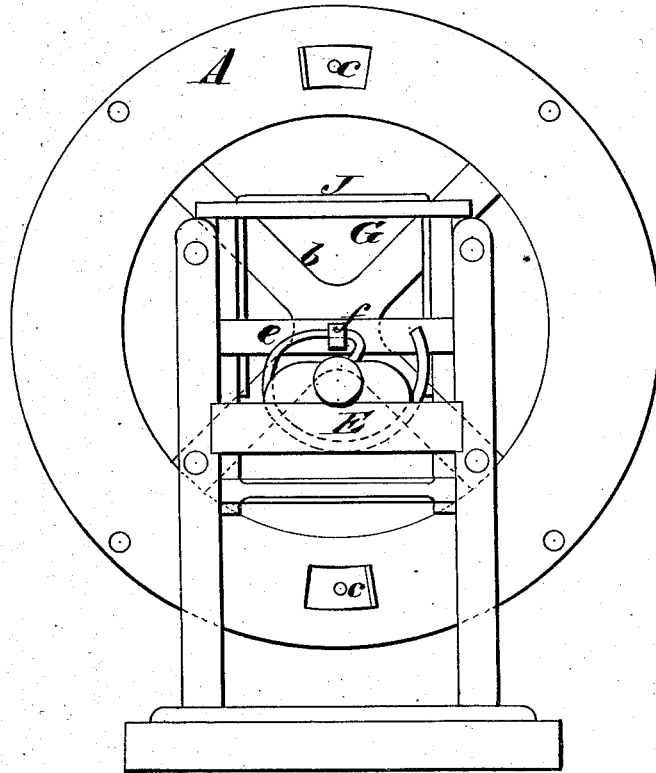

Fig. 2

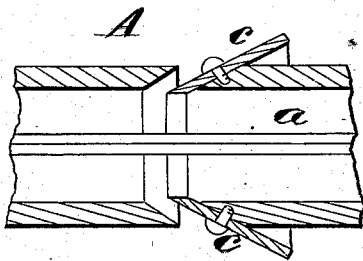

Fig. 3

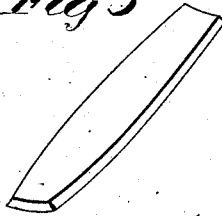
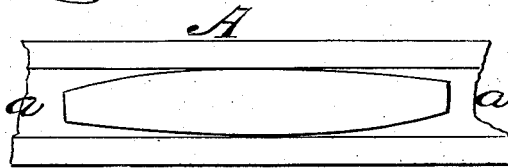

Fig. 4.



WITNESSES

E. H. Bates
George C. Uphaus

INVENTOR

Marvin J. Seymour,
Chipman & Co.

ATTORNEYS

M. J. SEYMOUR.

Machine for Jointing Staves.

No. 161,162.

Patented March 23, 1875.

Fig. 5

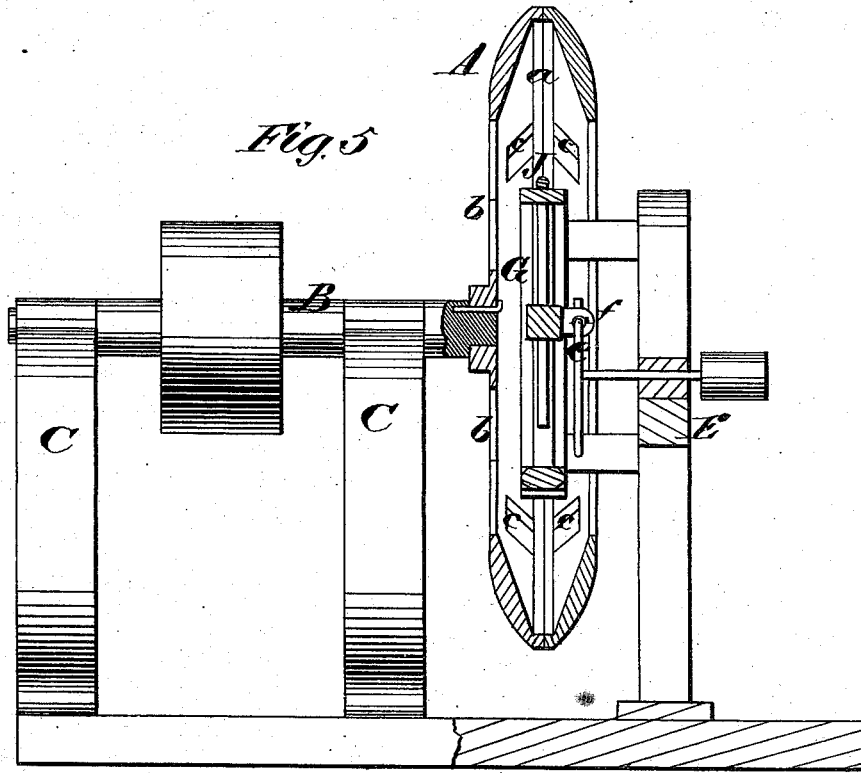
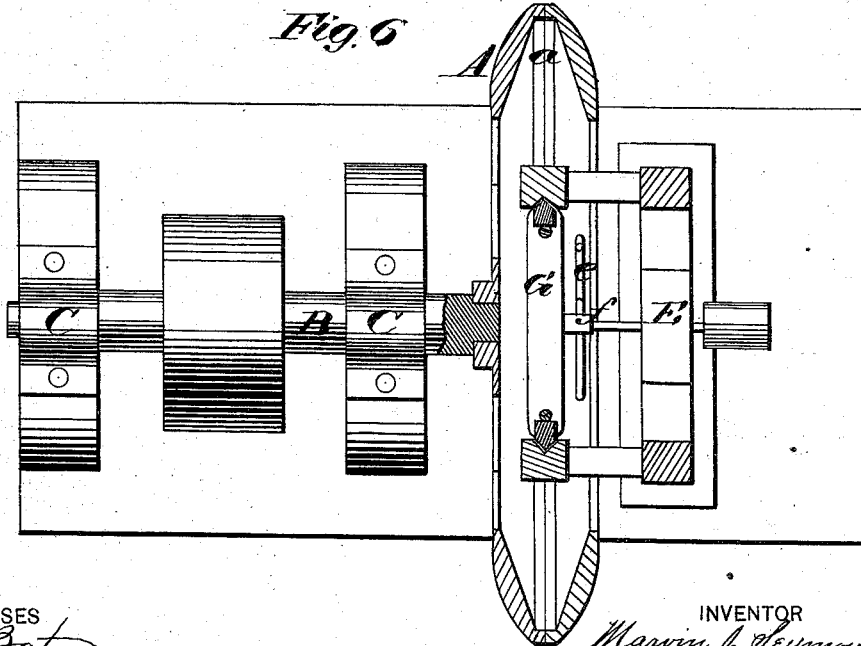

Fig. 6



WITNESSES
E. H. Bates
George E. Upham

INVENTOR
Marvin J. Seymour
Chipman & Seymour
 ATTORNEYS

UNITED STATES PATENT OFFICE.

MARVIN J. SEYMOUR, OF TARR FARM, PENNSYLVANIA.

IMPROVEMENT IN MACHINES FOR JOINTING STAVES.

Specification forming part of Letters Patent No. **161,162**, dated March 23, 1875; application filed February 6, 1875.

To all whom it may concern:

Be it known that I, MARVIN J. SEYMOUR, of Tarr Farm, in the county of Venango and State of Pennsylvania, have invented a new and valuable Improvement in Machines for Jointing Staves; and I do hereby declare that the following is a full, clear, and exact description of the construction and operation of the same, reference being had to the annexed drawings making a part of this specification, and to the letters and figures of reference marked thereon.

Figure 1 of the drawing is a representation of a side elevation of my stave-jointer, and Figs. 2, 3, and 4 are detail views of the same. Fig. 5 is a vertical sectional view, and Fig. 6 is a horizontal sectional view.

This invention has relation to machines which are designed for jointing staves; and it consists in a revolving wheel, having an interior annular groove formed in it, which, in a cross-section through the wheel, is V-shaped, and also having cutters applied in its sides, in combination with a sliding gate, and a clamp for holding the blanks while they are being jointed, as will be understood from the following description:

In the annexed drawings, A designates a wheel, which consists of two rings suitably secured together, and so constructed that they form an interior groove, *a*, which, in cross-section, is V-shaped, as shown in Figs. 5 and 6. This wheel is rigidly secured to a driving-shaft, B, by means of radial arms *b*, which are formed on one of the rings of the wheel, which shaft has its bearings in pillow-blocks C C.

At suitable points on the two rings of wheel A, throats are made, in which cutters *c* are secured, the inner cutting-edges of which have the same angle as the sides of the

groove *a*, for the purpose of giving the proper bevel to the edges of the staves.

By reference to Fig. 4 it will be seen that when a stave is adjusted in the groove *a* in a plane which is tangent to the wheel A, the sides of the groove conform to the curves of the edges of the stave which are necessary to give the proper bilge to the cask. Thus it will be seen that where the stave-blanks are properly introduced into the groove *a*, their longitudinal edges will be beveled, and also curved, to give the proper bilge to the cask for which the staves are designed.

G designates a rectangular frame or sash, which is vertically adjustable between guides by means of a scroll, *e*, which plays through a swivel-eye, *f*, the stem of which scroll turns in a bearing on a cross-bar of a frame, E. J designates an adjustable clamp, which is designed to receive and hold the stave-blanks while they are being jointed.

I do not confine my invention to a vertically-movable sash, as this sash may be moved in any other direction; nor do I confine myself to the precise construction of clamp J for holding the blanks; neither do I confine myself to the device shown for raising and lowering the sash G.

What I claim as new, and desire to secure by Letters Patent, is—

The beveled groove *a* in the wheel A, combined with cutters *c* and a stave-blank holder, substantially as described.

In testimony that I claim the above I have hereunto subscribed my name in the presence of two witnesses.

MARVIN J. SEYMOUR.

Witnesses:

WM. MCNAIR,
H. L. BLACKMORE.