

I. T. SHERRILL.
Car-Coupler.

No. 161,165.

Patented March 23, 1875.

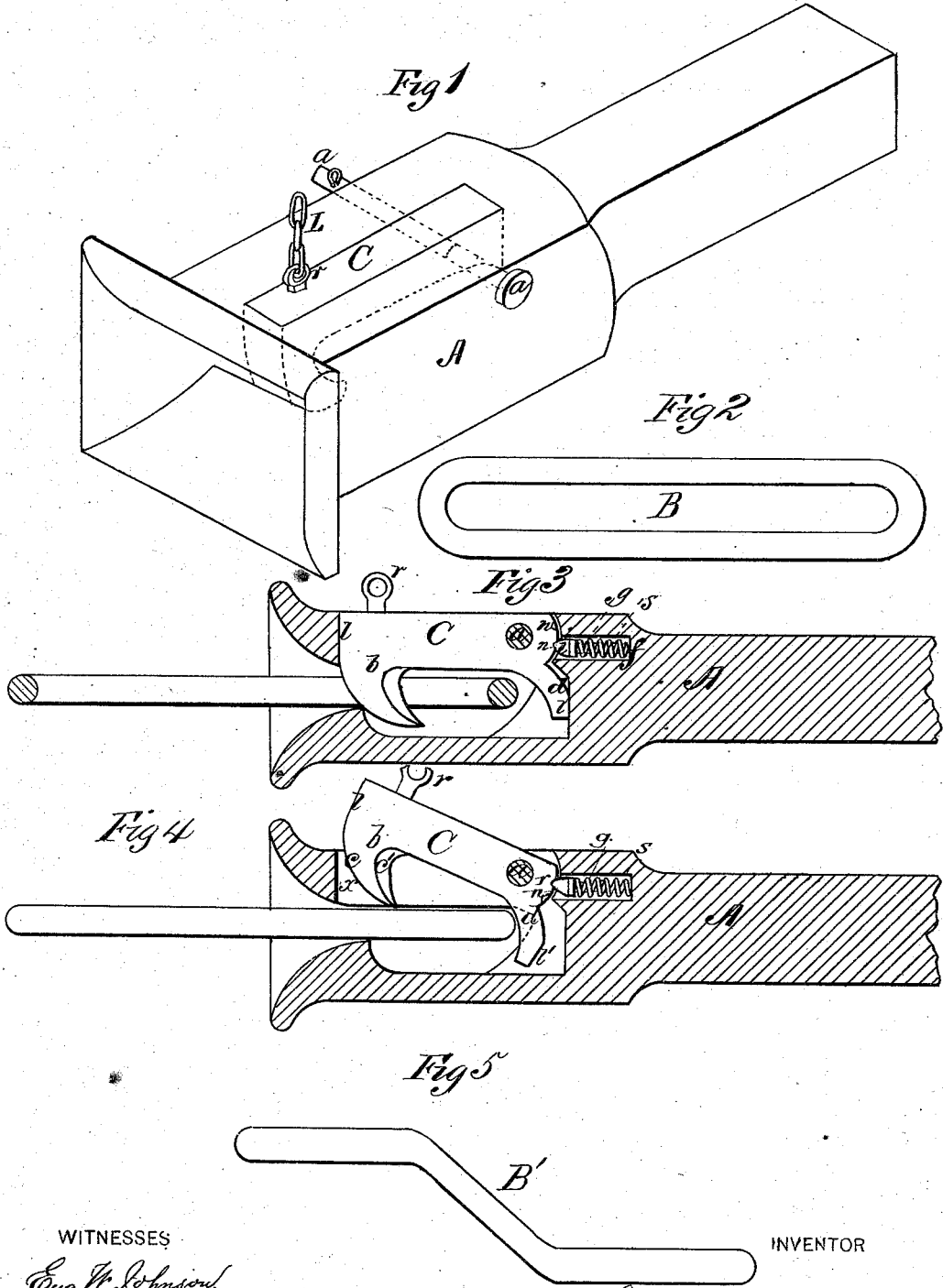

WITNESSES
Eng. W. Johnson
E. H. Bates

INVENTOR
Ira T. Sherrill
Chipman & Co
ATTORNEYS

UNITED STATES PATENT OFFICE.

IRA T. SHERRILL, OF PADUCAH, KENTUCKY.

IMPROVEMENT IN CAR-COUPLERS.

Specification forming part of Letters Patent No. **161,165**, dated March 23, 1875; application filed February 13, 1875.

To all whom it may concern:

Be it known that I, IRA T. SHERRILL, of Paducah, in the county of McCracken and State of Kentucky, have invented a new and valuable Improvement in Car-Couplers; and I do hereby declare that the following is a full, clear, and exact description of the construction and operation of the same, reference being had to the annexed drawings making a part of this specification, and to the letters and figures of reference marked thereon.

Figure 1 of the drawing is a representation of a perspective view of my car-coupler. Fig. 2 is a plan view of the coupling-link, and Figs. 3 and 4 are longitudinal vertical sectional views of the coupler. Fig. 5 is a detail view.

This invention has relation to improvements in automatic car-couplers; and the nature of my invention and improvement consists in certain improvements in connection with vertically-vibrating couplers, as will be hereinafter more fully set forth.

In the annexed drawings, A designates a preferably rectangular-chambered draw-bar, in connection with which and the usual well-known straight coupling-link B, or the equally well-known bent link B', I propose to show my improvements, whereby any of the pin-and-link couplers may be rendered automatic, and the usual noisy rattling common to automatic couplers may be dispensed with. In pursuance of this purpose a rectangular slot is cut through the upper wall of the draw-bar, into which is snugly fitted a coupling device, C, in the nature of a hook, which coupler is secured in place by means of a bolt, *a*, passing through a perforation in the rear end of the said coupler, registering with similar perforations in the lateral walls of the draw-bar. It is thus rendered capable of vertical vibration. The front end of coupler C is provided with a hook, *b*, projecting downwardly, having a convex front edge, *c*, and a concave rear edge, *c'*, and its rear end has a downwardly-projecting lip, *d*, having a concave front edge, *e*. By this means when the link of a car approaching to be coupled strikes the front edge *c* of the hook of coupler C, the latter will be vibrated vertically upward on its pivot *a*, allowing the said link to penetrate into the interior of the draw-bar, until, coming

in contact with lug or lip *d* on the rear end of the said coupler, it will act upon the same as upon the power end of a lever, thrusting it rearwardly, and causing the hook to vibrate downward into the slot of coupling-link, thus effecting a coupling automatically.

In practice, the rear upper part of coupler C must be convex, and must be received into a correspondingly-concave depression in the rear end of the slot *x* in the upper wall of the draw-bar. I propose to utilize this necessary construction for the purpose of locking the coupling-hook C into the position shown in Fig. 3, or that shown in Fig. 4, in the following manner, to wit: A preferably cylindrical recess, *f*, of suitable dimensions is cut horizontally in the concave depression at the rear end of the slot, into which is inserted a coiled helical spring, *s*. Through this spring the shank of a locking-rod, *g*, having an enlarged conical or conoidal head, *i*, is passed, which rod has a certain degree of endwise play therein. The rear end of arm C is provided with notches *n*, into which the pointed head *i* of rod *g* is adapted to engage, as shown in Figs. 3 and 4, the said rod being held to this engagement by the recoil of the said spring, which is compressed by the broadened head of the rod.

In this device coupler C is not, and is preferably not, a gravitating-hook, but fits snugly within its slot, and is actuated, as above described, to effect a coupling. By this means it is prevented from all lateral displacement or rattling, and the line of draft is held strictly in the line of the length of the draw-bar.

It should also be observed that the front upper part *l* of the hook is vertical to the length of the coupler, and fits accurately into, and abuts closely against, the front end of the slot, as shown in Fig. 3, and it is thereby held against outward displacement, while all inward displacement is prevented by the abutting of the rear rectilinear edge *l'* against the rear vertical wall of the draw-head chamber. Coupler C being held, as above described, against both lateral and endwise displacement, its pin *a* is strictly confined to a pivotal function, and is hence not liable to be bent when the said coupler is subjected to strain, which bending, either to the front or rear, would pre-

vent the coupler from coming into position, and occasion its disabling. An uncoupling may be effected without going between the cars by means of a cord or chain, L, attached to a ring, r, on the coupler, extending to the top of the cars.

What I claim as new, and desire to secure by Letters Patent, is—

The combination, with a vertically-vibrating coupler, C, having a convex rear end, with

notches n, of the endwise movable rod g, and spring S, recessed into the draw-head, substantially as specified.

In testimony that I claim the above, I have hereunto subscribed my name in the presence of two witnesses.

IRA T. SHERRILL.

Witnesses:

A. H. SPENCE,
BRICE H. HUSBANDS.