

G. HOOKHAM.

Method of Applying Caps to the Heads of Screws.

No. 161,231.

Patented March 23, 1875.

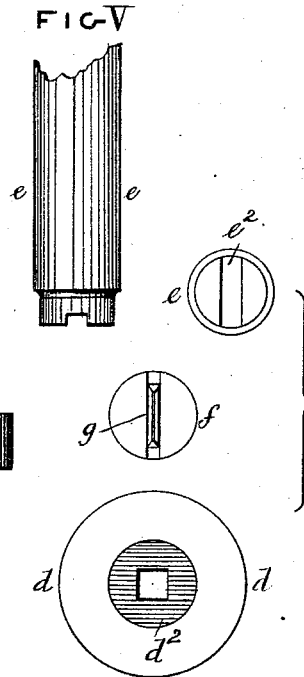
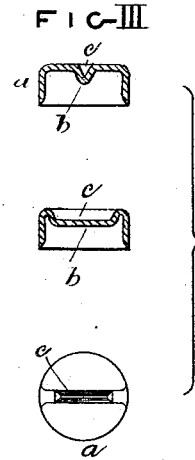
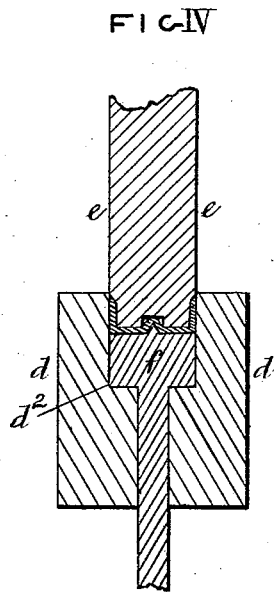
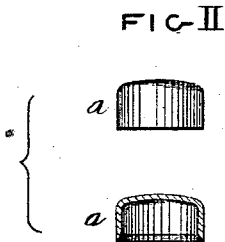
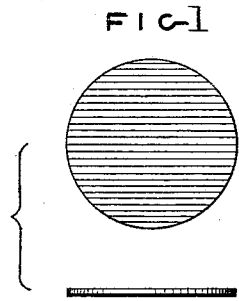

Witnesses,
Richard Kerrett
Henry Kerrett

Inventor
George Hookham

G. HOOKHAM.

Method of Applying Caps to the Heads of Screws.

No. 161,231.

Patented March 23, 1875.

FIG-VI

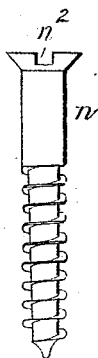

FIG-VII

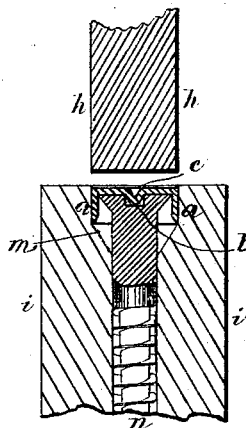

FIG-VIII

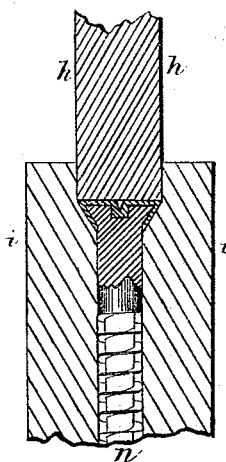

FIG-IX

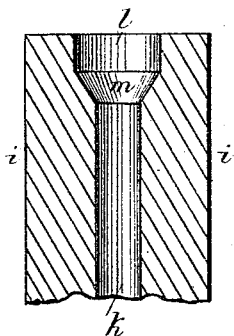
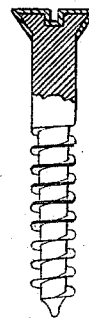

FIG-X



Witnesses,
Richard Skerrett
Henry Skerrett

Inventor
George Hookham

UNITED STATES PATENT OFFICE

GEORGE HOOKHAM, OF BIRMINGHAM, ENGLAND, ASSIGNOR OF ONE-HALF HIS RIGHT TO ALFRED LUDLOW, OF SAME PLACE.

IMPROVEMENT IN METHODS OF APPLYING CAPS TO THE HEADS OF SCREWS.

Specification forming part of Letters Patent No. **161,231**, dated March 23, 1875; application filed February 8, 1875.

To all whom it may concern :

Be it known that I, GEORGE HOOKHAM, of Birmingham, in the county of Warwick, England, manufacturer, have invented Improvements in the Manufacture of Screws, and in machinery or apparatus to be employed in the said manufacture, of which the following is a specification :

The object of my invention is to cover the heads of iron screws with a covering of brass or other metal or alloy, of such a thickness and so applied as to permit of the said brass covering being finished by the process of turning in a lathe, and of receiving a nick similar to that made in the head of a solid brass screw.

I will describe my invention as applied to screws having heads similar to those of ordinary wood-screws.

In carrying my invention into effect, I take iron screws having heads smaller than usual, the said heads having large nicks in them. I make a series of cylindrical brass caps by cutting out disks from sheet metal and raising them by dies and pressure into a cup-like form, the size of the said caps being such that they fit loosely on the heads of the iron screws. The said brass caps are of such depth that when their sides are compressed, as herein-after explained, so as to fit tightly on the conical under side of the head of the screw, they cover or nearly cover the whole of the said under side of the head. In order to effect the said compression and consequent fixing of the brass cap on the head of the iron screw, I employ machinery or apparatus constructed as follows: The said machinery or apparatus consists essentially of a pair of tools working in a press. The lower tool consists of a die on the bed of the press having a hole in its axis. The diameter of the lower part of the hole is of a size proper to receive the stem of the screw, and the diameter of the upper part of the said hole is slightly larger than that of the brass cap to be fixed on the head of the screw. The upper and lower parts of the said hole in the die pass into one another by a conical shoulder having the figure which it is desired to give to the under side of the brass covering of the head of the screw.

A light coiled spring is placed at the bottom of the hole in the lower die. To the screw or ram of the press a cylindrical tool is fixed of slightly less diameter than the upper part of the hole in the lower die.

In using the said machinery or apparatus an iron screw with a brass cap placed or dropped on its head is put into the fixed lower die, the point end of the screw resting on the coiled spring described, so as to support the screw with its head a short distance above the conical shoulder described in the lower die. The upper die descending, the screw and cap are carried down, and the said cap is compressed with great force between the upper tool and the conical shoulder in the lower die. By this compression the metal forming the mouth of the brass cap is gathered in and compressed upon and fixed to the head of the screw, and its outer surface fashioned to the required figure by the conical shoulder of the fixed die. The brass on the top of the head of the screw is also forced into the nick. The upper tool may have on its acting face a projecting rib crossing its center, and the screw is so placed in the lower die that the said rib shall be exactly over the nick in the head of the iron screw. This cross-rib forces the brass cap into the nick in the head, and by the mark it leaves on the said brass cap indicates where the nick has to be made in the said cap; or a depression may be made in the cap before it is placed upon the head of the screw, in which case the cross-rib on the punch is not required. The head of the screw which has thus been covered with brass is finished by turning and nicking in the ordinary manner. It is necessary that the nick in the brass head should descend onto the nick in the iron head, so that on driving home or withdrawing the said screw the screw-driver shall have the same hold on the head as upon the head of an iron screw.

Although I prefer to apply a covering of brass to the heads of iron screws, in the manner described, yet a brass covering may be applied to the heads of iron screws by casting. The head-coverings applied by the casting process are afterward treated by dies and pressure, as hereinbefore described.

Instead of compressing, fixing, and shaping the brass covering on the head of the screw by means of a press, a stamp may be used with like effect.

The shanks of the screws may be protected from rust by galvanizing or tinning, or other protecting process.

I will now describe, with reference to the accompanying drawings, the manner in which my invention is to be performed.

I cut from sheet-brass, by means of a punch and lower die or tool, a blank or circular disk of the kind represented in Figure 1. By means of a drawing-through process, effected by drawing-through tools of the ordinary kind, the blank or disk, Fig. 1, is shaped into a cap or shell of the form represented in elevation and section in Fig. 2. The sides of the said shell or cap may be made slightly thinner than the closed end of the cap. The cap, Fig. 2, is next shaped by means of a pair of press or stamp tools, hereinafter described, so as to form, nearly across the inner side of the head or closed end of the cap, a ridge or projection, and on the outer side of the said head or end a V-shaped notch or depression, for the purposes hereinafter explained. The cap, after it has been subjected to the treatment last described, has the figure represented in cross-section and plan of upper side in Fig. 3, the cross-sections being taken at right angles to one another. In the said Fig. 3 the ridge or projection on the inner side of the head of the cap *a* is marked *b*, and the notch or depression on the outer side of the said end of the cap is marked *c*. The ridge or projection *b* fits in the nick in the head of the screw, and the notch or depression *c* serves as a guide for the formation of the nick in the finished screw. By an examination of Fig. 3 it will be seen that the hollow or depression *c* does not extend quite across the cap *a*, the metal at the edges of the said cap being left nearly of the original shape. The tools by which the fashioning of the ridge *b* and depression *c* is effected are shown in section combined, and in action in Fig. 4 and separately in Fig. 5. In the said Figs. 4 and 5, *d* is the lower tool fixed on the bed of the press or stamp, and *e* is the punch or upper tool fixed to the plunger or ram of the press or stamp. The acting end of the punch *e* is cylindrical, the under side of the said acting end having a cross-groove, *e*², in it. The hole *d*² in the lower tool *d* is cylindrical, and the central peg *f* of the said lower tool has on its upper face an angular projection, *g*. The cap *a*, Fig. 2, being placed with its closed end downward in the lower tool *d* and supported by the central peg *f*, the punch or upper tool *e* is made to descend upon it.

By the operation of the said tools, as illustrated in Fig. 4, the ridge *b* and notch or hollow *c* are fashioned in the head of the cap. The brass cap, Fig. 3, is now ready to be compressed, fixed, and shaped upon the head of

the screw which is to be covered. The said head of the screw has the form represented in Fig. 6—that is, it has a smaller head and the nick is both deeper and broader than usual.

The tools by which the compressing, fixing, and shaping of the brass cap, Fig. 3, upon the head of the screw are effected are represented in Figs. 7, 8, and 9, Fig. 7 representing the said tools in vertical section, and exhibiting the positions of the parts before the descent of the punch or upper tool; Fig. 8 representing the same after the punch has descended and closed or compressed, fixed, and shaped the brass cap upon the head of the screw, and Fig. 9 representing the lower tool separately.

The punch or upper tool, which is attached to the plunger of the press or stamp, is marked *h*, and the lower tool, which is fixed on the bed of the press or stamp, is marked *i*. In the lower tool *i* is an axial hole, the upper and lower parts *l k* of which are of different diameters, the lower part *k* having a size proper to receive the stem of the screw, which loosely fits it, and the upper part *l* having a size proper to receive the shaped cap, Fig. 3, and the punch *h*. The upper and lower parts *l k* of the axial hole in the lower tool *i* pass into one another by a conical shoulder, *m*, having the same inclination as the sides of the head of the screw to be covered, but of greater depth, as represented. The upper tool or punch *h* is cylindrical, and fits accurately the upper cylindrical hole *l* in the lower tool. At the bottom of the cylindrical hole *k* is a spring seat or support, on which the point of the screw *n* is supported when placed in the lower tool.

In using the tools, Figs. 7, 8, and 9, the screw *n*, Fig. 6, is placed and supported in the lower die *i*, so that its head is above the conical shoulder *m*. The shaped cap *a*, Fig. 3, is next placed mouth downward in the lower die, the ridge *b* of the said cap being fitted into the nick *n*² in the head of the screw, as represented in Fig. 7. The parts having the relative positions represented in the said Fig. 7, the cylindrical punch *h* is made to descend and enter the lower tool *i*.

By the operation of the said punch *h* the screw *n* and cap *a* are carried down, and the said cap is compressed with great force between the punch *h* and the conical shoulder *m* of the lower die or tool *i*, the metal at the mouth of the cap being gathered in and compressed upon and fixed to the conical under side of the head of the screw, while the closed end of the cap is compressed upon the top of the head of the screw, and the ridge *b* forced into and made nearly to fill up the nick *n*² in the said head, as illustrated in Fig. 8. The head of the screw is thus covered with a covering of brass, and the said covering is ready to be finished by being turned and nicked.

In effecting the nicking of the covered brass head care must be taken that the nick cut in the said brass covering is symmetrical with the nick in the head of the iron screw, the

notch or hollow *e* left in the brass covering serving as a guide for accurately nicking the said brass covering.

Fig. 10 represents, partly in section, a finished screw, the head of which has been covered with brass, and the head turned and nicked, as before described.

When the shanks of the screws are to be protected by galvanizing or tinning or other protecting process, the galvanizing or tinning process is performed after the headed screw is pointed and wormed, and before its head is nicked and turned, the zinc or tin being removed from the head by the turning process.

The screw may be pointed, wormed, and galvanized before the brass cap is fixed on the head.

In order to facilitate the placing of the screw or screw-blank, Fig. 6, and brass cap, Fig. 3, in the lower die or tool *i*, the ridge *b* in the said cap may be made to fit tightly in the nick *n*² in the screw-blank. The cap is then driven on the head by a hammer. It is thereby held with sufficient firmness in the proper position until fixed by the pressure of the descending punch *h*.

As the cylindrical part of the cap, on being fixed on the screw-head, is shortened and thickened, I make the cylindrical part longer and thinner than the finished brass covering of the under side of the screw-head.

Although I prefer to provide the cap, Fig. 2, with a ridge, *b*, and hollow *e*, as represented in Fig. 3, before the said cap is placed upon the head of the screw to be covered, yet a cap of the shape represented in Fig. 2 may be employed in place of the said cap, Fig. 3. In this case I provide the acting end or face of the punch *h* with a cross projecting rib, and the nick *n*² in the screw, Fig. 6, is so placed in the die *i* that it is exactly under the rib described on the punch *h*.

By the descent of the punch its cross-rib forces the brass cap into the nick of the screw-head, and also leaves a line or mark on the cap where the nick has subsequently to be made in the said cap.

Instead of employing a sheet-metal cap, as before described, a brass covering may be cast upon the head of the screw, and the covered head be afterward operated upon by means of the tools, Figs. 7, 8, and 9, for the purpose of compressing and more firmly fixing the cast

covering upon the head, and perfecting the general figure of the said covering.

The cast covering fixed upon the head of the screw is finished by turning and nicking, as described with respect to a sheet-brass cap or covering.

Instead of a covering of brass, a covering of copper or other ductile metal or alloy may be employed.

The tools hereinbefore described, and illustrated in the accompanying drawings, may be worked in presses or stamps of the ordinary kind; or the said tools may be worked in special machines made for the purpose, or such as are commonly used for shaping or fashioning metals.

The heads of all kinds of countersunk screws, as well as screws having hemispherical or other shaped heads, may be covered with brass or other metal, according to my invention.

Having now described the nature of my invention and the manner in which the same is to be performed, I wish it to be understood that I do not limit myself to the precise details herein described and illustrated, as the same may be varied without departing from the nature of my invention; but

I claim as my invention of improvements in the manufacture of screws, and in machinery or apparatus to be employed in the said manufacture—

1. The method herein described of providing the heads of iron screws with a cover of brass or other ductile metal or alloy, the same consisting in applying to the screw-head, preliminarily prepared as herein specified, a cap or covering of ductile metal or alloy, which is first compressed, fixed, and shaped on said head by pressure or stamping in a die, and subsequently finished and nicked, substantially in the manner herein set forth.

2. The series of tools or apparatus, hereinbefore described, and illustrated in Figs. 4, 5, 7, 8, and 9 of the accompanying drawings, to be used in fashioning the brass or other metallic cap, and for compressing, fixing, and shaping the brass or other cap or covering upon the head of the screw.

GEORGE HOOKHAM. [L. S.]

Witnesses:

RICHARD SKERRETT,

HENRY SKERRETT,

37 Temple Street, Birmingham.