

H. WINN.
Lock for Doors, &c.

No. 161,315:

Patented March 23, 1875.

Fig. 1.

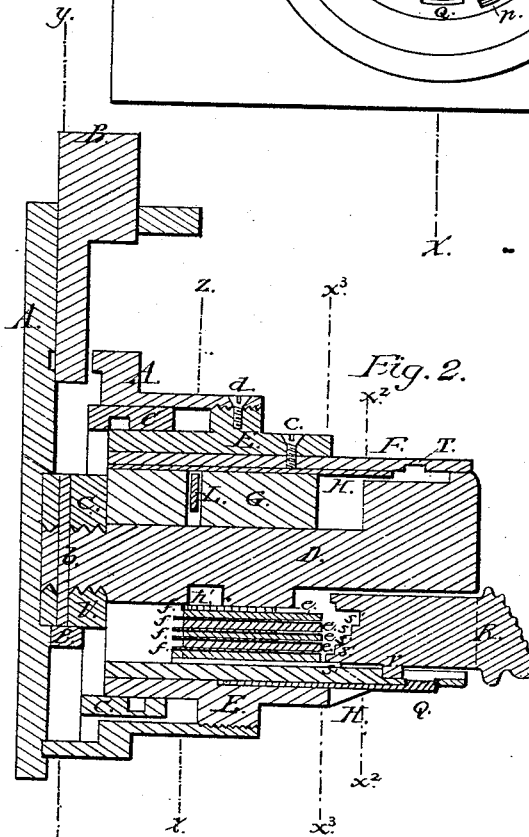
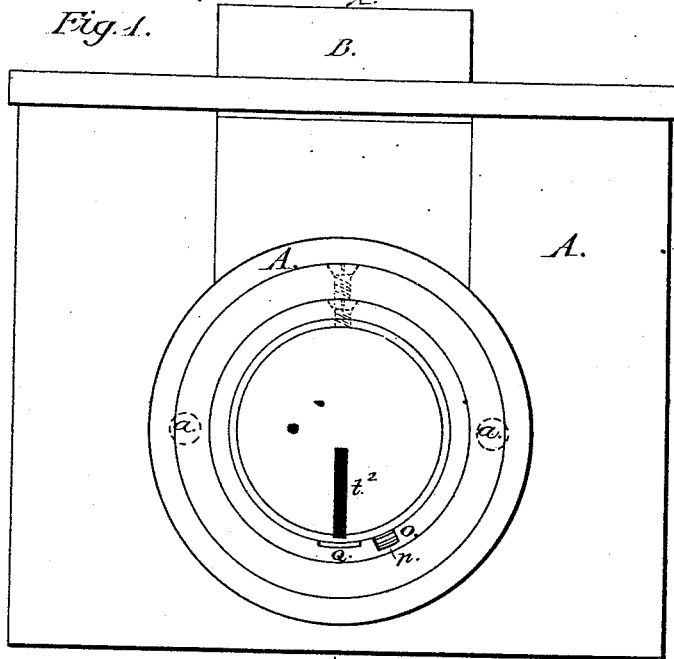
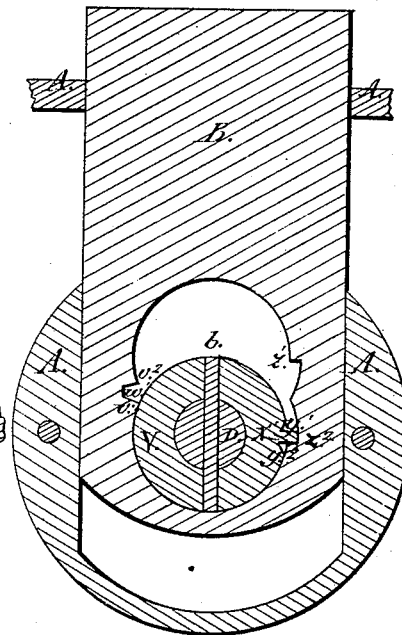

Fig. 2.

Fig. 3.



Witnesses:

J. R. Pratt
H. J. Sheppardson

Inventor:

Henry Winn

H. WINN.
Lock for Doors, &c.

No. 161,315.

Patented March 23, 1875.

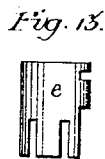
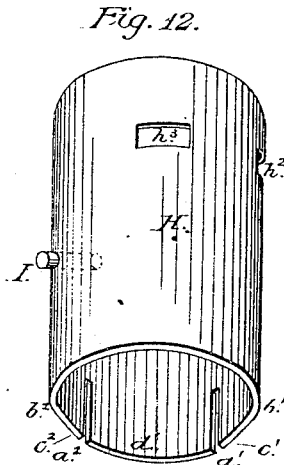
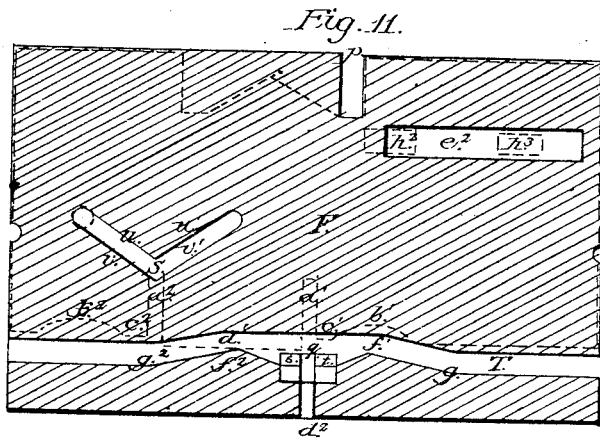
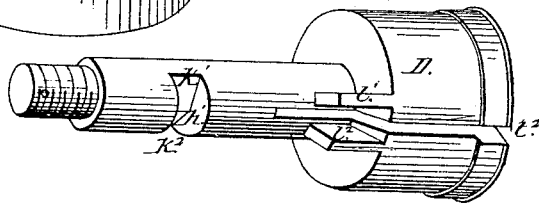
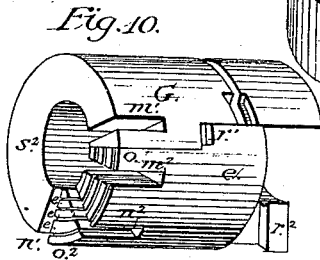
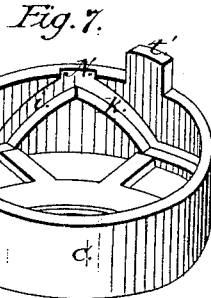
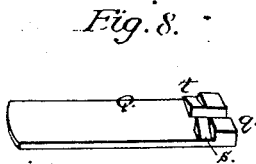
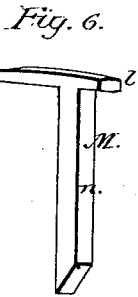
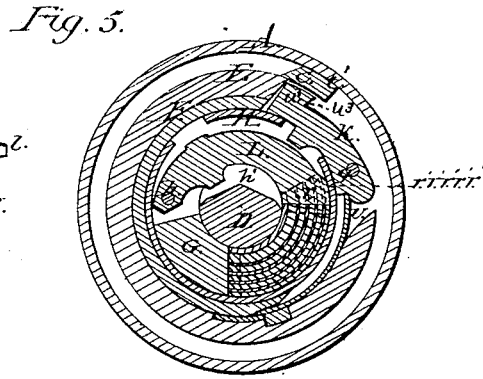
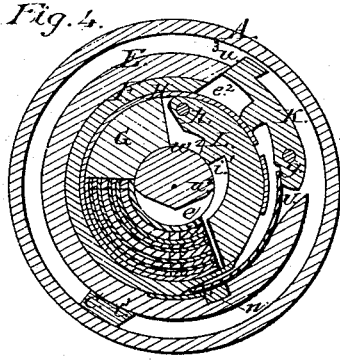

Witnesses:

P. R. Pratt
H. S. Shepardson

Inventor:

Henry Winn

UNITED STATES PATENT OFFICE.

HENRY WINN, OF SHELburnE, MASSACHUSETTS.

IMPROVEMENT IN LOCKS FOR DOORS, &c.

Specification forming part of Letters Patent No. 161,315, dated March 23, 1875; application filed July 30, 1874.

CASE F.

To all whom it may concern:

Be it known that I, HENRY WINN, of Shelburne, in the county of Franklin and State of Massachusetts, have made certain new and useful Improvements in Locks, whereof the following is a specification, reference being had to the accompanying drawings, in which—

Figure 1 represents a front view of the lock in the locked position. Fig. 2 shows a vertical section thereof, taken through the line *xx* of Fig. 1. Fig. 3 shows a vertical section thereof, taken through the line *yy* of Fig. 2. Fig. 4 shows a vertical section thereof, taken through the line *zz* of Fig. 2. Fig. 5 shows a vertical section thereof, taken through the same line, and showing the same parts as Fig. 4, in a position assumed by them in the unlocking process. Fig. 6 shows the bar used to restore the tumblers. Fig. 7 shows the cylindrical return-cap, which forms part of the rotating shaft. Fig. 8 shows a spring used as a key-guide and stop. Fig. 9 shows the shaft removed from its return-cap. Fig. 10 shows the partially-rotating shell containing the tumblers and friction-plates or furrings. Fig. 11 shows a plane projection of the interior surface of the inner stationary shell, and thereon in dotted lines a plane projection of the exterior surface of the shell seen in Fig. 12, in its position thereon when the lock is locked; also, the head of the spring, Fig. 8. Fig. 12 shows the cylindrical shell for inclosing the partly-rotating shell, Fig. 10, with the pin used to secure them together and actuate the same. Fig. 13 shows a tumbler.

A is the lock-case, composed of two parts, fastened together by the screws *aa*. B is the bolt. C is the return-cap, which is attached to the rotating shaft D, being secured thereon and pinned by the pin *b*. E and F are stationary shells, fastened together by the screw *c*, and fastened to the case by the screw *d*. G is the partly-rotating shell containing the sliding tumblers *eeee* and the furrings *ffff*. H is a cylindrical shell, inclosing the shell G, being fastened thereto by the actuating-pin I, which, passing through the shell H, is embedded in the shell G. L is the fence, pivoted on the pin *h* to the shell G, and partaking of the motion thereof. K is a dog, pivoted on the

pin *g* to the stationary shell E. M is the restoring-bar, having a projection, *l*, which moves in the inclined grooves *i* and *k* of the groove N in the return-cap C, and is projected backward and forward by the rotation of the cap C, while the arm *m* thereof restores the tumblers in its forward motion, being held in position on their curved ends by the shank *n* working in a groove *o* in the outer stationary shell E, and by the slot *p* in the stationary shell F. Q is the spring key-guide, having a groove, *q*, through which passes the projection *r* on the key R, and having two inclined planes, *s* and *t*, whereby said projection *r*, in completing the rotation of the key, forces down the spring Q, until it can enter the groove *q*, when the spring Q springs up and acts as a stop and guide therefor. Said spring Q is located under the key-entrance *d*², and in line therewith, and is secured by insertion in a groove fitted to receive it in shell E between the shells E and F, and by the projection of its head into shell F. S is a V-shaped slot in the stationary shell F, having four inclined surfaces, *uu*¹ and *vv*¹, whereon the pin I bears, and by a partial rotation of the shell H drives back and forward the said shell H, and certain parts therein. On the end of shell H is a projection, *d*¹, which acts as a stop to the key projection *r* when its rotation is completed; also, two slots, *a*¹ and *a*², into one of which said projection *r* enters to rotate said shell either way; also, two curved surfaces, *b*¹ and *b*², ending at the points *c*¹ and *c*², which points project over the groove T, and aid in guiding the key projection *r*.

At the key-entrance *d*² in shell F the groove T is wider than elsewhere by the amount that the point *c*¹ of the shell H projects over the same, excepting as it is narrowed by the inclined part *t* of the head of the spring Q, which compels the projection *r* on the key to enter the slot *a*¹ or *a*², and rotate the shell H. Said groove T contracts each way from the key-entrance *d*² until it reaches the points *f*¹ *f*² at an angular distance measured on the cylindrical shell F from the key-entrance *d*² equal to half the angular distance of the separate ends of the equal planes *uu*¹ of the slot S. It then advances the same angular distance to *g*¹ and

g^2 , inclining toward the front by the amount of the projection of shell H over groove T at c^1 . The shaft D has a depression, h^1 , into which the projection i^1 on fence L falls, and two inclined surfaces, $k^1 k^2$, therein, by which said fence L is lifted out thereof when shaft D rotates and fence L does not; also, two projections, $l^1 l^2$, corresponding in shape and distance apart to each of two sets of the depressions $m^1 m^2$ and $n^1 n^2$. The depressions m^1 and n^1 are in shell G, and the depressions m^2 and n^2 are in the tumblers. When the lock is locked, the outer end surfaces of the tumblers $e e e e e$, on a line drawn from o^1 to the center of the lock, are opposite the key-hole t^2 , and those on a similar line drawn from o^2 when unlocked. Said tumblers have fence-notches $r^1 r^1 r^1 r^1 r^1$, having distances from the plane of fence L equal to the length of their corresponding key-bits $s^1 s^1 s^1 s^1 s^1$. The fence L and dog K are projected inward on their pivots by the spring U, and when the fence-notches are properly adjusted fence L enters the same, and the head w^3 of dog K falls inward enough to admit the passage over it of the projection t^1 on the return-cap C. The bolt B is firmly set in a bolt-guide formed by the case A, and is provided with the curved projections $v^1 v^2$ and depression w^1 between the same, while into the hub V of the return-cap C is set a tooth, X', between two depressions, $y^1 y^2$, all arranged as shown in Fig. 3, so that in operating the bolt by rotating the shaft D and cap C, the tooth X' enters the depression w^1 , and the projections v^1 and v^2 enter the depressions y^1 and y^2 , and are carried above or below the horizontal center of the periphery of the hub V as the bolt is thrown or retracted, the projection v^1 resting on said periphery to hold out, and the projection v^2 below said center to hold in, said bolt. In the opposite side of the bolt are cut two stops, z^1 and z^2 , arranged relatively to the tooth X' as shown, so that it impinges on z^2 when the key R in its rotation reaches its point of exit after locking, and on z^1 after unlocking, thereby, through the shaft D, making a stop for said key at said point. An opening, e^2 , through the stationary shells E and F is made to contain the dog K, and the openings $h^2 h^3$ are made in the shell H, to admit the contact of a projection on the dog K with the fence L, through opening h^2 in unlocking, and h^3 in locking. The inward movement of the tumblers is limited by the projection r^2 on shell G. The smaller part of the shaft D passes through the center of the cylinder formed by the shell G, tumblers, and furrings.

The unlocking operation is as follows: The key is inserted, and the projection r enters the groove g in the spring Q. The sides of said groove prevent said projection from rotating without first passing through the same and into slot a^1 in shell H. Said projection r then rotates the shell H, and all the parts contained therein, except the shaft D—to wit, the shell G and the tumblers $e e e e e$, the furrings $f f f f f$, and the fence L—and the pin I, bearing

against the inclined surface u of slot S, causes the shell H to advance, thereby drawing with it said parts, rotated as aforesaid, and projecting the projections $l^2 l^1$ into the depressions $m^1 m^2$, and the ends of the tumblers $e e e e e$ between said depressions against the key-bits $s^1 s^1 s^1 s^1 s^1$, and setting their notches $r^1 r^1 r^1 r^1 r^1$ in line under the fence L, which setting is completed when the said pin I reaches the inclined surface v^1 . Pin I is then driven backward, thereby carrying back shell H and the parts therein rotated, as aforesaid, including the tumblers set as described, while the projection r , reacting against the groove T, partially retracts the key, until said projection r reaches the point g^1 , where it is entirely withdrawn from the slot a^1 , and the projections $l^1 l^2$ from the depressions $m^2 m^1$, thereby releasing shell H and the parts therein rotated, as aforesaid, from connection with the key and shaft D. At the same time the pin I reaches the end of the slot S, and thereby shell H and the parts contained therein, rotated as aforesaid, are brought to a full stop, and are held stationary by the reaction of the projections $l^1 l^2$ in the continued rotation of shaft D upon the face s^2 of the shell G, combined with the reaction of the pin I against the inclined surface u^1 and the end of slot S, where the pin I is held firmly until the projections $l^1 l^2$ reach the depressions $n^2 n^1$, which is at the key's point of exit. At the beginning of the operation the projection l of the restoring-bar M is at the junction of grooves i and k in the cap C, and said restoring-bar M is driven back, as described, by groove k , so that its arm m will not impinge against the tumblers until the proper time for their restoration. The part of groove N which does not move the restoring-bar M reaches it when projection r reaches g^1 , and retains it until said projection reaches g^2 , when groove i drives it forward, and, meeting the tumblers, it restores them. The position assumed by shell H is such that the fence L therein is in contact with dog K through the opening h^2 . The rotation of shaft D being continued while the fence is at rest, depression h^1 is brought under projection i^1 , which drops into the same, allowing projection t^1 to pass over the head w^3 of the dog K, as described, and complete its revolution, while the part V of the return-cap C retracts and locks in the bolt, as described. When the projection t^1 has passed over the head w^3 of the dog K, as described, the inclined surface k^1 of the shaft D lifts the fence out of the notches $r^1 r^1 r^1 r^1 r^1$, and, the rotation continuing, the projection r is forced upon the inclined plane s of the spring Q by the curved surface b^2 until it enters the slot g , and at the same time, impinging on the part d^1 at the slot a^2 , now at the key-hole, it is guided out.

In case the tumbler-notches are not correctly set the fence will not enter the same, the head w^3 cannot be projected inward by the spring, and the projection t^1 of the return cap

will strike the same, and prevent the rotation of the shaft D and the operation of the lock.

The parts of the projection t^1 and of the head w^3 of the dog which impinge when the tumblers are not set correctly are two inclined planes, arranged as shown, so that, in such case, the part t^1 lifts away the dog K from contact with the fence L, instead of pressing the same inward, thereby preventing measurement of the variations of the tumblers through the fence.

The locking operation is by a reverse rotation of the key and shaft D, and is sufficiently obvious from the above description, the tumblers being brought against the key-bits in their end surfaces on the line o^2 . The tumblers, furrings, and shell G are in the position shown in Fig. 5 at the beginning of the locking process, (excepting that the tumblers are restored,) and in the position shown in Fig. 4 at the beginning of the unlocking process, alternating from one position to the other through said processes. It will be seen, Fig. 4, that the fence rests on the periphery of shaft D, and when thereon it is held away from touching the tumblers. Nor can it be made to touch them when they are accessible through the key-hole t^2 ; for when the shaft D and the fence rotate in common, its projection v^1 cannot change its position on said periphery; and if the shaft D and key-hole t^2 are rotated one way, while the fence (and consequently the tumblers and remaining parts in shell G) are stationary, the key-hole t^2 passes instantly away from the surfaces of the tumblers, and the inner end thereof comes on the surface s^2 of shell G, which then lies directly intervening between the key-hole and the ends of the tumblers, which take the key-setting, and the projection l^1 or l^2 extends quite to said surface s^2 , preventing the introduction of a crooked instrument to feel back upon the tumblers' ends around the surface s^2 of shell G, said inner end coming on the surface s^2 , as aforesaid, before the part w^2 of said periphery passes under the projection v^1 , and remaining thereon while the said projection is in depression h^1 . On the other hand, if the shaft D and key-hole t^2 are rotated the other way, in the same case, over the entire ends of the tumblers, the inner end of said key-hole still passes on the surface s^2 , and the projection l^1 or l^2 extends to said surface, and the tumblers are protected from access, as before, before the part w^2 of said periphery is rotated from under the projection v^1 , and while said projection is in depression h^1 .

Locks are picked, by the feeling process, by the sensation communicated through the tumblers when their notches pass or reach a fence that bears upon them. This is obviated in this lock by preventing the fence from bearing upon the tumblers, as described, when they are accessible, and by cutting off all communication with them when the fence can bear upon them.

The projections l^1 l^2 on shaft D constitute

an extension of the key-hole t^2 , each projection being an extension of one side thereof. The enlargement of width of said key-hole between said parts is to admit a more substantial portion of shell G and the tumblers, and aid projection r on the key in rotating shell G; but the effect would be obtained if the key-hole were of uniform width through said parts and shaft D, if the tumblers had narrower front ends at o^1 and o^2 , of width suitable to enter the same, said ends still aiding in rotating shell G by reacting in the key-hole; and said projection r would rotate shell G unaided, although the supplementary aid of parts l^1 l^2 is needed to prevent severe wear on said projection, which also limits the setting of the tumblers.

When the term "longitudinal portion of the lock" is mentioned, it refers to the portion of the lock parallel to the axis of the rotating shaft, and the time when the fence is projected into its notches, or bears against the sides of the tumblers containing them in the effort to enter said notches if not set correctly to admit it—to wit, the time when said notches may be detected by the feeling process of picking—is designated as the time when the fence "tries" the tumblers; and to "set" the tumblers refers to their adjustment, so that their notches are in proper position to admit the fence when it tries them. Said extension l^1 or l^2 reaches into the longitudinal portion of the lock, in which the ends of the tumblers take their setting. While being set said ends are located both in said longitudinal portion, and in the same plane as the key-hole, wherefore they are easily accessible to be impressed by the key therein; but when the fence tries the tumblers, said ends are not so located, the extension l^1 or l^2 becoming a guard to protect said ends from access, as aforesaid.

Collision with said tumbler ends, (which take the key-setting,) when the extension rotates and they do not, is avoided by their withdrawal from said longitudinal portion before the fence tries the tumblers, and their common rotation while being set and withdrawn. But so far as the protection of the tumbler ends from accessibility is concerned, the extension part l^1 or l^2 , for instance, instead of the projection and withdrawal of the tumblers, might equally well be projected forward and back into said longitudinal portion, by being constructed in a separate piece from shaft D, and having a bearing in said shaft, limiting it to the motion longitudinal therewith, and having a pin working on inclined surfaces in shell F; or, if enlarged, having inclined surfaces working on a pin in shell F, suitable notching being made in the key to prevent collision with the pin, said pin and surfaces being arranged relatively to each other in position to project said extension forward into said longitudinal portion after the tumblers ceased to rotate and before the fence tried them, and withdraw it therefrom in season to prevent its collision with the tumblers

in completing the revolution, the mechanism operating said extension being substantially similar to that used to project and retract shell G.

In this case, if the tumblers were not retracted, the extension would perform the function now performed by the outer end of shell G, of intervening between the key-hole and the tumblers when the fence tries them.

If the tumblers are stationary at all times, and the key-bits rotate over them, said bits will leave marks on the tumbler ends, bearing a fixed relation to the lengths of the bits, from which said lengths may be ascertained, besides causing wear on said bits. This is obviated by the rotation of the tumblers in shell G, in common with the key, while they are being set, while they have, afterward, the advantages of stationary tumblers.

The longitudinal portion of this lock, heretofore referred to, lies between vertical sections through the lines $x^2 x^2$ and $x^3 x^3$ of Fig. 2.

When the fence tries the tumblers there is a certain longitudinal portion of the lock into which their front ends project more or less, according as they have been set by longer or shorter bits of the key, which portion extends lengthwise from the front end of a tumbler set by the longest key-bit to the front end of a tumbler set by the shortest key-bit possible in the lock's construction. Usually nothing intervenes between the inner end of the key-hole and the ends of the tumblers which take the key-setting, and are located in said portion of the lock. But in this lock the front end of shell G, having the surface s^2 , including the portions of said shell between depressions m^1 and n^1 and the tumblers, is located in position to intervene between the key-hole and said ends at the time when the fence tries the tumblers, forming a solid metallic cut-off to prevent access to said ends by picking-tools.

A cut-off intervening as aforesaid may have been used with a key of which the bitted portion remained stationary with the tumblers, and was detached from or jointed to the remainder or shank of the key, which continued to rotate the shaft to operate the lock; but a detachable or jointed key of this nature is costly and clumsy, and is really composed of two separate instruments, unlike key R, of which all parts rotate together. Secondly, a cut-off has been used in locks wherein the key entered the key-hole to set the tumblers, while other mechanism was used to operate the lock, and drive a cut-off over the inner end of the key-hole before the fence tried the tumblers, the key being withdrawn or left in the key-hole (usually stationary) with the tumblers, and covered by the cut-off, while the lock was operated by a separate mechanism, inconvenient of use, in which the key was not required. In this case the key, acting in the key-hole of the rotating shaft, first sets the tumblers, and then the

entire key, continuing the rotation, operates the lock, while the cut-off intervenes, as aforesaid, at all times when the fence can try the tumblers.

The inventor is not aware of the use of any cut-off with tumblers having a motion substantially rectilinear with the key's axis, to give them their setting, except as aforesaid. Furthermore, the cut-off intervenes, as aforesaid, because it is stationary relative to the rotation of shaft D, after the tumblers are set, and before the fence tries them, and is located as shown, whereby the key-hole in said shaft is rotated into such position relative thereto that when the fence tries the tumblers the cut-off intervenes, as aforesaid. No cut-off of this construction has been used with tumblers of any class, so far as the inventor is aware, except as aforesaid.

By the term "tumblers" in claims 9, 10, and 11, any pieces receiving the setting of the key from the key-bits are included, if at the time when the fence tries the parts of the tumblers having the notches its trial thereof may be felt through them; for the purpose of the cut-off is to prevent the communication of sensation from the fence acting on a fence-notch or tumbler side, which would pass through any number of intermediate pieces having such connection with the tumblers as to be limited or hindered in their motion by the friction or impact of the fence on the sides or notches of one or more of the tumblers when said fence tries them. A cut-off must be free from such connection. For instance, if a tumbler, e , were divided in two parts in a line parallel to its length, between notch r^1 and slots $m^2 n^2$, the operation of the lock would be similar, and its front end, in the line o^1 or o^2 described, would convey sensation, as described, and require protection of the cut-off, though called an intermediate piece.

By the term "rotating shaft" in said claims, the inventor refers also to rotating shells, it being immaterial, relative to the action of the cut-off, whether it is made in form to inclose the tumblers or not. If the bitted part of the key (which rotates with shaft D) were in the same longitudinal portion of the lock with the front ends of the tumblers when the cut-off is required to intervene, as described, it would collide with the cut-off in rotating. This would require the key's withdrawal before the cut-off intervenes, at great inconvenience to the operator. To avoid this, and for other purposes obvious and described, I carry forward the tumblers against the key-bits, and withdraw them from the occupation of a longitudinal portion of the lock, common with the key-bits, in a shell projected back and forth by a hardened-steel pin or projection on said shell, acting against two or more inclined surfaces in a stationary shell, although the pin I may be in the stationary shell, with the inclined surfaces located in shells H and G, or in shell H alone if attached to shell G, with

the same effect if the inclination of said inclined surfaces is reversed. And the same device may be used when the shell containing the tumblers does not rotate, if said shell is combined with a rotating shell, and the pin or projection described is in one shell, arranged to act upon the inclined surfaces, as described in the other shell.

What I claim as my invention, and for which I pray Letters Patent, is—

1. The combination of the tumblers and key with a rotating shell and a non-rotating shell, when one of said shells contains the tumblers, and is carried backward and forward by the reaction of a pin or projection on one of said shells against two or more inclined surfaces on the other shell, carrying the tumblers toward and from the bits of a key, as described.
2. A shell containing tumblers, combined with a part having a key-hole, giving access to said tumblers, when said shell and tumblers partake of the rotation of the said part carrying the key-hole during the time while the tumblers are being set, but do not partake thereof at the time when the fence is projected against one or more of said tumblers, or into the notches thereof, to admit of the operation of the lock, for the purposes described.
3. The arrangement of a shaft, having a key-hole and a depression to admit the fence, relatively to said key-hole, fence, and the end surface or surfaces of a shell or other part, and of a set of tumblers, which partake of the rotation of the key through a portion thereof, whereby said depression is not brought under said fence to admit the same, except at that point of the rotation of the shaft carrying the key-hole, when said key-hole is opposite the surface of the shell or other part, and not opposite the surface or surfaces of the tumblers.
4. One or more of the projections $v^1 v^2$ on a shaft, D, combined with one or more of the depressions $y^1 y^2$ in shell G, and $m^2 n^2$ in the tumblers, for the purposes described.
5. The spring Q, combined with the groove g and the inclined surfaces $t s$, arranged and operating as described.
6. A shell partaking of the rotation of the key through a part, but not through the whole, of the same, having the slots $a^1 a^2$ combined

with the key or a projection thereon, for the rotation of said shell.

7. The hub V of the return-cap C, combined with the bolt, and a guide therefor, the projections $v^1 v^2$, the depressions $y^1 y^2$, the notch w , and tooth X', and one or more stops $z^1 z^2$, with the arrangement thereof, relatively to the position of the tooth X' in its rotation, as described, whereby the tooth X' strikes one of said stops when the key reaches its point of exit.

8. A fence and a key combined with a rotating shaft having a key-hole, which has one or more of its sides extended into the longitudinal portion of the lock, in which the ends of the tumblers take their setting from the key, and combined with a system of tumblers which have said ends located in said longitudinal portion, and in the same plane as the key-hole, at the time when they take their setting, but not at the time when the fence enters the tumbler-notches, or impinges on the sides of the tumblers to enter the same.

9. A fence and a system of tumblers having a motion substantially rectilinear with the axis of the key, a key of which the bitted portion rotates with the rotating shaft, combined with a rotating shaft having a key-hole, and with a cut-off located in position to intervene between the key-hole and the ends of the tumblers, which are set by the key at the time when the fence enters the notches of said tumblers, or impinges upon the sides of said tumblers, to enter said notches.

10. A system of tumblers and a fence, combined with a rotating shaft having a key-hole, and with a key of which the bitted portion rotates with said shaft, and with a cut-off which is stationary before the time when the fence enters the notches of the tumblers, or impinges on the sides of the tumblers, to enter said notches, whereby at said time the key-hole is rotated into such position relative to said cut-off that said cut-off intervenes between the key-hole and the ends of said tumblers, which take the setting thereof from the key.

HENRY WINN.

Executed in presence of—
F. R. PRATT,
EDWIN BAKER.