

E. WOOD-
Puddling-Furnace.

No. 161,317.

Patented March 23, 1875.

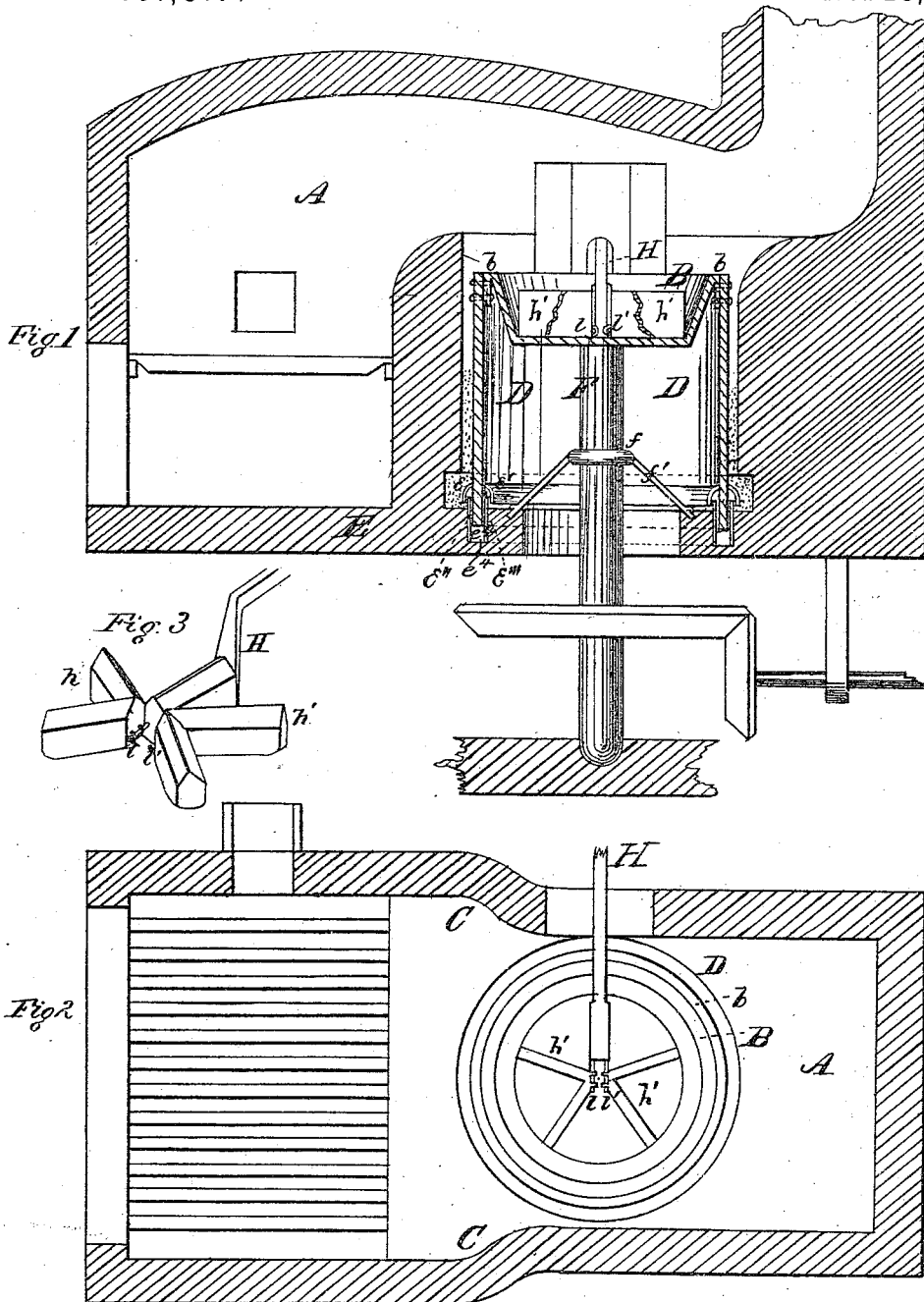

161,317. PUDDLING-FURNACES. E. Wood, Pittsburg, Pa., assignor of one-half his right to J. H. Legge, same place. [Filed Nov. 13, 1874.]

Brief.—The cylinder is joined to the circular hearth, which revolves with it. The puddling-tool is kept stationary in the revolving hearth. The cylinder forms a sand and water joint with the walls of the furnace.

1. The balling tool, consisting of the handle H, with the diverging wings h' pivoted or hinged thereon, substantially as described and shown.
2. The combination, with the cylinder D and the furnace-wall surrounding the same, of the interenging annular sand-joint, substantially as described.
3. The cylinder D, in combination with the rotary basin B and the water-trough e', said trough being formed in the base of the furnace, substantially as shown and described.
4. The guard-flanges e'', in combination with the cylinder D and trough e', substantially as and for the purposes specified.

Enoch Wood, Inventor

Samuel Power & Wm. T. Tigh Attorneys

November 13, 1874.

To all whom it may concern:

Be it known that I, ENOCH WOOD, of Pittsburg, in the county of Allegheny and State of Pennsylvania, have invented certain new and useful Improvements in Puddling and Balling Furnaces; and I do hereby declare the following to be a full, clear, and exact description of the invention, such as will enable others skilled in the art to which it pertains to make and use it, reference being had to the accompanying drawings, which form part of this specification, in which—

Figure 1 is a vertical section of furnace. Fig. 2 is a plan view. Fig. 3 is a perspective view of the balling-tool.

My invention relates to that class of puddling and balling furnaces wherein the metal bed or basin is made to revolve, and, by the use of a stationary balling-tool the metal, when properly worked up, is balled all at once by one single operation; and my invention consists, first, in the novel construction of the balling-tool; and, secondly, in the novel means for excluding air from the rotary basin, all as hereinafter specifically described and claimed.

For these purposes I construct a puddling and balling furnace as follows: I change the shape of the usual reverberatory furnace by narrowing its bore at or about the circular metal basin, forming a shoulder or offset in the furnace, whose projection culminates at about the center of the metal basin. This, by directing the heat into the basin and upon the metal, hastens and facilitates the operation of puddling. To the lipped or flanged edge of the circular metal basin I attach a deep cylindrical flange, extending from the lip on the basin down to the foundation-plate, and into an annular groove in the same, which is kept filled with sand or water by hoppers or pipes adapted for the purpose. This cylindrical flange, which is vertical, is provided near the bottom with downwardly-curved annular flanges inside and outside, and, respectively, overlapping vertical flanges rising from the two sides of the annular groove in the foundation-plate. The purpose of these flanges is to exclude slag, cinders, or any foreign substance from entering the groove, and thereby clogging the same. The cylindrical flange being fastened air-tight at

its top to the lip of the metal basin, and revolving with it, and the sand in the groove preventing access of air, the metal in process of puddling is absolutely secure against danger arising from the admission of atmospheric air or vapors, which might injure the quality of the metal, while the air has free ingress to the exterior surface of the metal basin for cooling purposes. The cylindrical flange serves, also, as a partial support for the metal basin. The latter is otherwise supported on a central vertical shaft, held in place by a ring supported by rods passing laterally and downwardly into the foundation-plate. This shaft rests in a step or socket below the foundation-plate, and is fixed to, and revolves with, a beveled wheel which meshes with a pinion-wheel fixed to a horizontal shaft, the whole so arranged that, by turning the latter, the vertical shaft revolves, and thus rotates the furnace-bed or metal basin.

In the ordinary sliding door I construct another slide for the admission of the balling-tool. The metal is puddled by the stationary flail-shaped rabble, and, when ready for balling, this is withdrawn, and the balling-tool inserted through the slide. This tool consists of a rod bent at right angles twice, thus continuing in parallel lines. The interior end of the rod is enlarged into a heavy plate or wing, so constructed that when lowered into the basin it will extend from the circumference to the center of the same. To the end of this are attached one, two, or more pintles, upon which similar wings in pairs, rigidly fixed, are loosely hung in such a manner relatively that, when spread out in the basin, they form radiuses, and divide the basin into three, five, or more equal segments, and are also so hung that when the tool is lifted from the basin the wings or enlargements fall together in a compact form, easily removable through the door-slide. When the metal is puddled this tool is inserted and lowered into the mass of molten metal, cuts it into three, five, or more equal portions, each of which then, by the rotation of the basin, is kept rolling and tumbling about until firmly balled, when they are ready for the squeezers or rolls.

Reference being had to the accompanying

drawings, A represent a reverberatory furnace containing the rotating basin B. At C are shown the shoulders or offsets in the side walls of the furnace. *bb* designate the lip or flange on the basin B. D is the cylindrical vertical flange, extending down into the foundation-plate E, and having near its bottom downwardly-curved annular flanges *e e'*, overlapping the vertical flanges *e'' e'''* lining the trough *e^t* in the foundation-plate. The central vertical shaft F is attached to the metal basin B, and rests in a socket in the foundation, being also supported by a ring, *f*, braced by rods *f'*, which are constructed with a shoulder to permit them to enter only a proper distance into the foundation-plate E. H is the rod or handle of the balling-tool, furnished with furcated pintles *ll'*, upon which hinge the wings *h* in pairs. This tool passes through the slide in the door, and is removed in the same manner.

Having thus fully described my invention, I claim—

1. The balling tool, consisting of the handle H, with the diverging wings *h'* pivoted or hinged thereon, substantially as described and shown.

2. The combination, with the cylinder D and the furnace-wall surrounding the same, of the intervening annular sand-joint, substantially as described.

3. The cylinder D, in combination with the rotary basin B and the water-trough *e^t*, said trough being formed in the base of the furnace, substantially as shown and described.

4. The guard-flanges *ee'*, in combination with the cylinder D and trough *e^t*, substantially as and for the purposes specified.

In testimony that I claim the foregoing, I have hereunto set my hand this 6th day of November, 1874.

ENOCH WOOD.

Witnesses:

T. J. MCTIGHE,
PETER KREUTER.