

J. H. LAKEY.

Device for Drilling Rails.

No. 161,418.

Patented March 30, 1875.

Fig. 1.

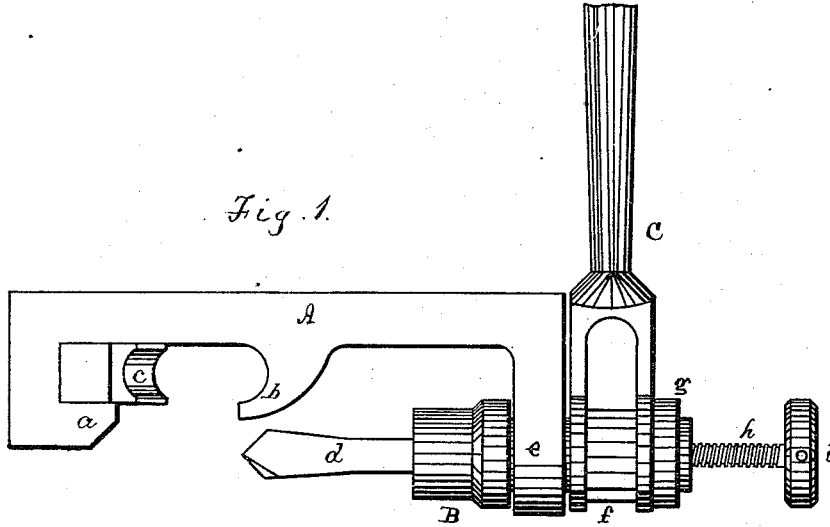
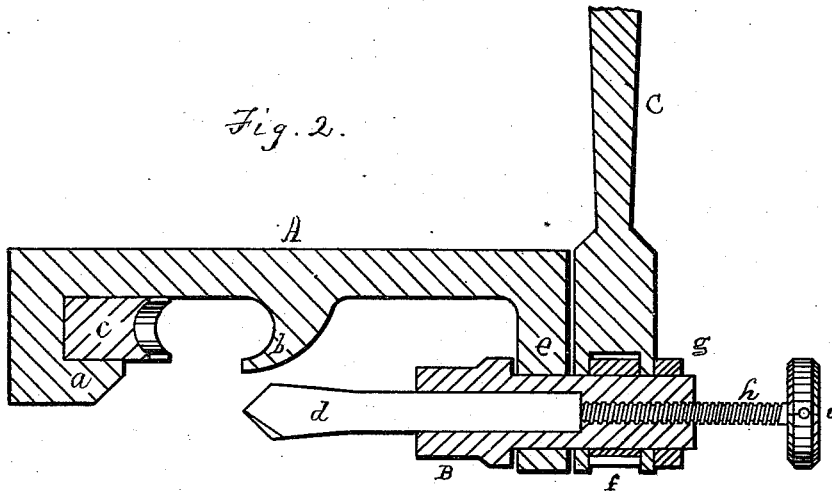

Fig. 2.



Witnesses.
E. A. West
O. W. Bond

Inventor.
J. H. LaKey

UNITED STATES PATENT OFFICE.

JOHN H. LAKEY, OF TURNER JUNCTION, ILLINOIS.

IMPROVEMENT IN DEVICES FOR DRILLING RAILS.

Specification forming part of Letters Patent No. 161,418, dated March 30, 1875; application filed December 22, 1874.

To all whom it may concern:

Be it known that I, JOHN H. LAKEY, of Turner Junction, in the county of Du Page and State of Illinois, have invented new and useful Improvements in Drills, of which the following is a full description, reference being had to the accompanying drawings, in which—

Figure 1 is a side elevation and Fig. 2 a vertical section.

The chief object of this invention is to construct a drill which can be readily attached to the top of an ordinary T-rail, and be used for mending broken rails on the track.

Heretofore drills have been used for this purpose so constructed that they can be secured to the under side of the rail, which cannot be done except between the ties, and then the ground must be dug away under the rail, which it is not always easy to do.

Another object is to simplify the construction of the drill, which I do by so making it that the drill proper is advanced by an independent screw instead of by the movement of the drill-head and operating-lever.

In the drawings, A represents the frame which carries the operative parts of the drill. It has two jaws, *a b*, the inside of one of which conforms to the shape of the head of the rail upon which the frame is to be placed. The other is adapted to receive the key *c*, which may be used to hold the frame in place upon the head of the rail. This frame may be made either of wrought or cast metal, and should be two inches or more in width on the top. B is the drill-stock, which passes through and can be revolved in the part *e* of the frame. C is the handle or lever for operating the drill. It is provided with a ratchet, *f*, and is to be secured to the drill-stock B by means of a collar, *g*, or in some other known manner. In the drill-stock B is a deep socket which receives the drill *d*. *h* is a screw which passes through the head or outer end of the drill-stock, and by the use of which the drill *d* is advanced. The head of this screw may be provided with

arms or with holes *i* to receive one or more removable arms. The jaws *a b* are stationary.

It is customary to mend broken rails on the track by drilling holes through the neck and applying a fish-joint. This work can be greatly facilitated by the use of my device.

In use the frame A is secured to the top of the rail, most conveniently by a key, *c*. The drill *d* does not advance simply by the movement of the lever C, as is usual, but the operator holds the screw *h* by means of one of the arms, so as to prevent it from turning with the movement of the drill-stock B, but the drill-stock will turn on *h*, carrying it forward and forcing the drill forward. To do this, however, if the movement of the lever C, when operating the drill-stock, be right-handed, the screw *h* must be left-handed. This mode of advancing the drill enables me to make a cheaper device for the purpose than those now in use, but equally efficient. The parts may be made of any suitable metal.

The drill-stock can be driven by the use of gear-wheels, its movement being continuous instead of intermittent, as when the ratchet is used; hence I do not confine myself to the ratchet, though it is cheaper and less cumbersome than gearing.

The distinguishing feature of this part of my invention is in the construction of the parts, so that the drill is advanced by the independent screw *h* instead of with the drill-stock, as usual.

What I claim as new, and desire to secure by Letters Patent, is as follows:

The combination, as described and shown, of the frame A, key *c*, drill-stock B, and actuating lever or handle C with the sliding drill *d* and screw *h* acting directly against the head of the drill, substantially as specified.

J. H. LAKEY.

Witnesses:

E. A. WEST,
O. W. BOND.