

J. ROSS.

Wood-Planing Machine.

No. 161,444.

Patented March 30, 1875.

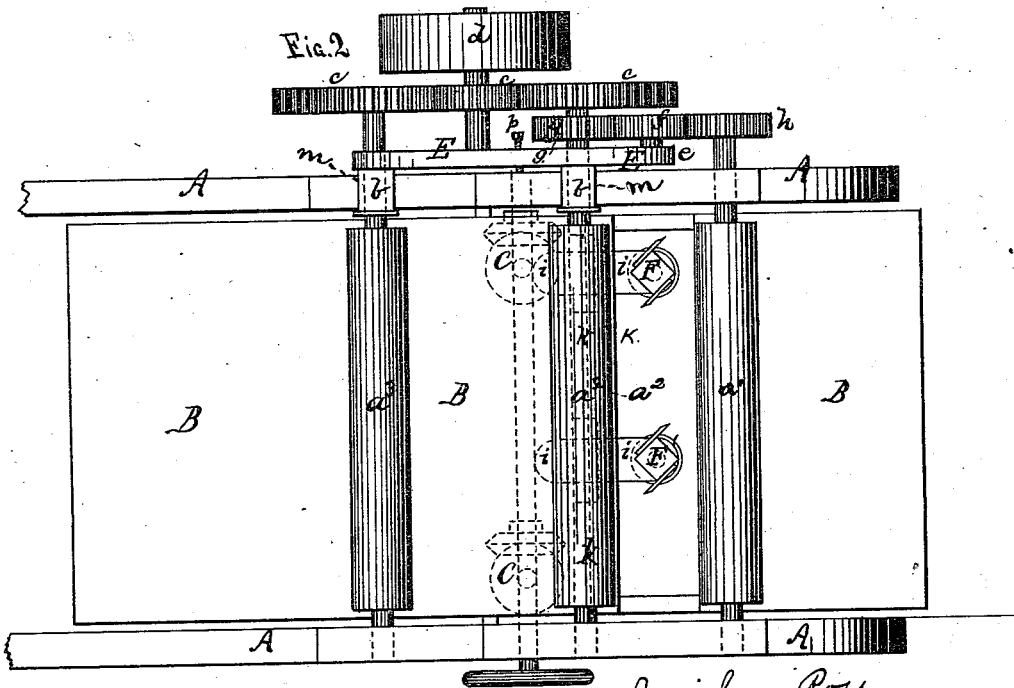
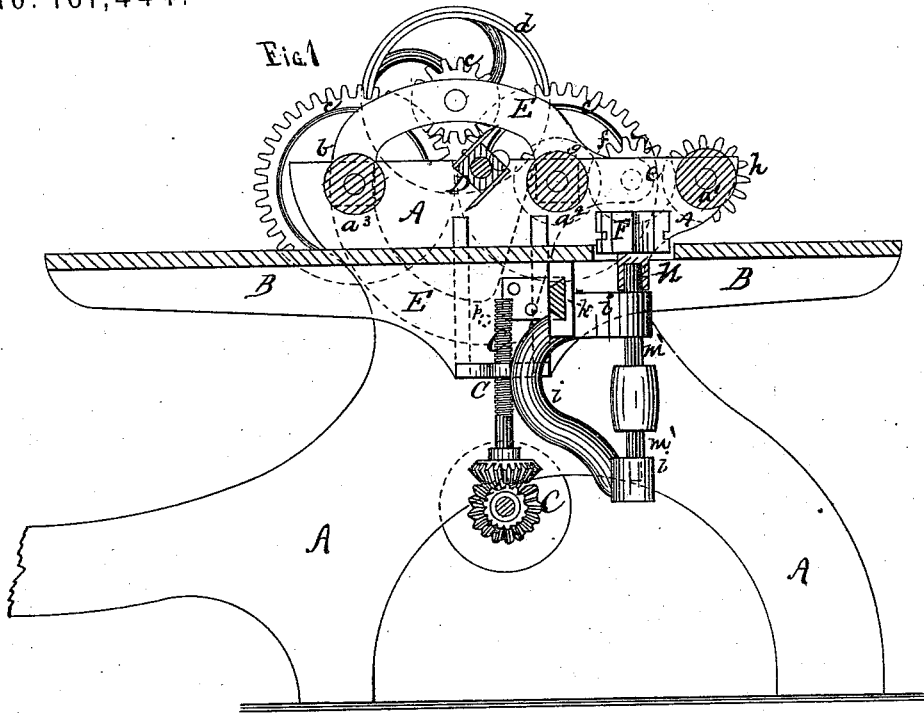

WITNESSES.
C. N. Woodward
Edward Martin Esq.

Josiah Ross
INVENTOR, By
C. N. Woodward, Atty.

UNITED STATES PATENT OFFICE.

JOSIAH ROSS, OF BUFFALO, NEW YORK.

IMPROVEMENT IN WOOD-PLANING MACHINES.

Specification forming part of Letters Patent No. 161,444, dated March 30, 1875; application filed January 13, 1875.

To all whom it may concern:

Be it known that I, JOSIAH ROSS, of Buffalo, in the county of Erie and State of New York, have invented certain new and useful Improvements in Wood-Planing Machines, of which the following is a specification:

The invention relates to wood working or planing machines; and consists in connecting a yoke or frame (to which the gearing, &c., for operating the feed-rollers is attached) to the boxes in which the feed-rollers run, by which the gears are always held in the same relative position to each other, no matter what the position of the feed-rollers may be, as hereinafter described.

The invention further consists in attaching the matcher cutter-heads and frames to a movable or adjustable table in such a manner that they will be raised and lowered with the table, as hereinafter set forth.

In the drawings, Figure 1 is a sectional side elevation. Fig. 2 is a plan view.

A is the frame, having the usual adjustable table or bed B, operated by bevel-gears and screws C, as shown. D is the cutter-head, and $a^1 a^2 a^3$ the feed-rollers. E is a yoke or frame cast in one piece with the boxes $b b$ of the feed-rollers $a^2 a^3$, as shown, and carrying the operating gears $c c c$ and pulley d . This yoke is continued forward at e , and has attached to it a small idle pinion, f , which is driven by a pinion, g , on the shaft of the feed-roller a^2 , and in turn meshes into and drives a third pinion, h , which operates the first feed-roller a^1 . Upon one side of the frame A of the machine are notches $m m$, within which the boxes b of the yoke E are placed, to allow the boxes to play up and down.

This yoke is a very important feature of my invention, as by its arrangement the whole of the mechanism for operating the feed-rollers is firmly held together in one frame, and when the feed-rollers are raised or lowered by the pressure of the lumber passing beneath them (the boxes of the rollers having rubber springs above them to allow them to give a little) the gears will all be raised together, and thus prevent crowding or jam-

ming them, which would occur were they not thus arranged.

The lug e for carrying the idle pinion f is also an important feature, as by its use the pinions are kept in line, and will not jump or jam by the rising and falling of the feed-rollers—which would be the result if it were attached directly to the frame—and prevents any sudden change of pressure from effecting them.

The action of the lumber in elevating the feed-rollers slightly, and carrying with them, through the frame E, the gears and driving-pulley d , will cause the belt to be strained in a small degree just when and where it required to be tight, and when the lumber passes out the rollers will fall again, and so relieve the strain from the belt. This is a very useful and convenient feature, and is a self-acting belt-tightener.

The constant strain upon the yoke by the belt has a tendency to pull the frame downward, and would, if nothing were done to prevent, soon ruin the machine. But to prevent this, I secure to the bottom of the yoke a set-screw, p , by which all sagging is prevented, and the frame always kept true and steady.

F F' are the matcher cutter-heads, having the usual frames $i i'$, one being stationary, and the other movable upon a dovetailed slide or bar, k . This bar is secured to the table B, and thus enables the matchers to be raised and lowered at the same time with it, which is not accomplished by any other machine with which I am acquainted, and is another very important feature of my invention, as by its use I avoid the use of a separate frame and adjustment.

The spindle m' is made with its top n below the surface of table, so that when it is required to use the machine without the matcher, for planing only, it will be necessary to remove the cutter-heads alone, and leave the spindles in place.

I claim—

1. In combination with the frame A, having notches $m m$ upon one side, the yoke E, having the boxes $b b$ and lug e , all cast in one

piece, and carrying the operating gears C, and connected with the feed - rollers a^2 a^3 , substantially as and for the purposes set forth.

2. In a rotary wood - planing machine, the adjustable table B, having the matcher cutter - head frames attached to and operating in connection therewith, substantially in the manner and for the purpose hereinbefore specified.

In witness whereof I have hereunto set my hand in the presence of two subscribing witnesses.

JOSIAH ROSS.

Witnesses:

C. N. WOODWARD,
T. H. PARSONS.