

J. C. H. STUT.

Rotary, Reversing and Cut-Off Valve.

No. 161,452.

Patented March 30, 1875.

Fig. 1.

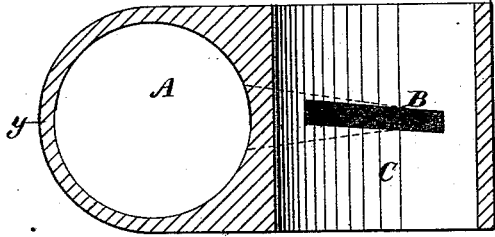

Fig. 2.

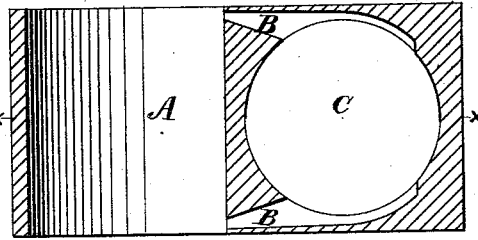

Fig. 3.

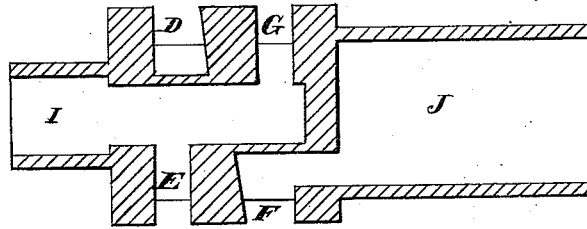

Fig. 4.

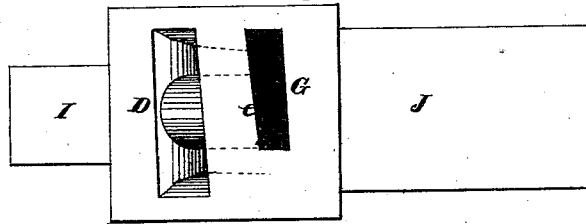
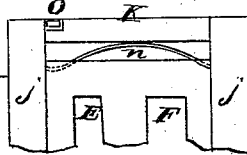

Fig. 5.



Witnesses
Geo. H. Strong
Jos. L. Boone

Inventor
John Christian Henry Stut
 by *Rewey & Co*
 Attys

J. C. H. STUT.
Rotary, Reversing and Cut-Off Valve.
No. 161,452. Patented March 30, 1875.

Fig. 6.

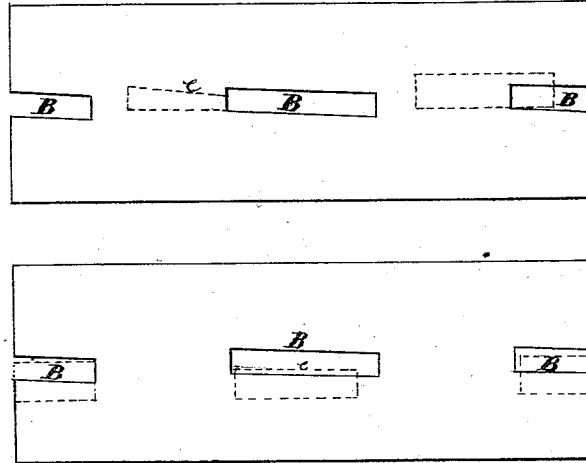

Fig. 7.

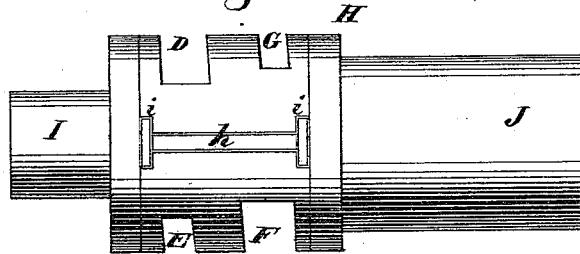

Fig. 9.

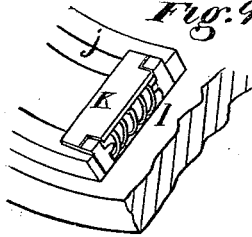

Fig. 8.

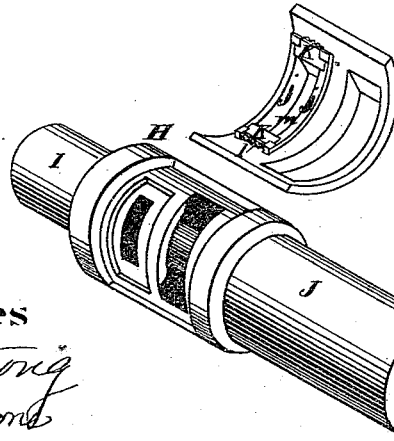
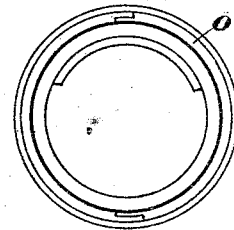

Fig. 10.



Witnesses
Geo. H. Strong
Geo. L. Brown

Inventor
John Christian Henry Stut
by Dewey & Co
Attys

UNITED STATES PATENT OFFICE.

JOHN C. H. STUT, OF SAN FRANCISCO, CALIFORNIA.

IMPROVEMENT IN ROTARY REVERSING AND CUT-OFF VALVES.

Specification forming part of Letters Patent No. 161,452, dated March 30, 1875; application filed February 25, 1875.

To all whom it may concern:

Be it known that I, JOHN CH. HENRY STUT, of San Francisco city and county, State of California, have invented a Cylindrical Double-Acting Valve; and I do hereby declare the following description and accompanying drawings are sufficient to enable any person skilled in the art or science to which it most nearly appertains to make and use my said invention without further invention or experiment.

My invention relates to certain improvements in the valve of steam-engines, by which I am enabled to obtain all the advantages of a variable cut-off, and consequent working of the steam expansively, as well as a great simplicity of mechanism and fewness of the working parts.

Referring to the accompanying drawings for a more complete explanation of my invention, Figure 1, Sheet 1, is a horizontal section taken through $x x$, Fig. 2. Fig. 2 is a vertical section taken through $y y$, Fig. 1. Fig. 3 is a longitudinal section of the valve. Fig. 4 is a front view of the valve. Fig. 5 is a section of a valve, showing spring for holding the rings steam-tight. Fig. 6, Sheet 2, shows the operation of the valves. Fig. 7 is a side view of the valve. Fig. 8 is a perspective view, with one packing-ring removed. Figs. 9 and 10 are details of the valve.

A is the steam-cylinder, within which the piston is moved alternately from end to end. B B are ports, which lead from the ends of the cylinder to the cylindrical valve-chamber C. In the present case the cylinder is placed vertically, while the valve-chamber lies horizontally and the ports open into the chamber, one on the upper side and the other just opposite, upon the lower side, in the form of elongated slots, which stand at a small angle transversely with the axis of the chamber, so that, if continued entirely around, they would form spirals. This angle of the ports is plainly shown at Fig. 6, which represents the inside of the valve-chamber unrolled, as it were, upon a flat surface. My valve is also cylindrical, and is fitted so as to be steam-tight within the chamber, as will be more fully described hereafter. The valve has two sets of openings, one exhaust, D, and one steam-port, E, lying in the same plane and on opposite sides of the valve,

while the other pair of ports, F G, for reversing the engine, lie in a plane parallel with the first, the exhaust-port F for the reverse movement lying beside the steam-port E of the forward motion, and the steam-port G of the reverse by the side of the exhaust-port D of the forward motion, so that, by moving the valve endwise in its chamber, either set of ports can be made to open into the ports B, and their width of opening can also be regulated. One end of the valve H is made considerably smaller than the main part, as shown at I, and serves as an ingress-pipe for steam. This pipe connects with both steam-ports, the one not in use being at all times closed, because it is always in contact with the inner face of the valve-chamber, while the other alternately comes opposite the upper and lower steam-port B. The exhaust-ports act in the same manner, and are each connected with a passage through the interior of the portion J of the valve, which is hollow and open at its outer end, to allow the steam to escape in that direction.

In order to allow of this end movement of the valve and still maintain the pipe I steam-tight, it is accurately fitted to slide outside or within the conducting steam-pipe, the joint being stuffed, so that the end motion can be produced without leakage.

The operation of my valve will be as follows: The valve being set by means of any suitable lever-connection, so that one set of ports are in a line with the ports B B of the chamber, steam is admitted and the engine moves. Any positive connection, as gearing, may be made between the engine-shaft and the valve, so that the latter shall move accurately and in conjunction with the piston. The steam-ports E and G of the valve are in the present case two inches in length, while the ports B of the chamber are two and thirteen-sixteenths inches long.

By this construction my valve remains fully open while it is passing over this thirteen-sixteenths difference in the length of the ports, which is of great advantage, as it gives the steam an opportunity to exert its full pressure, and the size of the port is not so quickly reduced after its full opening.

The exhaust-ports are equal in length to the bridge between the ports B B of the chamber,

(one-eighth less than the length of the ports B,) so that, as soon as it is entirely closed to one of the ports, it will be instantly opened to the other, and there will be no back pressure.

To reverse the engine, it will only be necessary to slide the valve along in its chamber until the two ports F and G are brought to rotate in a line with the ports B.

It will be seen from the length of the ports E and G that they will cut off the steam from the ports B some time before the piston reaches the end of its stroke, and this constitutes a constant cut-off, which is determined by the length of these ports. The distance between the inlet-ports is equal to the length of the bridge measured on the circumference of the valve.

The variable cut-off is regulated by moving the valve in its chamber, so that when rotated it will uncover only a portion of the steam-port, although the exhaust-port is made enough wider to present sufficient clearance not to choke.

The ports B being, as before described, placed spirally around the chamber, and one side, *e*, of the steam-port E or G in the valve being also made to stand at an angle, as shown, it will be seen that when the variable cut-off is to be used, the opening will be largest when the ports E and B first meet, and the inclination of each will be such that, as the port E passes over the port B, the opening will be gradually narrowed down, and may be entirely closed at any point in the stroke, the point of closing depending upon the distance which the valve has been moved endwise in the chamber.

By this construction I am enabled to adjust the amount of my cut-off to the greatest nicety.

In order to keep my valve packed perfectly tight, I have constructed the moving face in two semi-cylindrical segments, which form one-half each of the circumference of the valve. Their meeting edges are packed by means of a longitudinal strip, *h*, and two transverse strips, *i i*, at the ends of this longitudinal strip. The segments lie upon the interior portion of the cylindrical valve, and the ports correspond with the openings to the interior of the part I. The meeting edges of these openings are packed by metallic strips *j* and *k*, these being held in position by means of

springs *l*, as shown, when steam is not on. The pressure of the steam upon the interior of the ring at *m* also serves to keep its center in contact with the chamber, while the ends are held up by springs, as shown at *n*.

A metallic ring, *o*, is fitted into the edge of the segments, and by means of these devices and the steam-pressure the segments are always held closely to the interior of the valve-chamber.

Having thus described my invention, what I claim, and desire to secure by Letters Patent, is—

1. The cylindrical valve-chamber C, having the ports B B extending around the inside of the chamber spirally, or at an angle with a circular cutting-plane, in combination with a rotating valve having steam and exhaust ports to correspond with the ports B, substantially as herein described.

2. The valve H, having the two sets of steam and exhaust ports D E and F G situated in parallel planes, which cut the valve at right angles with its axis, so that one set may be used in admitting steam to move the engine in one direction, and the other set to reverse it, substantially as herein described.

3. The cylindrical rotary valve H, having two steam and two exhaust ports for forward and reverse motion, said valve being provided with a sliding steam-pipe, I, so that the valve may have a motion endwise in its chamber, to bring either set of ports in a line with the ports B B without causing leakage, substantially as herein described.

4. The rotary valve having the steam-ports E and G, one side, *e*, of which is made angular or inclining, so that by moving the valve endwise either of these ports will give a variable steam-opening in connection with the spirally-arranged ports B B in the valve-chamber, substantially as herein described.

5. The cylindrical valve-face H, composed of two segments, and provided with the packing-strips *h* and *i*, the interior strips *j* and *k*, and springs *l*, and the end springs *n*, substantially as herein described.

In witness whereof I hereunto set my hand and seal.

JOHN CHRISTIAN HENRY STUT. [L. S.]

Witnesses:

GEO. H. STRONG,

JNO. L. BOONE.