

R. S. CHAFFEE.
Magazine Fire-Arm.

No. 161,480.

Patented March 30, 1875.

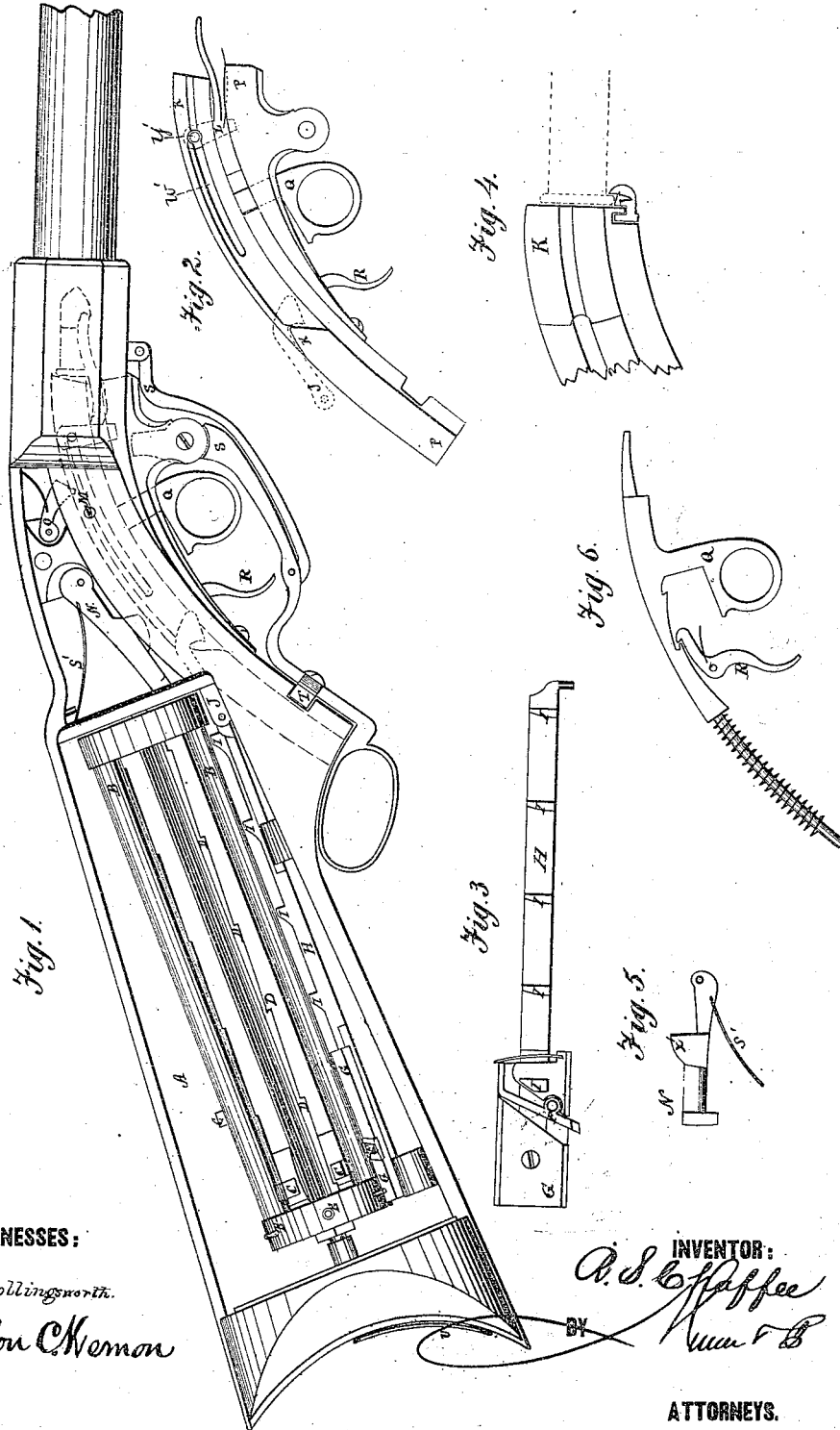

WITNESSES:
W. W. Hollingsworth.
John C. Kemmer

INVENTOR:
R. S. Chaffee
BY
Wm & B

ATTORNEYS.

UNITED STATES PATENT OFFICE.

REUBEN S. CHAFFEE, OF SPRINGFIELD, ILLINOIS, ASSIGNOR OF ONE-HALF
HIS RIGHT TO BERNARD STUVI, OF SAME PLACE.

IMPROVEMENT IN MAGAZINE FIRE-ARMS.

Specification forming part of Letters Patent No. 161,480, dated March 30, 1875; application filed
February 9, 1875.

To all whom it may concern:

Be it known that I, REUBEN S. CHAFFEE, of Springfield, Illinois, have invented an Improvement in Revolving Magazine Fire-Arm, of which the following is a specification:

The object of my invention is the perfection of a breech-loading fire-arm, with a revolving magazine of large capacity inclosed in its hollow stock, and having a reciprocating or positive motion, which is light, simple in its use, and admits of great rapidity in firing, and which, having its stock closed on top, prevents the escapement of any powder in being discharged.

The description of my invention is illustrated in detail by the drawings hereto annexed, in which Figure 1 is a side elevation of the gun, with the cap and plate removed to show the mechanism; Fig. 2, a detail of the breech-block and its attachments; Fig. 3, a detail of the loading-bar and its attachments; Fig. 4, a detail of the cartridge-extractor, showing its relation to the breech-block and the cartridge; Fig. 5, a detail of the cut-off; and Fig. 6, a detail of the hammer, its spring, and the trigger.

In the hollow metal stock of the gun, exhibited by the letters A A in the drawing, is placed the revolving magazine, consisting of six tubes, marked B. These tubes contain each a cartridge-driver, C, which is held in position by their notched openings, marked D. The cartridge-drivers have springs attached to them to force them into the notched openings of the tubes, but in large guns such springs will not be required. The number of tubes in the magazine may be more or less than six. Corresponding to the number of the tubes are placed at the lower end of the magazine pins marked E, which aid in turning it. At the lower end, and outside of the stock, is a clasp-pin, marked U, which serves to hold the magazine in position, and by turning which it is unfastened. Below the magazine lies what I denominate the loading-bar H, on which are arranged lugs I, for carrying forward the cartridge-drivers. Toward the back end of this loading-bar is the stop-plate G, in which is the spring-cam marked F. These, with the pins E, both serve to turn and

stop the revolving of the magazine. To the forward end of the loading-bar is attached an independent hook, marked J, and under the neck of the gun-stock works, in its partly-circular groove, the breech-block marked P P, containing notches marked K K, and as the breech-block is moved forward and back by its lever S these notches strike the hook J, which imparts a corresponding motion to the loading-bar, and it, in turn, by means of the pins E and spring-cam F, to the magazine, causing it to revolve. To the front of the breech-block is attached a finger, marked L, for the purpose of holding in position the cartridge as it is pushed forward into the barrel. Said finger is provided with a stud, y' , which works in a slot, w' , and which strikes against the hook J when the breech-block is pushed backward, for the purpose of propelling the finger L to the front part of its slot w' , and in position to receive the cartridge from the cut-off N. In the neck of the stock, immediately in front of the magazine-chamber, is another but smaller chamber, containing the cut-off marked N, with spring S' and cam X', to direct the cartridge in its passage downward and forward of the breech-block. The spring S' causes the cut-off to close the communication with the revolving magazine, and its cam X' causes it to be lifted up by the forward movement of the breech-block to reopen the communication, and receive beneath its concave face the cartridge pushed out by the loading-bar. M is a stud for moving the finger L out of position to allow the shell of the cartridge to be expelled by the extractor V, in connection with which works also the spring-catch marked O. Q is the hammer, inclosed by a spiral spring, and R is the trigger. T shows the point where the breech-block is locked.

To work the gun, open the cap of the magazine-chamber, and, by turning the clasp-pin U a quarter up and pushing it backward, the magazine is unfastened. To load it, run the cartridge-drivers C down the tubes, and fill the latter with cartridges, putting one first in the opening under the concave face of the cut-off N. Replace the loaded magazine, lock the clasp-pin, and the gun is ready to be dis-

charged. To do this, throw forward the lever to full stroke. Now, in the passage of the breech-block back by means of the lever, the hook J moves the finger L into position; the loading-bar slides down; the spring-cam F comes in contact with the pins E, causing the magazine to revolve till the stop-plate arrests it, when the loading-bar, with its lugs behind the drivers, carries forward the cartridge, which is forced downward by the cut-off N before the breech-block, where the finger L holds it in position until it enters the barrel; when, by pulling the trigger, the hammer strikes the cartridge, and the gun is discharged. As the cartridge enters the barrel, the stud M throws the finger L back of the extractor V and out of the way of the empty shell, which, in extraction, strikes the spring-catch O, working in connection with the extractor, and is caused to fly out; and thus, while the cartridges in the magazine last, the gun may be fired as rapidly as the lever can be worked back and forth and the trigger pulled, and this without removing it from the shoulder.

In throwing out the lever the hammer may be full or half set, according as the former is thrown forward to full or half stroke.

I claim as my invention—

1. The pins E of the revolving magazine, in combination with the spring-cam F and the loading-bar H, operating as described, for the purpose of turning the said magazine.

2. The tubes B, having notched openings D, in combination with the cartridge-driver C, provided with springs, substantially as and for the purpose described.

3. The loading-bar H, with its lugs I, its stop-plate G, the spring-cam F, and its hook J, all combined and arranged substantially as shown, and for the purpose described.

4. The hollow breech-block P P, having shoulders K K, its finger L, trigger R, hammer Q, and extractor V, all arranged substantially as and for the purpose described.

5. The cut-off N, with its cam and spring, in combination with the revolving magazine and the breech-block, substantially as and for the purpose described.

6. The stud M, in combination with the finger L, substantially as and for the purpose described.

REUBEN SHIPLEY CHAFFEE.

Witnesses:

A. W. COLEMAN,
J. D. SHARPE.