

A. W. CRAM.
Grate-Bars.

No. 161,485.

Patented March 30, 1875.

Fig. 1.

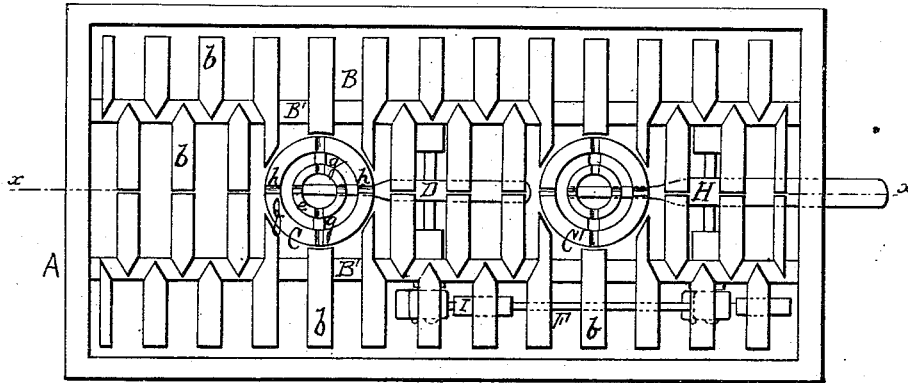

Fig. 2.

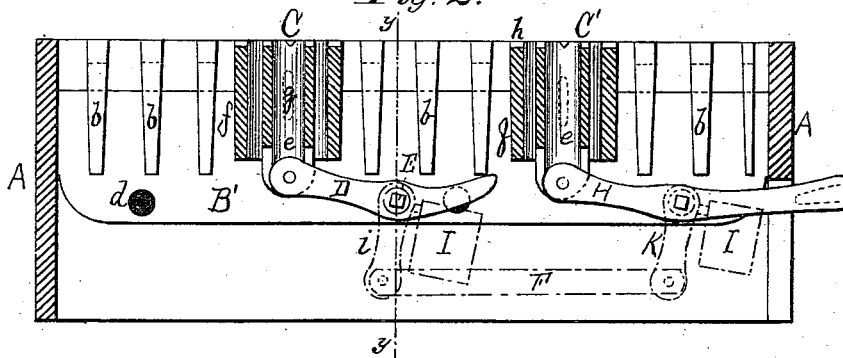
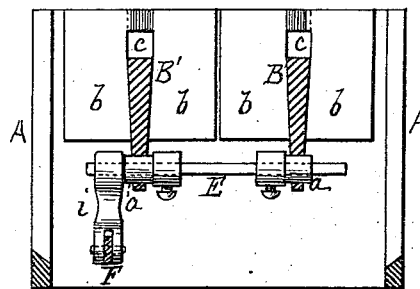

Fig. 3.



Witnesses:

Edwin James.
John R. Jones.

Inventor:

Alonzo W. Cram.
per J. E. F. Holmead,
Attorney.

UNITED STATES PATENT OFFICE

ALONZO W. CRAM, OF HAVERHILL, MASSACHUSETTS.

IMPROVEMENT IN GRATE-BARS.

Specification forming part of Letters Patent No. 161,485, dated March 30, 1875; application filed January 28, 1875.

To all whom it may concern:

Be it known that I, ALONZO W. CRAM, of Haverhill, in the county of Essex and State of Massachusetts, have invented certain Improvements in Grate-Bars, of which the following is a full, clear, and exact description, reference being had to the accompanying drawing and the letters of reference marked thereon, making part of this specification, in which—

Figure 1 is a top or plan view of my invention. Fig. 2 is a longitudinal sectional view on the line *x x*, Fig. 1, showing the operating-levers in dotted lines. Fig. 3 is a transversed section on the line *y y*, Fig. 2.

My invention relates to grate-bars for furnaces and other purposes; and consists in peculiarly-constructed grate-bars having a central main web or bar and short transverse side bars projecting over the adjoining main bars in such manner as to leave a clear opening or unobstructed passage for air the entire length or upper face of the bar, whereby the radiation toward the lower part of the bar is greatly lessened and they are prevented from burning out.

My invention also consists in peculiarly-shaped open-top air-tubes, arranged between the bars to supply additional air to the fire. These air-tubes are operated by rock-shafts and levers, all of which will be more fully described hereafter.

The construction and operation of my invention are as follows:

A is a suitable frame, in which the grate-bars and air-tubes are arranged according to width and length of furnace, more or less bars and tubes being used. The grate-bars B consist of a main or central longitudinal web, B', and transverse side bars *b b*, which are arranged in a staggering manner, so that one bar comes opposite the space on the other side. These side bars have also their edges, which project over the central web from each side, recessed out to leave a continuous opening or passage, *c*, as clearly shown in Fig. 3, and allow a free circulation of the air over the web B', by which the radiation of the heat from above is greatly lessened, the bars are prevented from burning out so quickly, and are not liable to be warped. In the lower

part of the web B' are arranged four (more or less) holes, *d*, for the boxes of the rock-shafts, as will be more definitely explained hereafter. Between the grate-bars, in any desirable number, and on a level with the side bars *b*, are arranged open-top air-tubes C C'. These tubes consist of an inner and outer tube, *e f*, secured together by two or more ribs, *g*. The upper faces of said tubes are provided with radial slots or depressions *h*, to prevent large pieces of coal from clogging or choking the passage or draft of air over the ends of the tubes. The lower end of the inner tube *e* is provided with suitable jaws, which clasp one end of a lever, D, secured to a shaft, E, that is journaled in small boxes *a* in the web of the adjoining grate-bars, as seen in Fig. 3. Set-collars hold the shafts in position. On the outer end of the shaft E a pendent arm or lever, *i*, is secured, connecting, by means of a link or connecting-rod, F, with a similar arm, *k*, on the rock-shaft G, and operating the air-tube C' by the lever H. The outer end of the lever D projects to form a stop against the lower edge of the side bars and prevent the tubes C from dropping below the surface of the grate-bars, while the outer end of the lever H forms a handle or connection to operate or set the tubes in any desired position. The weights I I are arranged on the arms or levers to counterbalance the tubes and to dispense with ratchets, pawls, or other complicated gear. The holes *d* in the webs B' of the bars are arranged to change the rock-shafts from one side to the other.

The operation will be readily understood by those familiar with the art to which my invention appertains.

I am aware that grate-bars having a central web and side bars are known, and also that air-tubes with a closed or perforated top and operated by racks and pinions have been used; but these are very quickly burned out, and therefore such I do not claim, broadly.

What I claim as new, and desire to secure by Letters Patent of the United States, is—

1. A grate-bar, B, consisting of a central web, B', and side bars *b b*, arranged to form the opening *c*, substantially as set forth.
2. The open-top air-tubes C C', consisting

of inner and outer tubes, and provided with slots or depressions *h*, as and for the purpose described.

3. The combination, with the air-tubes C C', constructed as described, of the rock-shafts E, levers D H, arms *i k*, and link F, arranged substantially as specified.

4. The combination of the grate-bars B, provided with side bars *b b* and opening *c*, with the open-top air-tubes C C', constructed as shown, and for the purpose described.

5. The combination of the grate-bars B,

having side bars *b b* and opening *c*, with the air-tubes C C', rock-shafts E, levers D H, arms *i k*, and link F, all constructed and operated substantially as described.

In testimony whereof I have signed my name to this specification in the presence of two subscribing witnesses.

ALONZO W. CRAM.

Witnesses:

A. F. CRAM,
MILTON CHASE.