

A. HILTS.
Field-Roller.

No. 161,512.

Patented March 30, 1875.

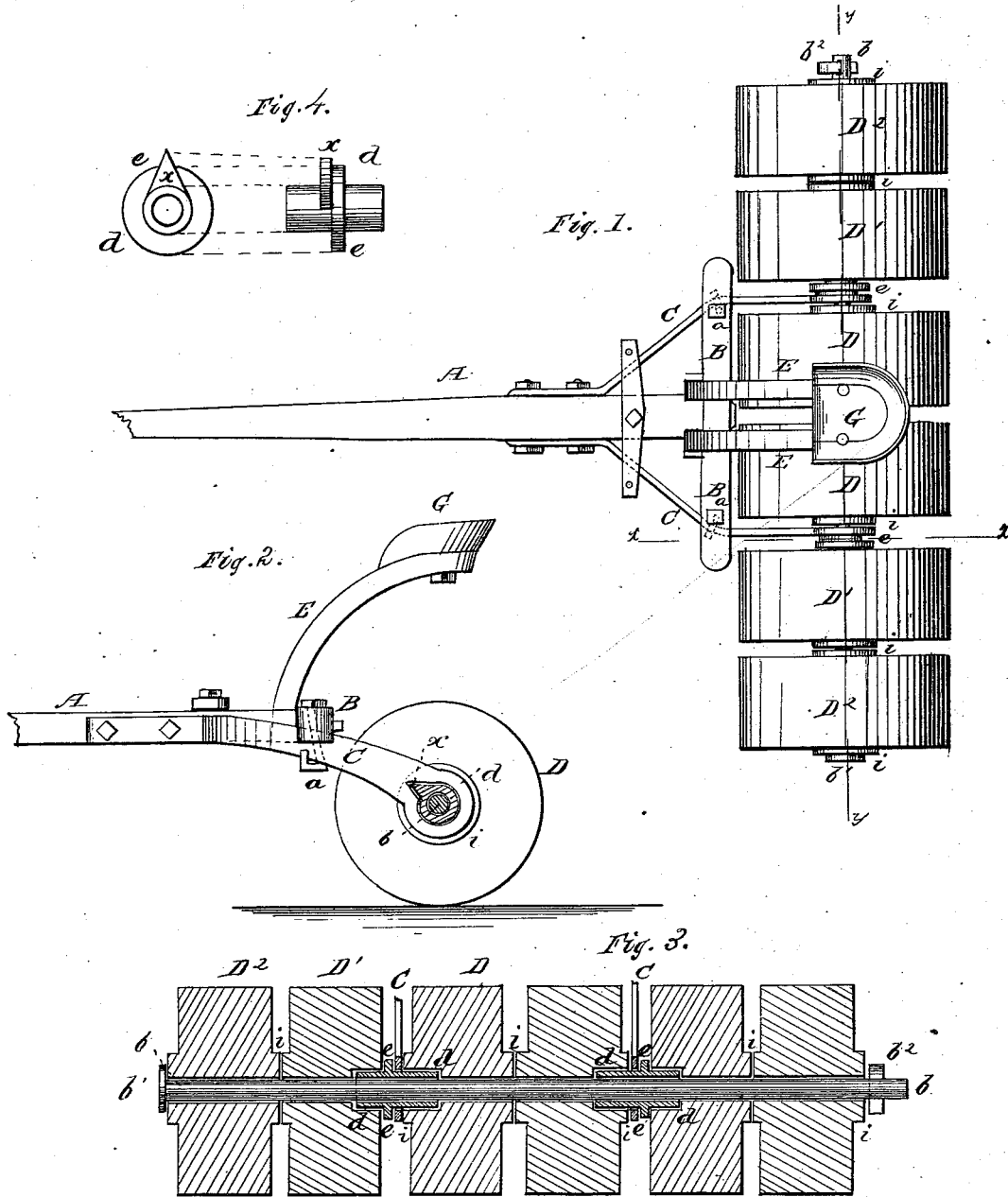

WITNESSES:
P. b. Dieterich
W. b. McArthur

INVENTOR:
A. Hiltz
per: S. H. Alexander
ATTORNEY.

UNITED STATES PATENT OFFICE.

ANTHONY HILTS, OF SPRINGDALE, OHIO.

IMPROVEMENT IN FIELD-ROLLERS.

Specification forming part of Letters Patent No. **161,512**, dated March 30, 1875; application filed February 23, 1875.

To all whom it may concern:

Be it known that I, A. HILTS, of Springdale, in the county of Hamilton and State of Ohio, have invented certain new and useful Improvements in Field-Rollers; and I do hereby declare that the following is a full, clear, and exact description thereof, reference being had to the accompanying drawings, and to the letters of reference marked thereon, which form part of this specification.

The nature of my invention consists in the construction and arrangement of a field-roller, as will be hereinafter more fully set forth.

In order to enable others skilled in the art to which my invention appertains to make and use the same, I will now proceed to describe its construction and operation, referring to the annexed drawings, in which—

Figure 1 is a plan view. Fig. 2 is a cross-section on the line *x x*. Fig. 3 is a central vertical section on the line *y y*, Fig. 1, and Fig. 4 is an enlarged view of sleeve *d*.

A represents the tongue, to which the team is attached. At the rear end of the tongue A is a cross-bar, B, to each end of which, on the under side, is fastened a draw-iron, C, by means of a hook-bolt, *a*. The front ends of the draw-irons are fastened to the tongue, while the rear ends are formed each with a circular hole, having a notch or slot on one side. From the rear end of the tongue extend two curved arms, E E, supporting the driver's seat G. Between the rear ends of the draw-irons C C are placed two rollers, D D, with a rod, *b*, passing centrally through them. The outer side of each roller D is formed with an enlarged central hole for the insertion of a sleeve, *d*, placed on the rod *b*. This sleeve is provided with a central circumferential collar or flange, *e*, and on the inner side of the same is a lug or projection, *f*, of suitable shape to fit in the notch made in the draw-iron. The sleeve *d* is passed over the rod and through the end of the draw-iron into the roller until the projection *f* enters the slot in the draw-iron and the collar *e* fits against the outer side of the iron. On each side of the two rollers on the rod *b* are placed two other roll-

ers, D¹ and D², the roller D¹ having an enlarged central hole on the inner side to fit over the outer end of the sleeve *d*. One end of the rod *b* is provided with a head, *b*¹, and in the other end is provided with a spring-key, *b*², holding all the rollers in their places on the rod. All the rollers are on both sides provided with slightly-projecting hubs *i* except the rollers D¹ D¹ on their inner sides, where the collars *e* of the sleeves answer the same purpose, whereby the friction between the rollers is avoided.

It will be seen that the team can be hitched close to the rollers, and the draft is directly on the rod passing through the centers of the rollers. The rollers revolve entirely independent of each other with the least possible amount of friction.

By removing the spring-key *b*² the rod *b* can be taken out and the rollers separated, allowing them to be stored away and take up but little room.

The driver's seat is so arranged that the driver can easily, by throwing his body back, throw the tongue upward, and have very little, if any, weight on the horses' necks.

The field-roller thus constructed is simple in construction, cheap, and durable, and not liable to get out of order.

Having thus fully described my invention, what I claim as new, and desire to secure by Letters Patent, is—

1. The combination of the draft-irons C C, sleeves *d d*, having collars *e e* and projections *f f*, and the rollers D D and D¹ D¹, substantially as and for the purposes herein set forth.

2. The combination of the tongue A, draft-irons C C, seat G, headed rod *b*, sleeves *d*, rollers D D, D¹ D¹, and D² D², and the spring-key *b*², all constructed substantially as and for the purposes herein set forth.

In testimony that I claim the foregoing as my own I affix my signature in presence of two witnesses.

ANTHONY HILTS.

Witnesses:

WILLIAM SELLERS,
JOHN M. COCHRAN.