

F. MANSFIELD.  
Machine for Boxing Matches.

No. 161,532.

Patented March 30, 1875.

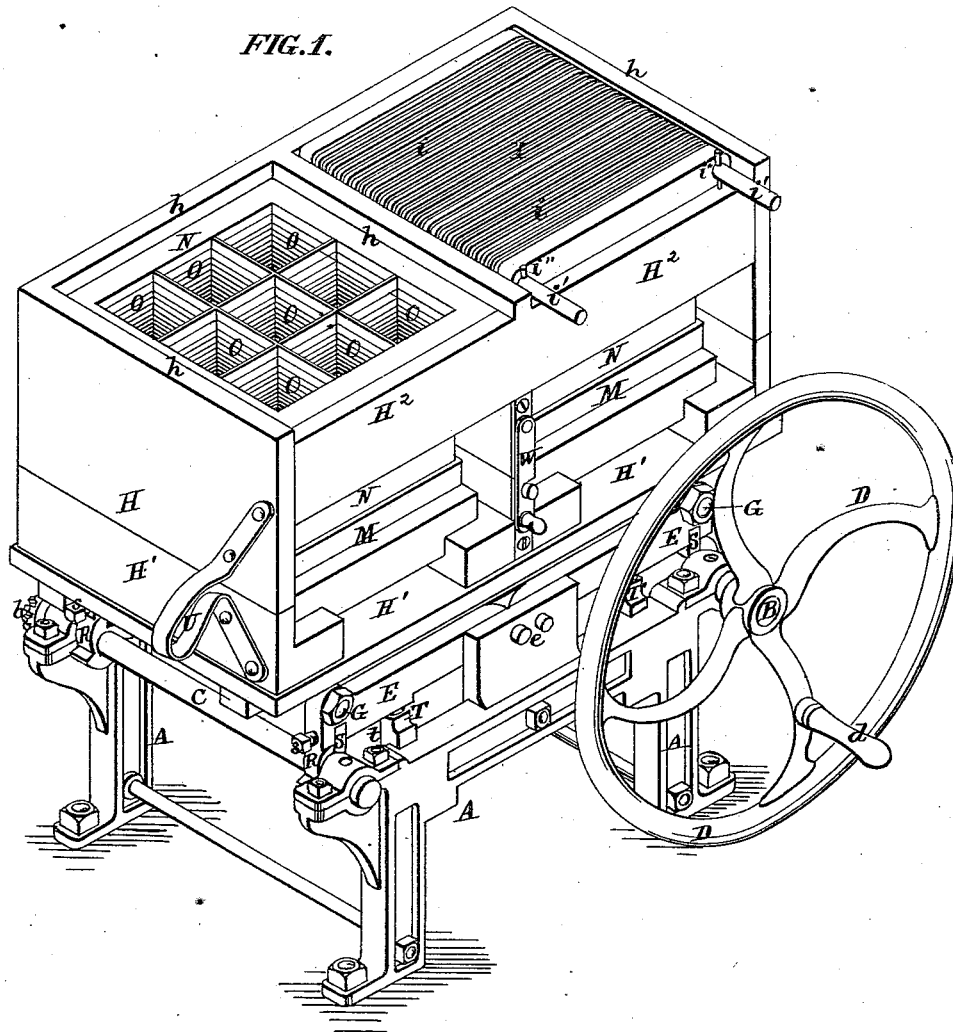

ATTEST:

*Robert Burns.*  
*Henry Tanner.*

INVENTOR:

*Fielding Mansfield*  
*By Knight Bro.*  
*Attys.*

F. MANSFIELD.  
Machine for Boxing Matches.

No. 161,532.

Patented March 30, 1875.

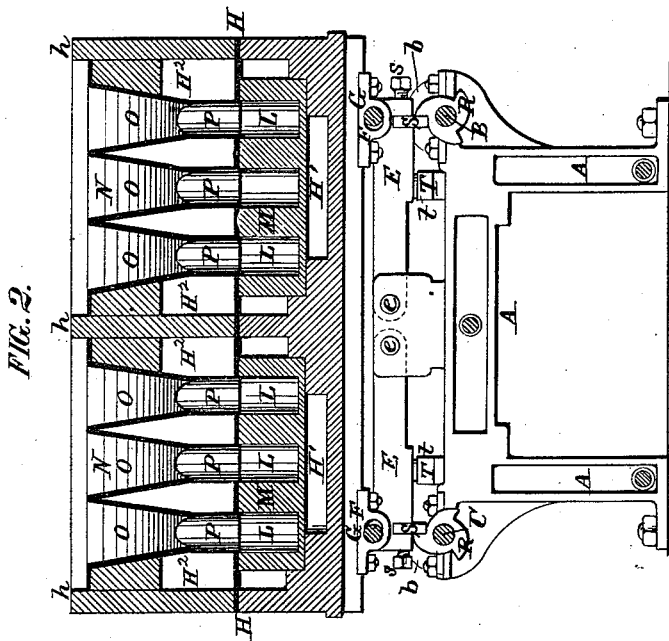
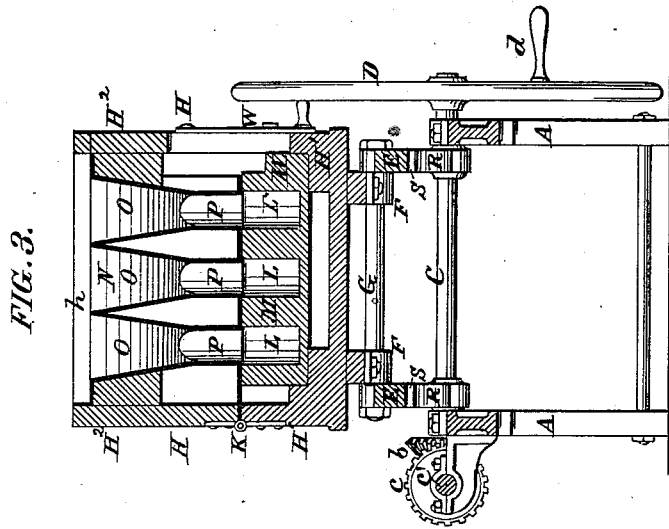

ATTEST:

*Robert Burns.*  
*Henry Tanner.*

INVENTOR:

*Fielding Mansfield*  
*By H. Light Bro.*  
*Atty.*

# UNITED STATES PATENT OFFICE.

FIELDING MANSFIELD, OF ST. LOUIS, MISSOURI.

## IMPROVEMENT IN MACHINES FOR BOXING MATCHES.

Specification forming part of Letters Patent No. 161,532, dated March 30, 1875; application filed December 16, 1874.

*To all whom it may concern:*

Be it known that I, FIELDING MANSFIELD, of St. Louis, St. Louis county, State of Missouri, have invented a certain new and useful Improvement in Machines for Boxing Matches, of which the following is a specification:

This invention relates to a machine for the reception of the dipping-frames when loaded with matches, and for forming the matches into bunches ready for insertion in the packing-boxes. By placing suitable boxes in the receivers the matches may be packed directly in the boxes by the machine.

The machine consists in a number of metallic funnels in a shaking body or box, the funnels receiving the matches as they are shaken from the dipping-frames, (by the agitation of the body,) and discharging them at the lower end into the receivers, which are also contained in the body. The shaking body is connected to the supporting-frame by arms, which allow vertical motion of the box or body. The vertical motion is communicated to the body by cams, which raise it, and then allow it to drop onto a number of anvils, so as to give the requisite jar to the matches contained in the frames to cause them to drop into the funnels, and the shaking is continued until the matches pass through the funnels and drop into the receiving-cups.

Figure 1 is a perspective view. Fig. 2 is a longitudinal section at *x x*, Fig. 3. Fig. 3 is a transverse section at *y y*, Fig. 4.

A is the supporting-frame, giving bearing to two transverse cam-shafts B C, geared together so as to be confined to simultaneous rotation by bevel-wheels *b* on the shafts engaging with similar wheels *c* at the ends of a longitudinal shaft, *c'*. Upon one of the shafts B is a fly-wheel, D, that may have a handle, *d*, by which the machine may be put in motion. But the machine is preferably run by steam-power; and to this end a fast and a loose pulley may be put on either of the shafts B or C, and the machine driven by a belt; or the power may be communicated by cog-gearing with a friction or other clutch to allow the easy putting in motion and stopping of the machine. Four arms, E E, &c., are hinged to the frame A at *e*, and are hinged to the

shaking body near the corners by boxes or straps F. These joints are made by transverse rods G G, which connect the outer ends of the arms E E together, as shown, and which pass through the bearings F F, &c. These joints are made so loose as to allow the necessary longitudinal movement of the rods G in their bearings, as the body H rises and falls in its shaking motion. This arrangement is rendered necessary because the movement of the rods is in the arc of a circle, and the body has a simple vertical reciprocation. The body H, as shown, consists of a lower portion, H<sup>1</sup>, connected to the arms G, and an upper portion, H<sup>2</sup>, connected to H<sup>1</sup> by hinges K on the rear side, so that the upper part H<sup>2</sup> can be thrown over backward to expose the bunches of matches in the cups or receptacles L of the receiving-tray M. N N are boxes, preferably of sheet metal, secured in the upper part H<sup>2</sup> of the body. Each box consists of a number of funnels, having a rectangular top, O, and a circular bottom or discharge-outlet, P. The mouths O of the funnels occupy the whole area of the top of the box N, being divided from each other by thin edges, so as to guide the proper number of matches into each funnel, as the matches are shaken from the dipping-frame I when the bars of the frame have been allowed to spread. The lower end P of each funnel is exactly over a receiving cup or receptacle, L, in the receiving-tray or receiver M, so that each cup receives the contents of one funnel.

The dipping-frame I consists of a number of parallel bars, *i*, strung upon rods *i'*, on which they may be slipped freely, and between the bars *i* the matches are held. The cups L are made of sufficient depth to prevent the matches falling out when the funnels are raised up from the receiver by the throwing back of the top portion H<sup>2</sup> of the body. The depth of the cups is such that the matches project sufficiently from their tops to allow of their ready grasp by the hand of the packer in boxing.

The cams R, by which the body H is actuated, are upon the transverse shafts B C, and are so arranged that all the corners of the body are raised simultaneously and allowed to fall at the same time. Each cam consists of a

ratchet-formed wheel, and the body is raised by the pressure of the inclined sides of the ratchet-teeth against the bearing-blocks S on the under side of the arms E. The blocks S may consist of lugs, cast or forged, or attached in any manner to the arms. I prefer to make said blocks of steel, mortised into the arms, and held in by key or set-screw, s, so as to be removable for renewal when worn. T T are anvils to receive the impact of the arms E F as the body descends, and thus a violent jerk is imparted to shake the matches from the dipping-frames and cause them to descend in the funnels, and to reach the bottom of the cups or receptacles L. The anvils I prefer to make of a wooden block, inserted in a suitable metallic socket, t, with a leather cap, so as to deaden the sound and preserve the metallic arms from injury. The funnels O P, and box N, in which they are fixed, I prefer to make of sheet metal, as this material gives a smooth surface; and the box, consisting of a shell of this material, with the funnels secured to its top and bottom, forms a light structure of ample strength. The receiving-trays M I have made of wood, as they have to be removed from the body, and are subjected to somewhat rough handling. I do not confine myself to the described material of construction. Surrounding each box N, upon all but the front side, is a raised marginal flange, h, inside which a dipping-frame fits, so as to hold it in position above the funnels, for the discharge of the matches.

The operation of the machine is as follows: The dipping-frames are placed in position over the funnels, with the dipped ends of the matches downward, and the bars of the frame allowed to separate by the removal of the holding-keys or pins <sup>i</sup> passing through the rods <sup>j</sup>. The separation of the bars allows the matches to drop down into the funnels, and this takes place upon the machine being put in motion, and, by the continued motion, the matches are shaken through the funnels and into the receiver-cups L. The motion of the machine is then stopped, the top H<sup>2</sup> thrown back, and the receivers M lifted out and passed

to the packers, by whom the matches are drawn out of the cups L and packed in the boxes in which they are sold. As the top H<sup>2</sup> is raised its backward movement is limited by guy-straps. When the top H is in working position it is held down by a catch, W, or other means. By the use of this machine the matches are counted with sufficient accuracy, as the top O of each funnel has the proper area to receive the required number of matches as they fall from the dipping-frame. The construction of the machine is such that the bunches of matches are kept entirely separate during their descent in the funnels, and, supposing a match to become ignited, the flame would not spread any further than to the other matches of the same bunch. It will be seen that as the whole weight of the body is received, when descending, upon the anvils T T, &c., the cams and cam-shafts do not suffer from the impact of the body in descending.

I claim herein as new and of my invention—

1. The combination of the dipping-frame I, and body H, having a vertical reciprocal motion, and constructed to support the dipping-frame while the matches are shaken therefrom, as set forth.

2. The shaking-box or body H, having funnels O P, and receivers M, and constructed to receive the matches in the funnels as they are shaken from the dipping-frames, and to deposit them in the receptacles L of the receiver, all substantially as set forth.

3. In combination with a body, H, having funnels O P, and receiver M, the jointed arms E E, &c., and cams R R, &c., all constructed substantially as and for the purpose set forth.

4. In combination with the body H, arms E E, &c., and cams R R, &c., the anvils T T, &c., to receive the impact of the arms, and relieve the cams and cam-shafts from the jar of said impact, as set forth.

FIELDING MANSFIELD.

Witnesses:

SAML. KNIGHT,  
ROBERT BURNS.