

G. W. MOORE.

Machine for Rowing Exercise.

No. 161,629.

Patented April 6, 1875.

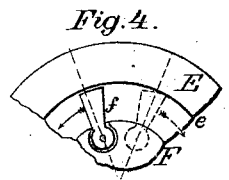
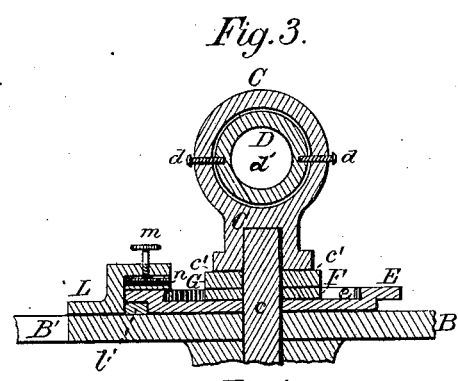
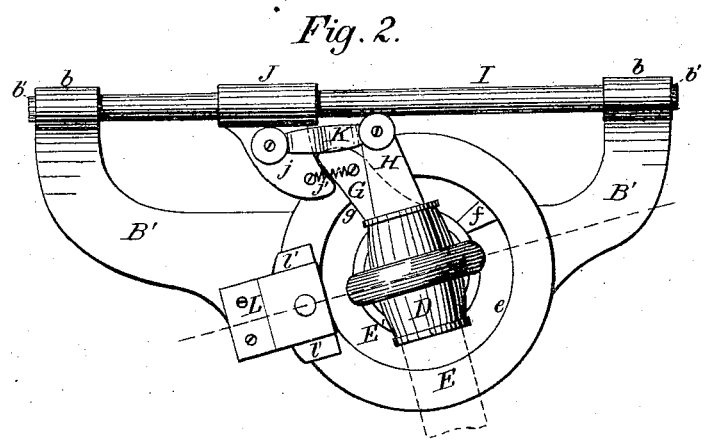
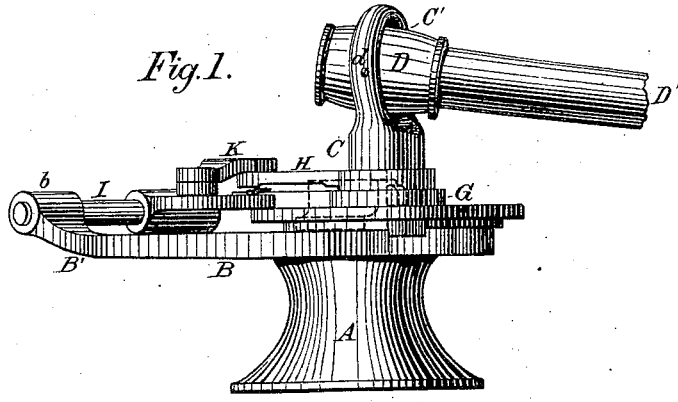

Attest:
N. H. Sherburne,
Benja. Severson

Inventor:
George W. Moore
By Newton Crawford atty.

UNITED STATES PATENT OFFICE.

GEORGE W. MOORE, OF NEWARK, NEW JERSEY.

IMPROVEMENT IN MACHINES FOR ROWING EXERCISE.

Specification forming part of Letters Patent No. 161,629, dated April 6, 1875; application filed February 19, 1875.

To all whom it may concern:

Be it known that I, GEORGE W. MOORE, of Newark, in the county of Essex, in the State of New Jersey, have made certain Improvements in Machines for Exercising in Rowing, in imitation of rowing a boat, of which the following is a specification:

The object of this invention is to provide a means for the practice and exercise of oarsmen, and give the exact, or nearly the exact, motion that an oarsman is to give his oar if in a boat, and the oar having its action upon the boat by a purchase in the water; also, to have the same degree of resistance acting against the force applied by the oarsman at different points of the stroke of the oar, the same as if the oar were in the water and the oarsman in a boat on the water; and it consists in the construction of the parts of the machine, and their arrangement with each other, and their action upon and with each other, as will be fully hereinafter described.

In the drawings, Figure 1 represents a perspective view; Fig. 2, a top or plan view; Fig. 3, a part upright sectional view; and Fig. 4, detail of parts.

A represents the pedestal or support of the actuating parts of the machine. B is a base-plate fast upon the support A, with curved arms B' B' extending from opposite sides, and then curving to one side, and at their terminal ends have cylinders *b*, with openings *b'* therein, to be upon the same line and plane to receive a guide-rod. C is a rowlock, having eye C' in its upper end, and fits over the pintle *c*, which extends down through plate B into the support A far enough, with the aid of shoulder *c'* on the rowlock, to support the rowlock in an upright position, and yet be free to partially rotate back and forth. D is an oar-socket, through which the hand part of the oar passes, and is suspended and held in the eye C' of the rowlock C by the pivot-screws *d d*, that pass through the bail of the rowlock, around the eye C', into opposite sides of the socket D, so that the socket, with the oar through it, will easily vibrate and accommodate itself to the proper motion of the oar as used in actual rowing. D' represents the hand part of the oar, and is inserted in the opening *d'* of the socket D, and so as to turn

or revolve therein, in imitation of feathering an oar in water. E is a horizontal wheel-plate, that is made to revolve around the center of the rowlock, and has a central sink, E', on its upper side, which forms an acute-angled wall, *e*, at the outer diameter of the sink. F is an annular plate fitted to turn around the pin *e*, and has a projecting pawl or clutch-arm, *f*, pivoted in and projecting outward from plate F, with the front edge a trifle larger in its extent than the back side, and placed in the position that its center of projection is away from a radial line from the center of pin *e*, and so that when the oar is forced away from the body of the oarsman the arm *f* will rotate back freely, but when the oar is being drawn toward the oarsman the front or longest part of arm *f* will engage with the wall *e* of wheel E, and cause the wheel E to revolve a portion of a revolution. G is a lever-arm, with an eye around the pintle or post *c*, the center of projection being out of radial line, but the face or straight edge *g* is on a radial line from the center of its rotation, and is caused to describe an arc of a circle around the post by an arm on a horizontal slide. H is another lever-arm projecting from and fast to the body of the rowlock C, and moves with the rowlock. I is a horizontal guide-rod, passing through the openings *b'* in the ends of the curved arms B' of plate B, and is made stationary therein. J is a traveling slide on guide I, and can freely reciprocate upon the guide, and has a curved arm, *j*, projecting inward and toward the center pintle *c*, as seen in Fig. 2, and curves toward it, so as to have the rounded part of the end thereof touch the straight side of lever-arm G. *j'* is a spring, one of its ends fast to sliding arm *j*, and the other fast to arm G, in order to cause arm G to return with arm *j* in its backward reciprocations. K is a link, pivoted at one end to arm *j* of slide J, and the other end to arm H, so that as the rowlock is turned it imparts a horizontal sliding motion to the slide J, through arm H, link K, and arm *j* of the slide. L is a bracket firmly fixed upon the plate B, and rises upward, and then projects inward toward the rowlock and over the revolving wheel E. *l* is a friction-plate or shoe placed under the outer edge of wheel E, and against which it

bears, and beneath the bracket L. V is another friction-plate or shoe placed above, and bears upon the top edge of wheel E. m is a temper-screw working in the inwardly-projecting part of the bracket L, and bears upon a curved plate-spring, n , the ends of which rest upon the upper side of shoe V , so that by forcing the spring n down upon the shoe V the friction will be increased between the wheel E and the shoes l and V to any extent desired.

By the construction above described, the motion of the oarsmen, the oar, and the resistance upon the oar at all points of the stroke will be the same as if the oarsman were in a boat, and his boat in the water, and the oar took into the water, as when the stroke of the oar begins there is little resistance, as the arm on slide J is near to and bearing against the outer end of lever-arm G, while arm H and link K cause the slide J to move forward as the stroke advances, the arms j and G being kept in contact, but arm j continually advancing toward the center of motion of the rowlock, the length of leverage decreasing on arm G, until a half-stroke of the oar is performed; and when the oar is at, or nearly at, right angles with the imaginary boat, the oar then has its greatest resistance, the stroke advancing, and the slide-arm j begins slowly to reverse its position upon the lever-arm G, and go from the center of the rowlock increasing, the length of the leverage on arm G until the full stroke is completed, when the resistance is nearly or quite overcome, and the oarsman returns his oar to the position to commence the next stroke. As the arm G moves or partially revolves, the pawl or clutch-arm f takes against the wall of the sink in wheel E, and causes it to make a partial revolution. The resistance to the revolution of the wheel E is caused to be greater or less by the frictional contact of the rim of the wheel between the shoes l and V , and regulated by the temper-screw m , to produce the required resistance proportioned to the strength of the oarsman. The slide J

moves horizontally, the arm of which is in contact with the arm G, which moves in an arc of a circle around the center post or pintle c , causing the arm G to move a greater or less distance in a given time, for the reason that the power applied by arm j on slide J is applied at different parts of the stroke to the arm at points varying in length of leverage through every part of the stroke—that is, when the stroke commences the power is applied to the longest part of the lever, giving a light resistance, and as the stroke advances the leverage is constantly getting shorter, and the resistance greater, until the half-stroke is made, when the resistance is diminished by reason of the increase of the length of the leverage until the full stroke is completed, when little resistance exists, and the oar is free to return to repeat the stroke.

Having thus described my invention, what I claim, and desire to secure by Letters Patent, is—

1. The horizontal slide J, link K, and arm H, in combination with the rowlock C, as and for the purposes described.

2. The rowlock C, lever-arm H, link K, and horizontal reciprocating slide J, with arm j , in combination with the arm G and spring j' , constructed substantially as described, whereby a varying resistance is produced in the stroke of the oar.

3. The rowlock C, lever-arm H, link K, slide J, having arm j , arm G, and pivoted pawl or clutch-arm f , in combination with the revolving wheel E, substantially as and for the purpose described.

4. The bracket L, temper-screw m , spring-plate n , and shoes l and V , in combination with the revolving wheel E, substantially as and for the purposes described.

GEO. W. MOORE.

Witnesses:

M. H. KING,
M. F. SOWLEN.