

E. F. KITTOE & F. BROTHERHOOD.

Shaft for Ore-Washer.

No. 161,687.

Patented April 6, 1875.

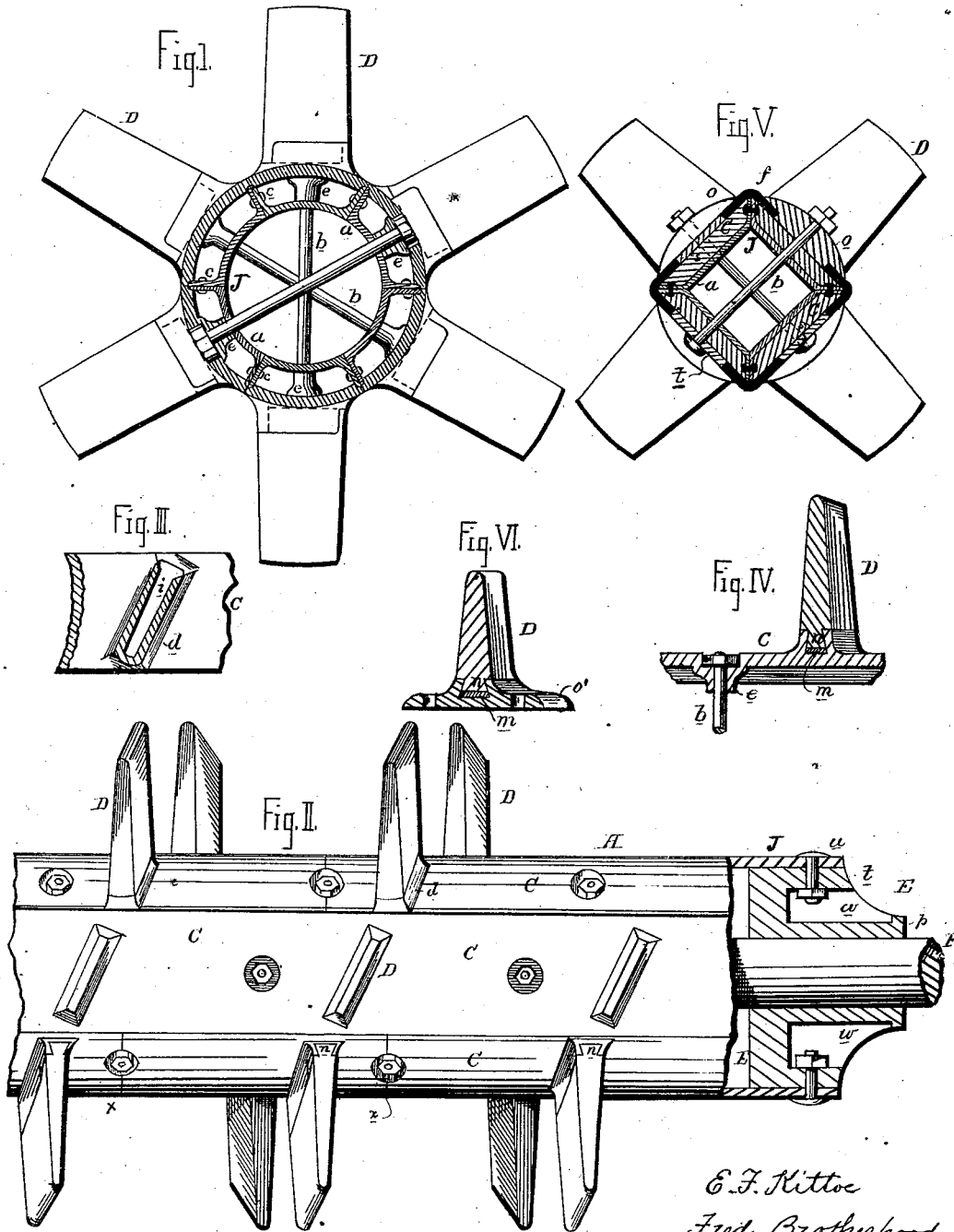

WITNESSES  
*C. M. Gallaher.*  
*J. H. Skidmore.*

*E. F. Kittoe*  
*Fred. Brotherhood*  
 INVENTORS

By \_\_\_\_\_  
*Houston & Co.*  
 their ATTORNEYS

# UNITED STATES PATENT OFFICE.

EDWARD F. KITTOE AND FRED BROTHERHOOD, OF CHARLESTON, S. C.

## IMPROVEMENT IN SHAFTS FOR ORE-WASHERS.

Specification forming part of Letters Patent No. 161,687, dated April 6, 1875; application filed March 9, 1875.

*To all whom it may concern:*

Be it known that we, EDWARD FREDERICK KITTOE and FRED BROTHERHOOD, of Charleston, county of Charleston, South Carolina, have invented an Improved Shaft for Ore-Washing and other Machines, of which the following is a specification:

The object of our invention is a shaft for ore-washing machines, pug-mills, &c., which shall be stronger, more rigid, and lighter in weight than those heretofore used, and to which the radial blades or arms may be readily applied; and this object I attain by constructing the shaft in the manner illustrated in the accompanying drawing, in which—

Figure 1 is a transverse section, showing one form of shaft made in accordance with our invention; Fig. 2, an exterior view, partly in section, of one end of the shaft; Figs. 3 and 4, detached views of parts of the shaft; and Figs. 5 and 6, views, showing a modification.

The stem J of the shaft is made by riveting together the flanges of a number of flanged metal strips, *a*, to form a tube with external longitudinal ribs *c*, such a tube being known as a "Phoenix Column."

The radiating arms or blades D are secured to the shaft between the ribs *c c*, being arranged, in the present instance, on a line winding spirally round the shaft. To facilitate the attachment of the blades to the shaft each blade may be secured to or form part of a block or strip of wood or metal, lying between or resting on the ribs *c c*, and divided into sections C C, which are arranged either at intervals with intervening spaces, or in contact with each other, as shown in Fig. 2. The blades are secured to the stem by bolts *b b*, each of which crosses the axis of the shaft and passes through the sections at opposite sides thereof.

When the sections are of metal the bolts pass through hollow lugs *e* at the inner sides of the sections, which lugs afford bearings for the sections upon the faces of the column, and also thicken the sections at these points, so that they may be countersunk to receive the heads and nuts of the bolts, which are, therefore, less liable to wear away than when exposed.

When the sections are of metal, dovetailed

sockets *i* may be formed therein to receive dovetailed ribs *n* of the blades or arms D, which may therefore be readily applied and removed, thin plates or strips being driven into the sockets, so as to wedge the blades in their places after adjustment, as shown in Fig. 4.

When metal sections are not used the blades are bolted directly to the stem between the ribs *c c*, or to wooden sections C C, lying between the ribs, as shown in Fig. 5. In this case each bolt passes through an opening in a flange, *o*, at one side of a tooth, through the stem, and through a thin metal washer or distance-piece, *t*, arranged between adjacent blades at the opposite side of the stem, thus securing both the sections and the teeth in their places.

Instead of forming the flanges *o* in one piece with the blades they may be made separate, with sockets to receive dovetailed ribs of detachable teeth, as shown in Fig. 6.

To prevent the access of water and grit below the wood sections, strips *f* of metal are arranged to cover each rib *c* and overlap the faces of the adjacent sections, Fig. 5, to which they are secured by screws or nails.

The shaft, constructed as described, is adapted to be used in pug-mills, mixing machines, &c., but is specially serviceable in ore-washing machines, owing to its rigidity and light weight, the ribs *c c* imparting great stiffness when comparatively thin metal is used for the plates *a*, and the bolt *b*, when used for securing the blades, imparting increased rigidity.

One of the most important results of the above-described construction of the shaft is the facility with which the blades may be arranged in any desired position, it only being necessary, in order to change them, to remove the bolts and again apply them after the readjustment of the blades.

It will be apparent that the hollow column or stem may be of any desired sectional form, and that the arrangement of the sections C may be altered, and the mode of securing the blades varied without departing from the main features of our invention.

We claim—

1. A shaft for ore-washing machines, &c., consisting of a tubular column, J, composed of

flanged plates *a*, riveted together at the edges, and blocks *D*, secured to the column between the ribs formed by the flanges, as set forth.

2. The combination, in a shaft for ore-washing machines, of a hollow ribbed column, *J*, sections *C*, confined to the column between the ribs, and blades *D*, secured to or forming part of said sections, as set forth.

3. The combination of the column *J*, blades *D*, and bolts *b*, passing through the column and securing the blades, as described.

In testimony whereof we have signed our names to this specification in the presence of two subscribing witnesses.

E. F. KITTOE.  
F. BROTHERHOOD.

Witnesses:

FREDERICK I. SMITH,  
W. M. AIKEN.