



C. H. PALMER.  
Sewing-Machine.

No. 161,895.

Patented April 13, 1875.

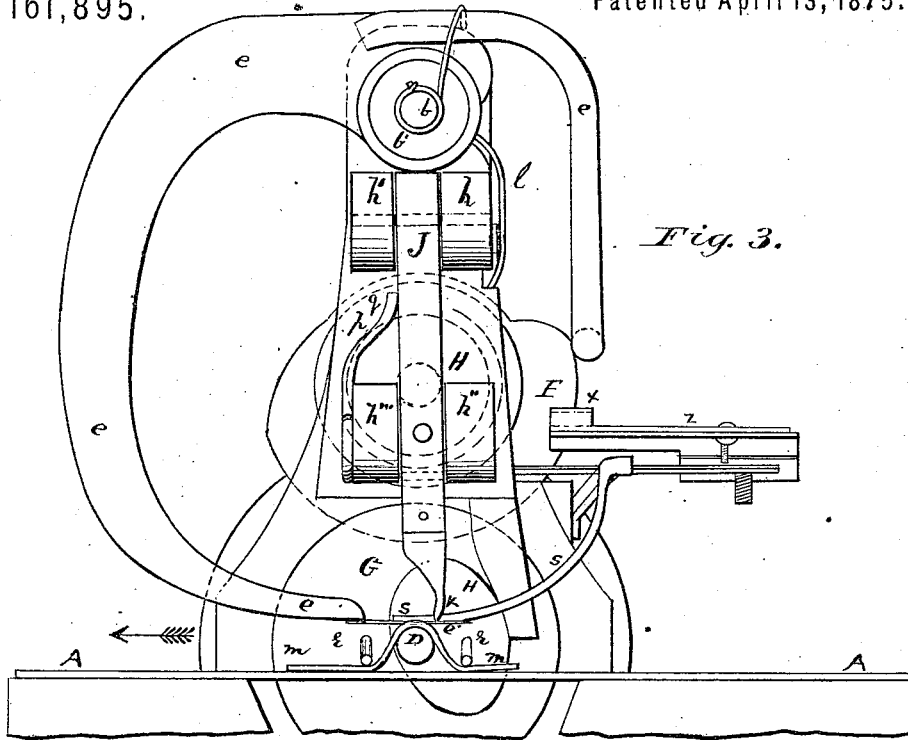

Fig. 3.

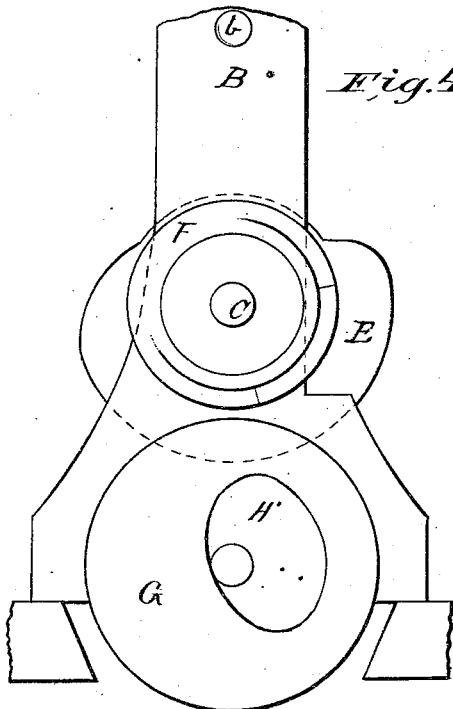

Fig. 4.

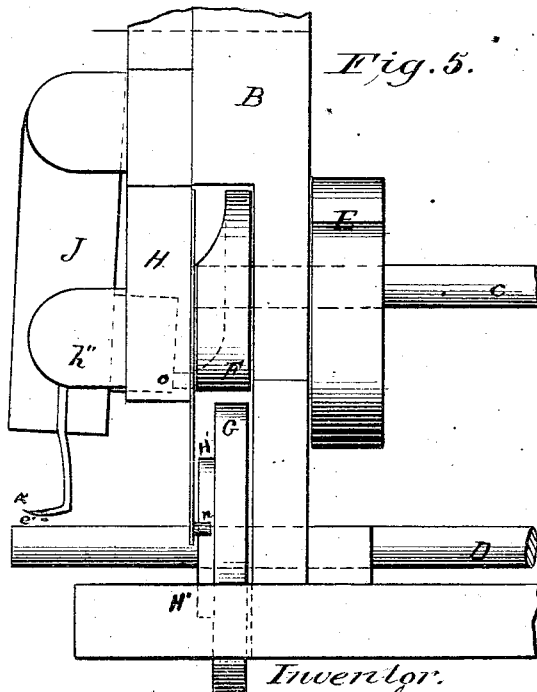

Fig. 5.

Witnesses:  
J. M. Hicks  
Luis Condit

Inventor:  
Charles H. Palmer  
by his Attorney  
J. M. Hicks

# UNITED STATES PATENT OFFICE.

CHARLES H. PALMER, OF NEW YORK, N. Y.

## IMPROVEMENT IN SEWING-MACHINES.

Specification forming part of Letters Patent No. **161,895**, dated April 13, 1875; application filed February 25, 1874.

*To all whom it may concern:*

Be it known that I, CHARLES H. PALMER, of the city, county, and State of New York, have invented a new and useful Improvement in Sewing-Machines; and I hereby declare that the following is a full, clear, and exact description and specification of the same, reference being had to the accompanying drawings, in which—

Figure 1 represents a side elevation. Fig. 2 is a top view of the frame which supports the guide S and gage z. Fig. 3 represents a front elevation of the machine. Fig. 4 is a front view of the standard B and the cams F and H' as they would appear with the parts in front removed. Fig. 5 is a side view of the standard B, cams E F H', pendulum-plate H, and lever J, for operating the loop-holder K.

The object of my invention is to furnish a practical and useful machine for sewing straw goods with a chain-stitch seam, formed by means of an ordinary eye-pointed machine-needle, nearly straight, which carries a loop of thread through the surface of the material, and again out of said surface, to be caught and held by a looping device, which is so operated, in connection with the holding and feeding mechanism, as to interloop the stitches; and to this end my invention consists in certain combinations of machinery, which are set forth specifically at the end of this schedule.

In order that persons skilled in the art may understand, make, and use my invention, I will proceed to describe said sewing-machine as I have constructed it.

Upon the platform or table A I attach two standards, B and B'. At right angles to these standards, and parallel with the surface of the table A, I place two small shafts, D and C, in bearings fitted for them in the standards. The lower shaft D is located near the surface of the table, and extends in front of the standard B beyond the needle far enough to support and feed the material to be sewed. It also extends beyond the standard B', to receive a gear, D', a grooved pulley, and balance-wheel. The shaft C also extends beyond the standard B', and is provided with a gear, C', which meshes into the teeth of gear D', thus causing both shafts to revolve at the same speed. On the front end of said shaft, and in front of the

standard B, is a cam, F, which is so shaped on its face, near its periphery, that it may give motion in the direction of the length of the shaft to the lever J by means of a stud-pin fastened to said lever, which passes through a hole in the pendulum-plate H, and is caused to ride over the configurations of the cam by the action of the spring p. Behind the standard B, on the shaft C, and revolving with it, is a cam, E, which is so shaped on its periphery as to give the proper motions to the needle-arm e, the spring b' forcing the end of the needle-arm near the cam to follow its configuration. The needle-arm e, as well as the pendulum-plate H, is pivoted to the standard B on the stud b, which is firmly fixed in B, and projects in front far enough to receive the spring b', coiled around it. The pendulum-plate H, hanging down from this stud, is caused to vibrate on it by means of the cam H on the face-plate G, driven by the shaft D, the pin n on an arm attached to H following its configuration under the pressure of the spring l. Attached to this pendulum-plate H are four guides, h h' h'' h'''. To the two upper ones h h' is pivoted a vibrating lever, J, the lower guides h'' h''' acting only as ways to confine the lever sidewise. To this lever J is connected the loop-catcher and finger K.

As the lever receives movement in one direction from the cam F, so also it receives the pendulum movement imparted to the plate H by the cam H', the two movements causing the loop-catcher to enter the loop, hold it, carry it into the path of the needle, and then release it. A portion of the exterior surface of the end of the shaft D is made rough, and, as it revolves, causes the material m m, held to the rough surface by the spring-fingers r r, to move toward the needle in the direction of the arrow, the material being bent over the shaft in the form of a curve, after the manner of hand-sewing, enabling the needle e', which is substantially straight, to pass through the surface of m twice—in other words, to enter the surface of the straw, pass forward, and then out from the same surface.

Attached to the standard B', and resting on standard B, is a bar, s, which is bent and carried down in front of the plate H, resting near the shaft D, to act as a guide for the braid of

straw to be sewed. Above this bar *s* is a plate, *w*, fastened by an adjusting-screw, *w'*, in the slot *x*. This plate *w* is shaped in the form of a letter **L**, the shorter arm extending toward the lever **J**, and being furnished with a lip, *x'*, forming one side of a gage, and with an adjustable lip, *x''*, pivoted to the plate at *Z'*, and fastened by the screw *Z''* in the slot. Between these lips the braid of straw is caused to pass on its way to the fingers *r r* and the feed portion of the shaft **D**, in order to guide it at any desired angle in shaping the hat or other article being made on the machine.

The operation of the machine is as follows: A braid of straw being placed under the needle, over the feed portion of shaft **D**, and under the fingers *r r*, the needle *e'* is threaded with a suitable thread, drawn from a spool located on some convenient portion of the machine, and, in some convenient manner well known to sewing-machine operators, furnished with proper tension, the shaft **D** is caused to revolve, which carries with it the cam **H'**, and, through the gears **D'** and **C'**, causes the shaft **C** to revolve in the opposite direction, carrying the cams **E** and **F**. The spring *l* presses the end of the needle-arm toward the cam **E**, and the needle *e'* enters the straw-braid and passes through until the eye comes out of the surface, when, by a slight retraction, a loop is formed. The loop-catcher **K** now advances into the loop by the action of cam **F**, and holds it until the needle has retreated, when it is carried in the same direction with the needle, and holds the loop in such position that the needle may enter it on its next advance toward the material to be sewed. The needle now advances into the loop and pierces the straw at a new point, the feed device on the

end of the shaft **D** having moved it forward, and the loop-holder recedes and returns it to its former position, ready to catch another loop. Thus a seam is formed, with single-thread loops passing twice through the straw surface, without the necessity of giving a sharp curvature to the needle, the manner of holding, feeding, and guiding the straw-braid enabling the machine to operate a needle nearly straight, and making a very practical and useful machine.

If desired, the braid may be passed through the gage, and directed in such a manner as to supply it to a hat or other article being made at the proper angle, thus materially assisting the operator in the sewing.

Having now fully described my machine, and the manner in which I use it, what I claim as my invention, and desire to secure by Letters Patent, is—

1. The combination, substantially as before set forth, of the holding and feeding mechanism, the loop catcher and holder, and the pendulum-plate with the needle-lever swinging in the arc of a circle, and arranged to give the needle a movement nearly parallel with the surface of the table, all operating together to form a chain-stitch single-thread seam, as set forth.

2. The combination of the adjustable gage, attached to the guide-frame above the table, substantially as described, and the guide, extending from said frame to the feed-roll, both for directing and controlling the straw-braid, as set forth.

CHARLES H. PALMER.

Witnesses:

HARSEN H. SMITH,  
MARY P. CARPENTER.