

F. M. COVELL.  
Circular Saw-Mill.

No. 161,935.

Patented April 13, 1875.

Fig. 1.

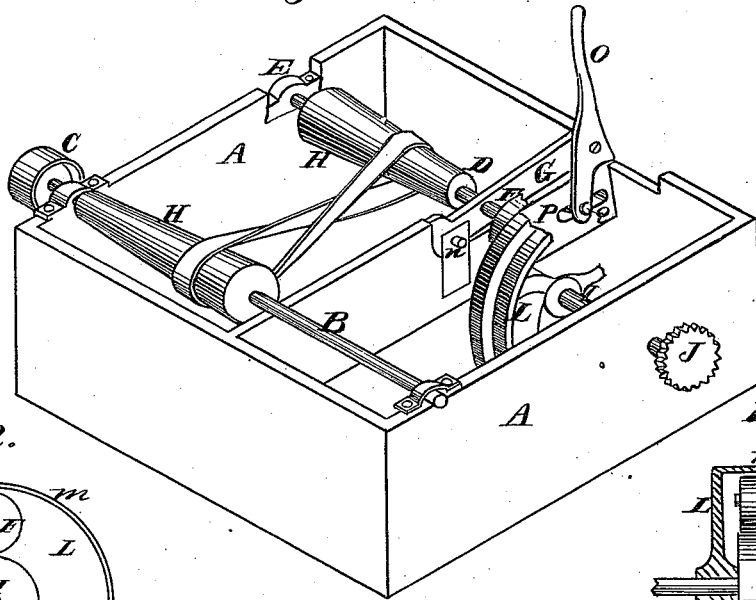

Fig. 2.

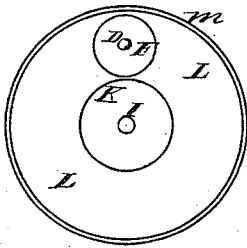

Fig. 3.

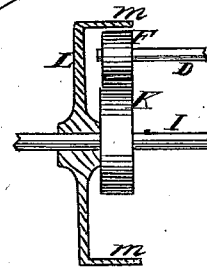
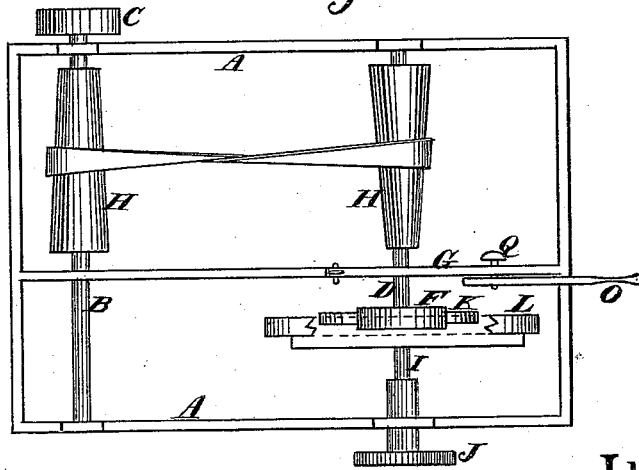

Fig. 4.



Witnesses

*Wm. L. Bone*  
*C. M. Richardson*

Inventor

*Frank M. Covell*  
*by Dewey & Co.*  
*Attys*

# UNITED STATES PATENT OFFICE.

FRANK MARION COVELL, OF LOS GATOS, CALIFORNIA.

## IMPROVEMENT IN CIRCULAR-SAW MILLS.

Specification forming part of Letters Patent No. 161,935, dated April 13, 1875; application filed November 28, 1874.

*To all whom it may concern:*

Be it known that I, FRANK M. COVELL, of Los Gatos, Santa Clara county, State of California, have invented an Improvement in Circular-Saw Mills; and I do hereby declare the following description and accompanying drawings are sufficient to enable any person skilled in the art or science to which it most nearly appertains to make and use my said invention without further invention or experiment.

My invention relates to an improvement in that class of forward and reverse mechanism for saw-mill carriages which operate by means of friction devices, consisting in the use of a small pulley so mounted upon a shaft that it stands between the outer face of a small pulley and the inner face of a large pulley, mounted upon one shaft, and by moving this small pulley a short distance in either direction it can be brought in contact with either of these faces, thus giving motion in either direction to the shaft of the double pulley. My invention also relates to a novel method of mounting the movable pulley-shaft, and a lever by which it is thrown into contact with one pulley-face or the other.

Referring to the accompanying drawing for a more complete explanation of my invention, Figure 1 is a perspective view of my gear. Figs. 2 and 3 are enlarged views of the frictional device. Fig. 4 is a plan view.

A is the frame upon which the machinery is mounted. The arbor B extends across one end of this frame, and is driven by a belt-pulley, C. Parallel with this arbor is placed the shaft D, one end of which is supported in a box, E, which may be so mounted as to have a limited swiveling motion, so as to accommodate it to the movements of the shaft D. The other end of this shaft carries the small friction-pulley F, and near this end the shaft turns in a box upon the movable arm or lever G. Motion is given to this shaft by means of a belt passing between the two cone-pulleys H H upon the shafts B and D. In a line below the pulley F is mounted a shaft, I, upon the end of which is secured the pinion J, which meshes into the rack upon the saw-mill carriage, for the purpose of driving it forward or back. Upon the shaft I a pulley, K, is se-

cured just beneath the pulley F, so that the latter can be brought into contact with it by depressing the shaft D. Another pulley, L, is also secured to the shaft I, so that its rim or flange *m* will overhang the pulley F, and at a little distance above it.

By this construction, it will be seen that the pulley F can be moved into contact with either the pulley K or L, or may be allowed to stand out of contact between them by very slightly moving the shaft D.

It will also be seen that when the pulley F is in contact with the inner face of the rim *m* it will give the shaft I a slow motion for the forward feed of the log-carriage, and when it is brought into contact with the outer face of the smaller pulley K it will give a more rapid motion in the opposite direction for the reverse movement of the carriage.

In order to operate the shaft D and move the pulley F up and down, the shaft passes through the arm G, one end of which is hinged or pivoted at *n*. The other end is pivoted to a lever, O. The lower end of this lever extends down beside the frame-work A, through which a horizontal slot, P, is made, and a pin, Q, passes through the slot and into the lever, so that when the handle of the lever is pushed forward the arm G will be raised, and when it is drawn back the arm will be depressed, thus giving a corresponding motion to the shaft and pulley.

By this device I am enabled to operate the carriage with a greatly-simplified mechanism.

Having thus described my invention, what I claim, and desire to secure by Letters Patent, is—

In combination with the pulleys K and L, mounted upon one shaft, and the movable shaft D, with its pulley F, the cone-pulleys H H, the arm G, pivoted as shown, together with the lever O, with its pin Q, moving in the slot P, substantially as and for the purpose herein described.

In witness whereof I hereunto set my hand and seal.

FRANK MARION COVELL. [L. s.]

Witnesses:

J. W. LYNDON,  
MORGAN COVELL.