

J. G. BAKER.
 Manufacture of Iron Mill-Burrs.

No. 162,008.

Patented April 13, 1875.

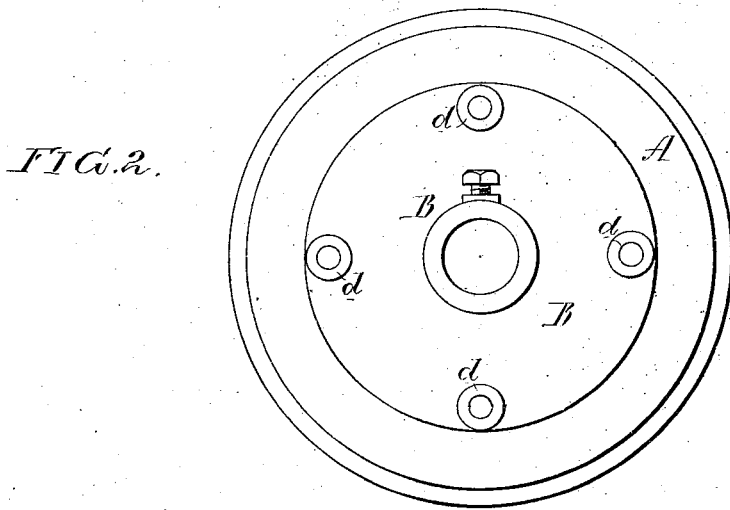
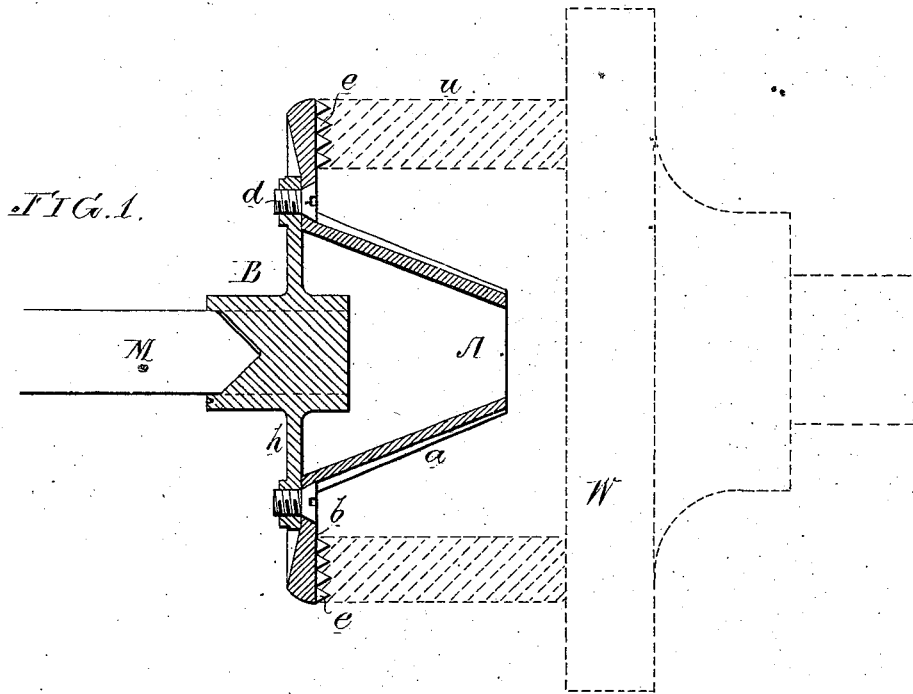

Witnesses, Hubert Howson
 Thomas McKeown

John G. Baker
 by his Atty.
 Howson and Son

UNITED STATES PATENT OFFICE.

JOHN G. BAKER, OF PHILADELPHIA, PA., ASSIGNOR TO ENTERPRISE MANUFACTURING COMPANY OF PENNSYLVANIA, OF SAME PLACE.

IMPROVEMENT IN THE MANUFACTURE OF IRON MILL-BURRS.

Specification forming part of Letters Patent No. 162,008, dated April 13, 1875; application filed February 16, 1875.

To all whom it may concern:

Be it known that I, JOHN G. BAKER, of Philadelphia, Pennsylvania, have invented certain Improvements in the Manufacture of Burrs for Grinding-Mills, of which the following is a specification:

My invention relates to the construction of the metal burrs of mills for grinding coffee, drugs, &c.; and the object of my invention is to so construct a burr, with a soft-metal hub and a hard-metal grinding-surface, that the truth of the latter, in respect to the spindle, shall be insured. This object I attain in the manner I will now proceed to describe, reference being had to the accompanying drawing, in which—

Figure 1 is a vertical section of my improved burr for grinding-mills, and Fig. 2 a rear view.

It is important in a mill of this class that the grinding-surface of the burr should be of the hardest metal; but the difficulty has been that hard cast-iron resists the action of the boring-tool required to prepare the burr for proper attachment to the mill-spindle. In order to overcome this difficulty, I make the burr of two parts, namely—the grinding portion A and hub B, the former being of cast-iron so hard as to resist the action of ordinary cutting-tools, and the latter being of comparatively soft metal, so that it can be readily bored for the reception of the spindle. The burr, as usual in mills of this class, has two grinding-surfaces—namely, the conical portion *a*, with coarse teeth, and the flat portion *b*, with annular rows of fine grinding-teeth *c*.

It is essential that, whatever means be adopted for securing the two burrs together, there should be no necessity for resorting to any tools for preparing the hard grinding portion for attachment to the hub; hence countersunk holes are formed in the said hard portion during the process of casting the same, for the reception of the beveled heads of the screws *d*, which are adapted to threaded holes in the flange *h* of the hub. Bolts may be substituted for the screws, or the heads of bolts may be embedded in the hard-metal

portion A during the process of casting the same, the latter plan obviating the necessity of using tools on the hard metal.

The two parts of the burr having been properly secured together, the next operation is to bore in the hub, for the reception of the mill-spindle, a hole which shall be true in respect to the grinding-surface of the portion A. In order to insure this I chuck the burr, with the hub attached, to the face-plate W of a lathe, as shown by dotted lines in Fig. 1; this face-plate having an annular projection, *w*, on the outer edge of which are one or more V-shaped rings, adapted to the annular V-shaped grooves between the teeth *e* of the flat grinding-surface. By means of an ordinary drilling-tool, M, and by causing the face-plate with the burr to revolve, I bore in the soft-metal hub B a hole for the reception of the mill-spindle. The chuck being true, and the drilling-tool in line with the center of rotation of the chuck, the face of which is at right angles to the said line, it necessarily follows that the hole bored in the hub must be at right angles to the flat grinding-surface, and that the spindle, when driven into the hole, must be true in respect to the said grinding-surface.

It will be understood that the bed-plate of a drilling-machine may have the annular projection *w* adapted to the flat grinding-surface, and the hole bored by a revolving drill, with a result similar to that above described.

I claim as my invention—

The mode herein described of preparing the hard-metal burr of a grinding-mill for attachment to the mill-spindle—that is to say, first securing the burr to a soft-metal hub, B, and then boring the latter while the burr is confined to a chuck of a lathe or bed of a drilling-machine adapted to the grinding-surface of the said burr, all as set forth.

In testimony whereof I have signed my name to this specification in the presence of two subscribing witnesses.

JOHN G. BAKER.

Witnesses:

HUBERT HOWSON,
HARRY SMITH.