

J. C. CLIME.
Roundabout.

No. 162,032.

Patented April 13, 1875.

FIG. 1

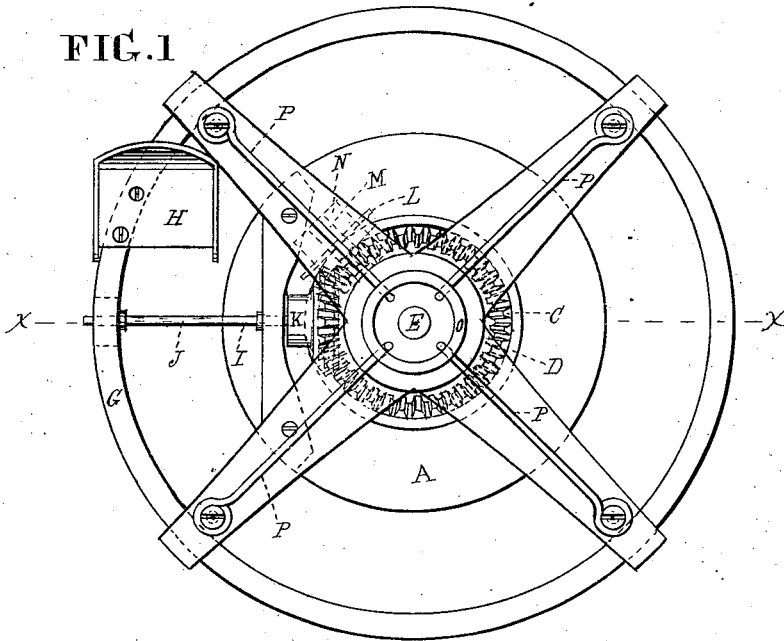
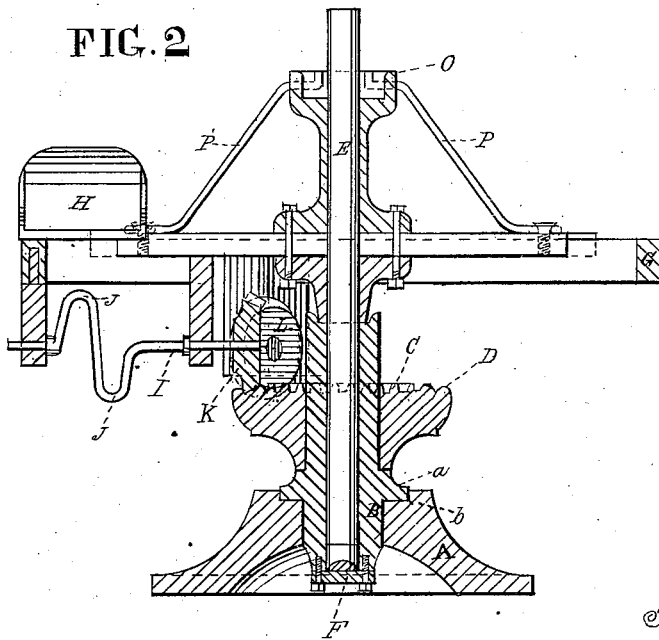

FIG. 2



Witnesses.
Thomas J. Dewey.
George C. Ketzner.

Inventor
John C. Clime
By His Attorney
Stephen W. Wick

UNITED STATES PATENT OFFICE.

JOHN C. CLIME, OF PHILADELPHIA, PA., ASSIGNOR OF TWO-THIRDS HIS
RIGHT TO JONATHAN C. CLIME AND JOSEPH LING, OF SAME PLACE.

IMPROVEMENT IN ROUNDABOUTS.

Specification forming part of Letters Patent No. **162,032**, dated April 13, 1875; application filed
January 9, 1875.

To all whom it may concern:

Be it known that I, JOHN C. CLIME, of the city and county of Philadelphia, in the State of Pennsylvania, have invented an Improvement in Revolving Pleasure-Carriages, of which the following is a specification:

My invention consists of a revolving carriage having one or more shafts provided with treadle-cranks, and also pinions which gear into a stationary bevel-wheel, which has a circular railway cast therewith, on which friction-wheels of the carriage revolve. The carriage is fast on a central shaft, the lower end of which revolves in a hub, which extends through the base of the machine and hub of the gear-wheels.

In the accompanying drawings, Figure 1 is a plan view of my improved pleasure-carriage. Fig. 2 is a vertical section at the line *x x* of Fig. 1.

Like letters of reference in both figures indicate the same parts.

A is the base of the machine. B is a hub, the lower end of which extends down through the center of the base, and the flange *a* rests in the recess *b* of the same, and is confined by means of bolts. C is a bevel-gear wheel, having a circular railway, D, cast therewith. The wheel is situated on the hub B and rests upon the flange *a* of the latter, and is fastened thereto by means of screws or bolts. E is a central shaft, the lower end of which revolves in the central opening of the hub B, and rests upon the adjustable step F, at the lower end of the hub. G is the carriage, which is secured fast to the shaft E. It has any desirable number of seats, H, for the riders, and

one or more shafts, I, that have treadle-cranks J, operated by the riders. The shafts are provided with pinions K, which gear into the bevel-wheel C, whereby the carriage is revolved. To relieve the step F and the gearing of a large amount of friction, the carriage G is provided with one or more friction-wheels, L, that revolve on the circular railway D. The shafts M of the wheels are supported by means of hangers N, which project from the lower side of the wheel. To give strength and support to the carriage, there is a rim, O, connected with the shaft E, at the upper end of the hub B, with which the upper ends of stay-rods P are hooked, the lower ends of the rods being turned to form eyes for connecting them to the carriage by means of screws.

I claim as my invention—

1. The revolving pleasure-carriage G, permanently connected with the upper end of the revolving shaft E, in combination with the base A, having a central hub, B, in which the lower end of the shaft E revolves, the said hub being provided with a bevel-gear wheel, C, having a circular railway, D, cast therewith for the support of the carriage, substantially as set forth.

2. The combination of the revolving pleasure-carriage G, having shafts I, provided with treadles J and pinions K, with the bevel-gear wheel C and circular railway D, substantially as and for the purpose set forth.

JOHN C. CLIME.

Witnesses:

THOMAS J. BEWLEY,
STEPHEN USTICK.