

R. CRAMER.

Nut-Lock.

No. 162,036.

Patented April 13, 1875.

*Fig. 1.*

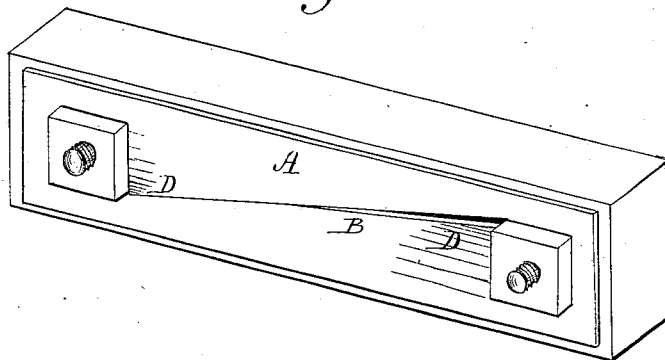

*Fig. 2.*

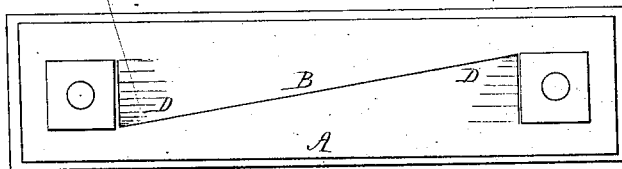

WITNESSES  
*A. Van Arsdale*  
*Joseph Shinn*

By

INVENTOR  
*Reuben Cramer*  
*Per Parker H. Sweet, Jr.*  
Associate Attorney

# UNITED STATES PATENT OFFICE.

REUBEN CRAMER, OF PITTSBURG, PENNSYLVANIA.

## IMPROVEMENT IN NUT-LOCKS.

Specification forming part of Letters Patent No. **162,036**, dated April 13, 1865; application filed March 2, 1875.

*To all whom it may concern:*

Be it known that I, REUBEN CRAMER, of Pittsburg, in the county of Allegheny and State of Pennsylvania, have invented a new and useful Improvement in Nut-Lock; and I do hereby declare that the following is a full and exact description thereof, reference being had to the accompanying drawing and to the letters of reference marked thereon.

My invention relates to an improvement in nut-lock, and consists in the use of a thin plate of iron having a Z-shaped cut in it, said plate being used, in combination with the ordinary bolts, nuts, and fish-bars of railway-joints, for the purpose of holding the nuts in position upon the bolts.

To enable others skilled in the art to make and use my invention, I will proceed to describe its construction and operation.

In the accompanying drawings, which form part of my specification, Figure 1 is a face view of the plate, provided with a Z-shaped cut through it. Fig. 2 represents the plate placed in juxtaposition with the bolts, nuts, and fish-bars, forming joints in railways. Fig. 3 is a transverse section of the plate at line *y* of Fig. 1, with the points D sprung out, as when holding the nut.

A represents the plate, which may be of any desired thickness and width, and may be constructed of wrought-iron or of steel. B represents the Z-shaped cut extending through it, said cut being formed through the medium of suitable tool or tools. C represents openings for the bolts.

When the plate is in position for holding the nuts, as represented in Fig. 2, the points D will spring out so as to project out on the side of the nut, as represented in Fig. 2, thereby holding the nuts in a fixed position. When it is desirable to remove the nuts off the bolts, the points D are pressed toward the fish-bars and rail, so as to allow the nut to be turned upon its bolt.

Having thus described my improvement, what I claim as of my invention is—

The plate A, provided with openings C and a Z-shaped cut through it, in combination with the bolts, nuts, and fish-bars of railway-joints, substantially as herein described, and for the purpose set forth.

REUBEN CRAMER.

Witnesses:

A. C. JOHNSTON,  
B. L. JOHNSTON.