

J. HARRINGTON.
Screw-Propeller.

No. 162,063.

Patented April 13, 1875.

Fig 1

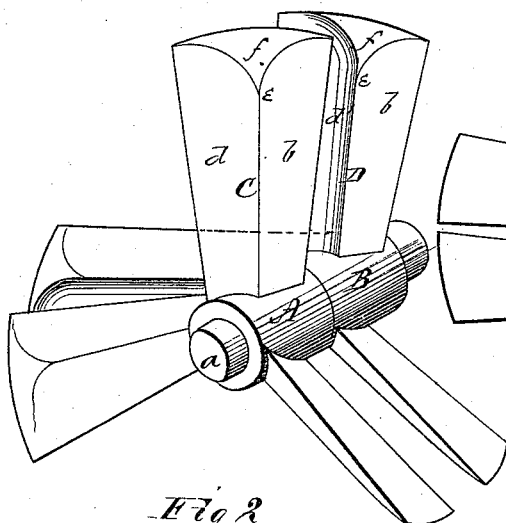

Fig 3

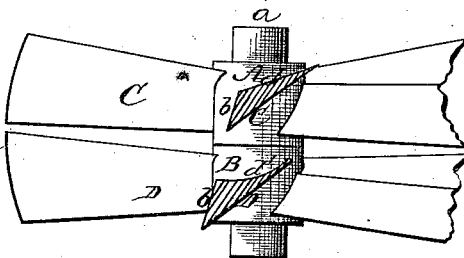
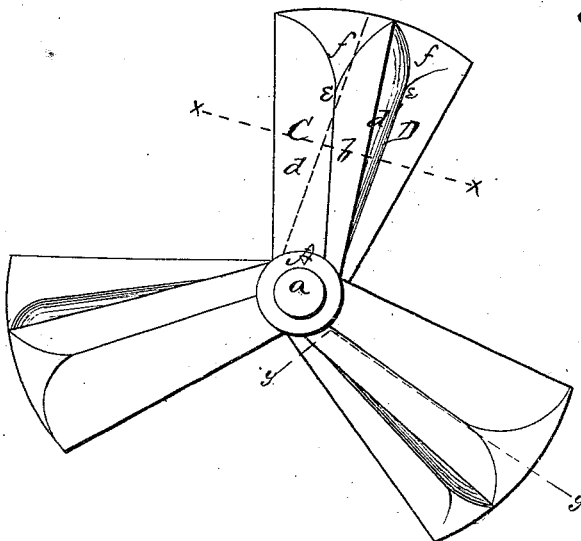
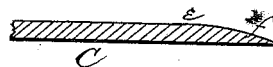

Fig 2

Fig 4



WITNESSES
F. L. Ourand
C. L. Ewert

INVENTOR
Jackson Harrington
per Alexander MacArthur
ATTORNEYS

UNITED STATES PATENT OFFICE.

JACKSON HARRINGTON, OF GROTON BANK, CONNECTICUT, ASSIGNOR OF
ONE-HALF HIS RIGHT TO FRANKLIN P. RENYON.

IMPROVEMENT IN SCREW-PROPELLERS.

Specification forming part of Letters Patent No. **162,063**, dated April 13, 1875; application filed
December 19, 1874.

To all whom it may concern:

Be it known that I, JACKSON HARRINGTON, of Groton Bank, in the county of New London and in the State of Connecticut, have invented certain new and useful Improvements in Propeller-Wheels; and do hereby declare that the following is a full, clear, and exact description thereof, reference being had to the accompanying drawings and to the letters of reference marked thereon, making a part of this specification.

My invention is intended as an improvement upon the Letters Patent No. 53,297, dated March 20, 1866; and it consists in the construction and arrangement of a propeller wheel, as will be hereinafter more fully set forth.

In order to enable others skilled in the art to which my invention appertains to make and use the same, I will now proceed to describe its construction and operation, referring to the annexed drawing, in which—

Figure 1 is a perspective view of my propeller-wheel. Fig. 2 is a front view of the wheel. Fig. 3 is a plan view, with a section of two of the blades, being in section through the line $x x$, Fig. 2. Fig. 4 is a longitudinal section of one of the blades through the line $y y$, Fig. 2.

The wheel is composed of two collars, A and B, keyed or otherwise secured on a shaft, a . The collar A is provided with three or more radiating blades, C C, and the collar B is also provided with three or more blades, D D. The collar A is placed in advance of the collar B on the shaft a , and all the blades are set at an inclination, and the front blades C C being set so as to be in advance of their respective rear blades D D, and cutting the water in advance of them. The rear sides of all the blades are perfectly flat, and in each set or pair of blades said flat sides are parallel with each other. The front of the forward blade C forms two inclined sides, $b d$, and forming a ridge longitudinally with the blade from the collar or hub A to a point, e , and from this point to the outer edge the blade is beveled, as shown at f . The fronts of the rear blades

D are formed in the same manner, with the exception that the inclined side d is made concave, as shown particularly in Fig. 3, said concave being marked d' . The inclined sides b are made narrower than the inclined sides d , so that the strength of the blade is preserved, while giving a sharper angle for the passage of the blade into the water, thereby creating but little friction, and to a great extent preventing the reaction of water.

In operation, the concaved sides d' permit the water to pass off without choking—that is to say, by making the face d' concaved, the requisite strength of the blade is preserved, while providing a free channel or passage between the front and rear blades.

By constructing the wheel with two separate collars or hubs, each with its respective blades, it can be manufactured easier and at a less cost than if made of one piece, and the hubs may be separated on the shaft, so as to place the blades at any desired distance apart, while the angle of the blades always remains the same.

Having thus fully described my invention, what I claim as new, and desire to secure by Letters Patent, is—

1. A propeller-wheel consisting of two separate and independent hubs, each provided with a series of radiating blades set at an angle, and so arranged that the edge of the forward blades shall be in advance of the rear ones, substantially as herein shown and described.

2. The blades C C, constructed, as described, with the inclined sides $b d$, of unequal length, and bevel f , as herein set forth.

3. The blades D D, constructed, as described, with inclined side b , concave side d' , and bevel f , as herein set forth.

In testimony that I claim the foregoing I have hereunto set my hand this 11th day of December, 1874.

JACKSON HARRINGTON.

Witnesses:

J. TYLER POWELL,
C. L. EVERT.