

C. MILLER.  
Buggy-Top.

No. 162,089.

Patented April 13, 1875.

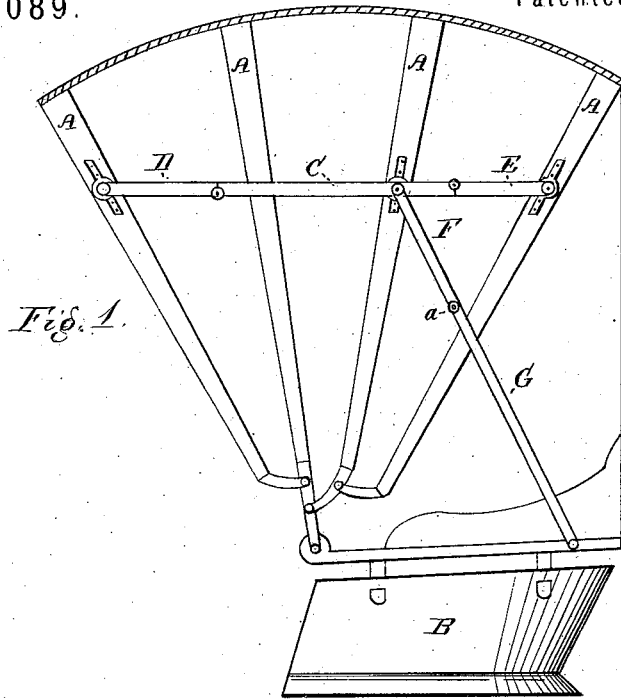

Fig. 1.

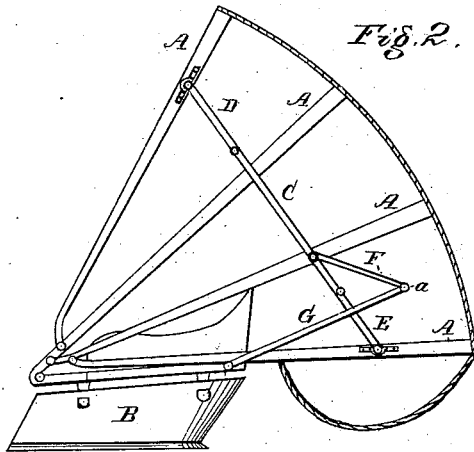

Fig. 2.

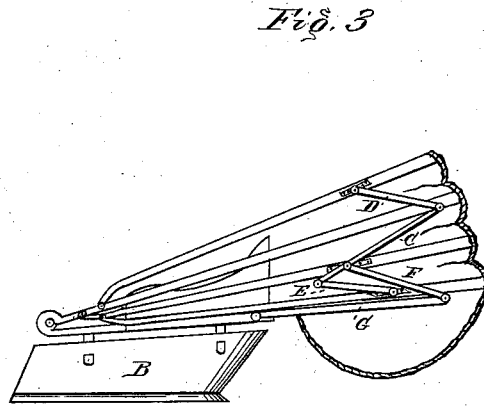

Fig. 3.

WITNESSES

*Wm. E. Cliphart*  
*Chas. H. Gill*

INVENTOR

*Charles Miller*  
*per Chas. H. Fowler,*

Attorney

# UNITED STATES PATENT OFFICE

CHARLES MILLER, OF FREMONT, OHIO.

## IMPROVEMENT IN BUGGY-TOPS.

Specification forming part of Letters Patent No. **162,089**, dated April 13, 1875; application filed August 17, 1874.

*To all whom it may concern:*

Be it known that I, CHARLES MILLER, of Fremont, Sandusky county and State of Ohio, have invented certain new and useful Improvements in Buggy-Tops; and I do hereby declare that the following is a full, clear, and exact description of the same, reference being had to the accompanying drawings and to the letters of reference marked thereon, in which—

Figure 1 is a side view of my improved buggy-top with a part of the canvas covering removed. Fig. 2 is a side view of the same, showing the top swung over; and Fig. 3 a similar view of the buggy-top when folded.

This invention has relation to buggy-tops; and consists in forming the center brace, which connects the two end braces of one solid piece, so that you can fold the top by breaking both joints simultaneously, and also admits of the top being let down, when desired, without folding the bows, as will be hereinafter more fully set forth.

In the drawings, A is designed to represent the bows of the carriage or buggy top, of the usual construction, and connected to each other, as shown in the drawings, and B represents the seat. C is the center horizontal brace, of one solid piece, the same being pivoted at one end to the bow A, and jointed

to the end braces D and E, which in turn are jointed to the front and rear bows of the buggy-top. Pivoted to the center horizontal brace C, at a point where it is joined to the bow A, is an upright brace, F, which connects a similar brace, G, at the joint *a*. These perpendicular or upright braces hold the top in an upright position, and by unseating the joint *a* the top turns back, as shown in Fig. 2, without closing the bows A, and thereby injuring the canvas covering, and by unseating the joints of the horizontal braces the top will be folded down, as shown in Fig. 3.

I am aware that means have heretofore been employed by which the top may be turned back without folding the bows to prevent injuring the covering of the carriage-top. I do not therefore claim, broadly, any means whereby such result may be accomplished; but

What I do claim, and desire to secure by Letters Patent, is—

The solid middle horizontal brace C, connected to the bow A, and to the braces D E, and the upright braces F G, all combined to operate as and for the purpose specified.

CHARLES MILLER.

Witnesses:

M. E. TYLER,  
JAS. S. VAN VALKENBURGH.