

J. W. ROBARDS.
Sewing-Machine Hemmer.

No. 162,102.

Patented April 13, 1875.

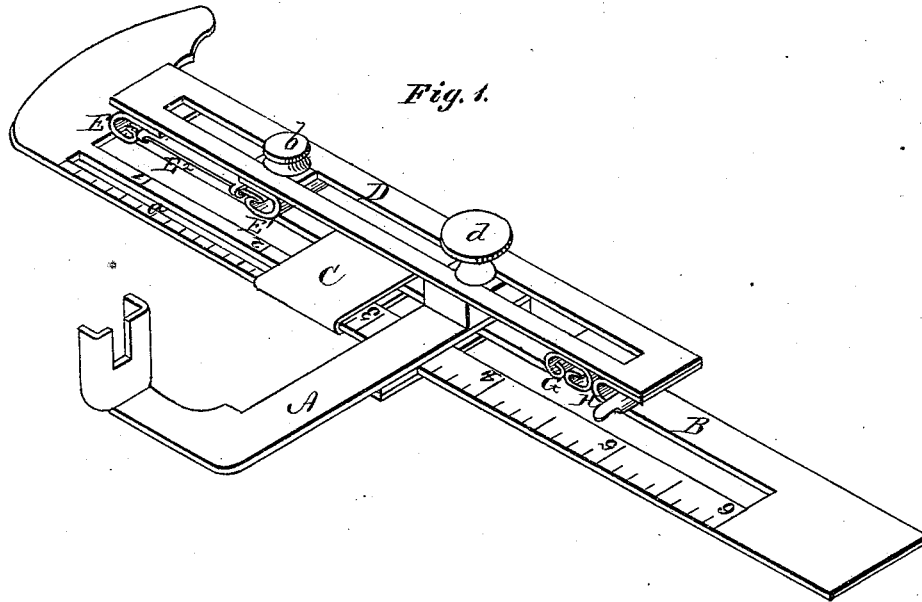

Fig. 1.

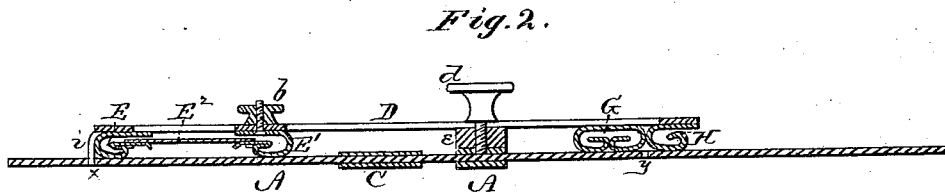

Fig. 2.

WITNESSES

Henry N. Miller
C. L. Eubank,

J. W. Robards INVENTOR
per Alexander Mason
ATTORNEYS

UNITED STATES PATENT OFFICE.

JOSEPH W. ROBARDS, OF RICHMOND, VIRGINIA.

IMPROVEMENT IN SEWING-MACHINE HEMMERS.

Specification forming part of Letters Patent No. 162,102, dated April 13, 1875; application filed January 20, 1875.

To all whom it may concern:

Be it known that I, JOSEPH W. ROBARDS, of Richmond, in the county of Henrico and in the State of Virginia, have invented certain new and useful Improvements in Sewing-Machine Hemmers; and do hereby declare that the following is a full, clear, and exact description thereof, reference being had to the accompanying drawings and to the letters of reference marked thereon, making a part of this specification.

My present invention is intended as an improvement upon the sewing-machine attachment for which Letters Patent, No. 155,976, were granted to me October 13, 1874; and the nature of my invention consists in the construction and arrangement of a hemmer to be used with said attachment, as will be hereinafter more fully set forth.

In the annexed drawing, Figure 1 is a perspective view of my invention; and Fig. 2 is a longitudinal section of the same.

A represents the L-shaped arm, B the slotted gage-plate, and C the slide thereon, all the same as described in my former patent, above referred to. D represents a longitudinally-slotted gage or plate, provided on its under side at one end with two small hemmers, E E', for turning both raw edges at the same time, and, by passing through the short slot *a* in the gage-plate B, creasing them at the same time. The hemmer E is stationary and the hemmer E' is adjustably connected thereto by a movable slide, E², and regulated by a set-screw, *b*, in order to make the distance between them wide or narrow, as the case may require. At the other end of the plate D is a double hemmer, G, and a single hemmer, H, both being permanently attached to the plate. The narrow double hemmer G is used for putting on a very narrow raw-edge trimming, turning both edges and creasing, as above described, in order to avoid the necessity of turning under and basting with the hand. The plate or gage D is adjusted and fastened by means of a set-screw, *d*, passing through the slot in the plate, and into and through a nut, *e*, formed on the arm A, which screw also holds the plate B in place.

This attachment is used with the ordinary plain presser-foot of a sewing-machine, the arm A being attached to the presser-foot arm in any suitable manner. The slotted arm D is turned and adjusted so as to bring the single hemmer H in a line with the needle, and the long gage B adjusted to make the width of hem desired, the parts being then fastened together and to the machine by the set-screw *d*. The attachment is then in position for ordinary hemming in the usual manner. The attachment can be changed to different kinds of work, namely, hemming different widths, putting on plain smooth-edge trimming different widths, and also raw-edge trimming different widths, turning both edges and creasing at the same time, also stitching one edge, all without basting, by simply turning the set-screw *d* and turning the plate D around to suit the different kinds of work without moving it from the machine, one screw governing all. Near the end of the gage B is a small hole, *x*, which is intended for the teat or pin *i* on the hemmer E to enter when using the raw-edge trimmer, in order to keep it in place, and the slide C on the gage B must be brought up by the side of the trimmer in order to keep trimming in a straight line with the needle, so that it will not strike too far from the edge. Near the other end of the gage B is another hole, *y*, for the teat *i* to fit in when using the very narrow double hemmer G and the slide C, brought up as described. When using it for smooth-edge trimming the gage or plate D is turned and fastened straight with the arm, the long gage B adjusted to the width desired, and the screw *d* tightened which holds both in their proper places. The two hemmers can be adjusted so as to make several widths by having the connecting-slide E² longer or shorter.

Having thus fully described my invention, what I claim as new, and desire to secure by Letters Patent, is—

1. In combination with the arm A, slotted plate B, and slide C, the slotted gage D, the stationary hemmer E, the adjustable hemmer E', movable slide E², and set-screw *b*, all substantially as set forth.

2. The combination of the arm A, the slotted plate B, having holes *x y*, the slotted adjustable gage D, the hemmer E, having teeth *i*, and the hemmers G¹ H, arranged as described, whereby either of the hemmers may be brought in proper position for use, all substantially as set forth.

In testimony that I claim the foregoing I have hereunto set my hand this 10th day of November, 1874.

JOS. W. ROBARDS.

Witnesses:

C. L. EVERT,
F. L. OURAND.