

F. GOULET.

Gage-Lathe for Turning Wood.

No. 162,229.

Patented April 20, 1875.

Fig. 1.

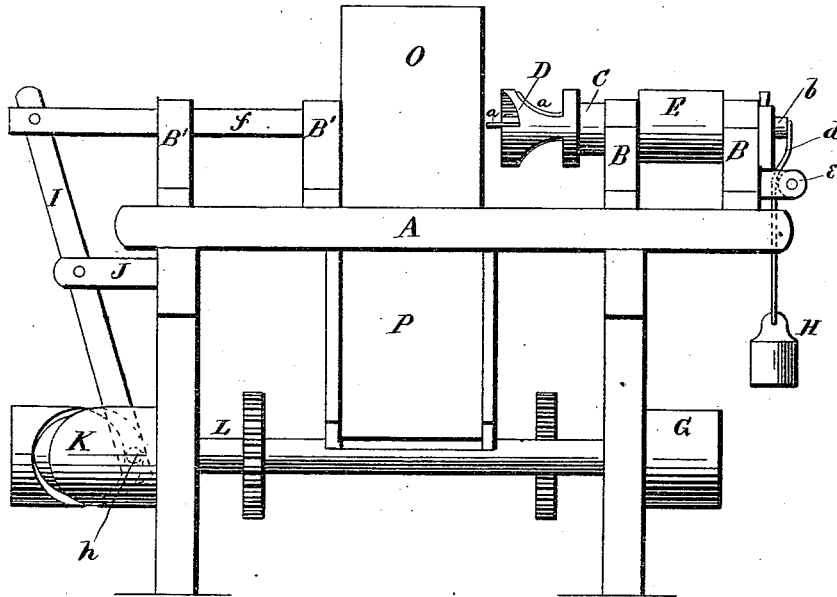
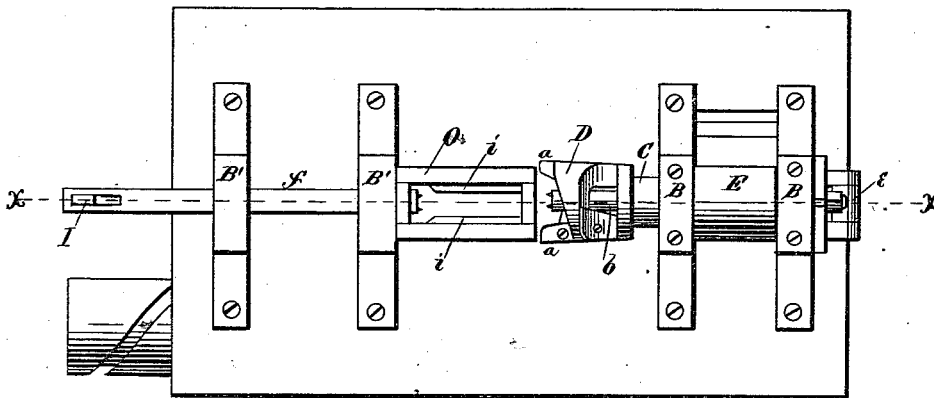

Fig. 2.



Witnesses:
W. S. Du Hamel
Thomas Byrne

Inventor
Felix Goulet
Per H. A. H. A. H.
 Attorney

F. GOULET.

Gage-Lathe for Turning Wood.

No. 162,229.

Patented April 20, 1875.

Fig. 3.

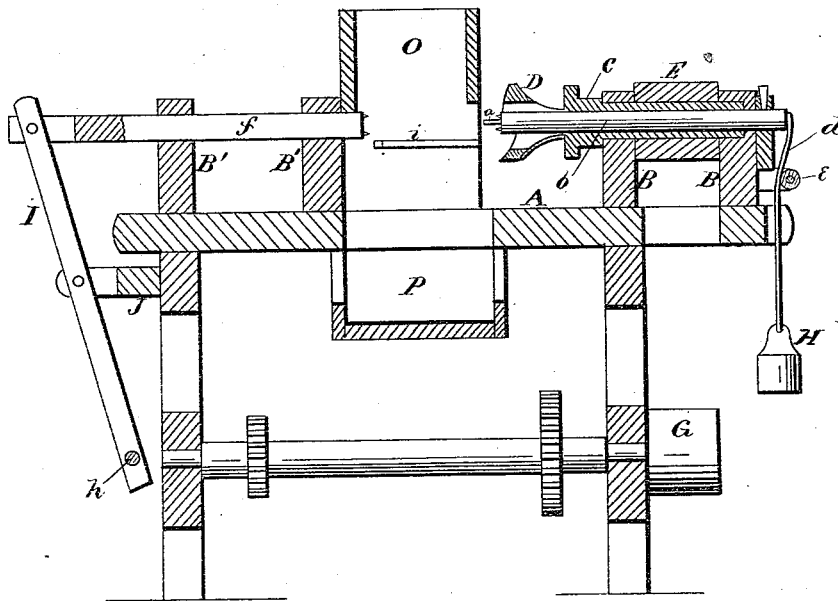

Inventor.

Felix Goulet.
Per H. S. Abbott.
Attorney.

Witnesses:

H. S. Duhamel
Thomas Byrne.

UNITED STATES PATENT OFFICE.

FELIX GOULET, OF ISLAND POND, VERMONT.

IMPROVEMENT IN GAGE-LATHES FOR TURNING WOOD.

Specification forming part of Letters Patent No. 162,229, dated April 20, 1875; application filed October 3, 1874.

To all whom it may concern:

Be it known that I, FELIX GOULET, of Island Pond, county of Essex and State of Vermont, have invented certain new and useful Improvements in Gage-Lathes for Turning Wood, of which the following is a specification:

The nature of my invention consists in the construction and arrangement of a machine for turning bobbins, as will be hereinafter more fully set forth.

In order to enable others skilled in the art to which my invention appertains to make and use the same, I will now proceed to describe its construction and operation, referring to the annexed drawing, which forms a part of this specification, and in which—

Figure 1 is a side elevation of my machine. Fig. 2 is a plan view of the same; and Fig. 3 is a longitudinal vertical section through the line *x x*, Fig. 2.

A represents the table of my machine supported upon a suitable frame-work. On the table A near one end are two bearings, B B, supporting a hollow shaft, C, upon the inner end of which is screwed or otherwise fastened a cutter-head, D. This cutter-head is constructed hollow, and provided with suitable knives or cutters *a a* formed to turn the bobbin to its proper shape, with a head at one end, as usual. On the hollow shaft C, between the bearings B B, is secured a pulley, E, to be connected, by a belt, with a pulley on the driving-shaft G below. Through the hollow shaft C is passed a center mandrel, *b*, to the outer end of which is attached a cord or strap, *d*, passing around a pulley, *e*, and provided with a weight, H, at its lower end. In bearings B' B' at the other end of the table A is placed a spur-mandrel, *f*, which is opposite to and on a line with the center mandrel *b*. The outer end of the mandrel *f* is slotted, and in the same is inserted the upper end of a lever, I, which is pivoted to an arm, J, extending from the frame supporting the table A. The lower end of the lever I is provided with a pin, *h*, which works in a cam, K, secured on the end of a shaft, L. This shaft runs parallel with the driving-shaft G, and receives its motion from the same by means of suitable gearing. On the table A at the inner side of the inner bearing B' is a vertical chute, O, of such

size as to receive within it the blocks from which the bobbins are to be made, which blocks are supported upon ledges *i i* on the inside of the chute, said ledges being immediately below the line of motion of the spur-mandrel *f*.

In the operation of the machine, when the spur-mandrel *f* is drawn outward by means of the cam K and lever I, the blocks fall down on the ledges *i*. As the cam revolves the spur-mandrel *f* is moved inward, and pushes before it the bottom block into the hollow cutter-head D and shaft C. The cutter-head revolving continually at the same time, the block is turned down by the cutters *a*, and as the turned part of the block is forced into the hollow head and shaft, it pushes back the center mandrel *b*, drawing up the weight H. When the inward stroke of the spur-mandrel *f* is completed the bobbin is completed, and as said mandrel recedes by the action of the cam and lever the weight H causes the center mandrel *b* to follow, forcing the completed bobbin back into the chute O, and when the backward stroke is completed the bobbin falls down through the space between the ledges *i i* through a slot in the table, and is carried off over an incline, P. The blocks in the chute at once settle down on the ledges *i i*, and the then bottom block is in like manner carried inward to the cutters by the next inward stroke of the spur-mandrel *f*.

Having thus fully described my invention, what I claim as new, and desire to secure by Letters Patent, is—

1. The combination of the hollow revolving shaft C, hollow cutter-head D, with cutters *a*, and the reciprocating center mandrel *b*, operated by the weighted cord *d*, substantially as and for the purposes set forth.

2. The combination of the hollow revolving shaft C, hollow cutter-head D, reciprocating center mandrel *b*, and reciprocating spur-mandrel *f*, substantially as and for the purposes herein set forth.

In testimony that I claim the foregoing as my invention I hereunto affix my signature this 26th day of September, 1874.

FELIX GOULET.

Witnesses:

JOSEPH W. PALMER,
Z. M. MANSUR.