

F. P. BOURNE.

Automatic Closing Attachment for Waste-Pipes.

No. 162,268.

Patented April 20, 1875.

Fig. 1

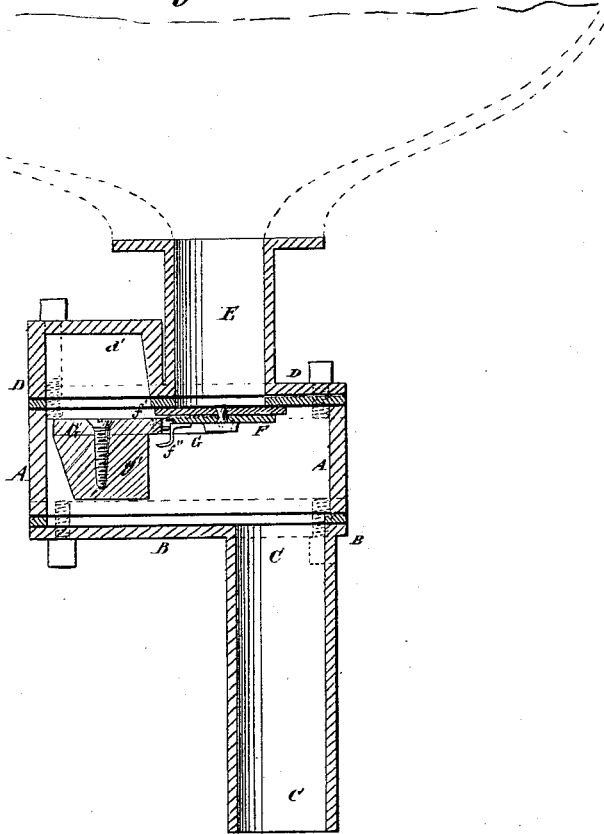
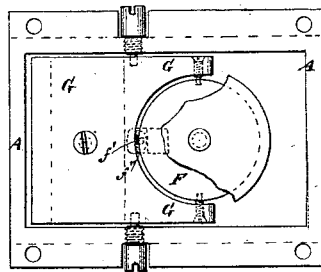

Fig. 2



WITNESSES:

A. W. Almqvist
J. H. Scarborough.

INVENTOR:

F. P. Bourne.

BY

Wm. M. Munn

ATTORNEYS.

UNITED STATES PATENT OFFICE.

F. PHILIP BOURNE, OF BROOKLYN, NEW YORK.

IMPROVEMENT IN AUTOMATIC CLOSING ATTACHMENTS FOR WASTE-PIPES.

Specification forming part of Letters Patent No. **162,268**, dated April 20, 1875; application filed March 6, 1875.

To all whom it may concern:

Be it known that I, F. PHILIP BOURNE, of Brooklyn, in the county of Kings and State of New York, have invented a new and useful Improvement in Automatic Closing Attachment for Waste-Pipes, of which the following is a specification:

Figure 1 is a vertical section of my improved attachment. Fig. 2 is a top view of the valve, valve-plate, and valve-chamber of the same, parts of the valve-packing being broken away.

Similar letters of reference indicate corresponding parts.

The object of this invention is to furnish an improved attachment for the waste-pipes of wash-bowls, bath-tubs, sinks, &c., which shall be so constructed as to prevent the escape of gases, odors, &c., from said waste-pipes, and which shall be simple in construction, inexpensive in manufacture, readily attached, and effective in operation.

The invention consists in the combination of the valve chamber or box, the bottom plate, the chambered top plate, the pipes, the pivoted valve, the pivoted valve-plate, and the weight with each other, to adapt the device to be applied to a waste-pipe, as hereinafter fully described.

A is the valve-chamber, to the bottom of which is bolted a plate, B, packing being interposed to make the joint tight. To the bottom plate B, close to one end, is attached, or upon it is formed, a pipe, C. To the top of the valve-chamber A is bolted a plate, D, to which, near one end, is attached, or upon it is formed, a pipe, E, the mouth of which is thus partly over the mouth of the pipe C. Packing is interposed between the plate D and the top of the box A, to make the joint tight, and which is extended so as to surround the mouth of the pipe E, and form a seat for the valve F. The valve F is a disk of circular or other form, which is faced with rubber, and is pivoted at its opposite edges to the recessed forward end of the valve-plate G, so that it may always fit squarely upon its seat, whether the plate G be exactly horizontal or not. The valve-plate G

is pivoted at its opposite edges to the upper part of the sides of the valve-box A. The valve F is kept from turning too much out of the plane of the plate G in one direction by a small stop, f^1 , attached to the valve-plate G', and which strikes against the concaved edge of the said valve, and in the other direction by the stop f^2 , attached to said valve, and which underlaps the concaved edge of said plate. The rear end of the plate G has a weight, g' , attached to it sufficient to hold the valve F firmly against its seat. In the rear part of the plate D, directly above the weight g' , is formed a recess or chamber, d' , into which the weight g' rises when the valve is opened.

This device is attached to the waste-pipe at a convenient distance below the wash-bowl, bath-tub, sink, or other receptacle, from which said waste-pipe leads.

With this construction, when the waste-water is admitted into the pipe E in sufficient quantity to overbalance the downward pressure of the weight g' , the valve F will be lowered into an inclined position, allowing the waste-water to flow into the pipe C. As soon as so much of the water has run out that the weight of that remaining will be overbalanced by the weight g' , the valve will close.

The valve will always have a small quantity of water above it, and will thus effectually prevent the escape of any gas or odor from the waste-pipe.

Having thus described my invention, I claim as new and desire to secure by Letters Patent—

The combination of the valve chamber or box A, the bottom plate B, the chambered top plate D d' , the pipes C E, the pivoted valve F, the pivoted valve-plate G, and the weight g' with each other, to adapt the device to be applied to a waste-pipe, substantially as here-in shown and described.

F. PHILIP BOURNE.

Witnesses:

EDGAR A. HUTCHINS,
GEORGE E. MAPES.