

E. W. MAXSON.
Washing-Machine.

No. 162,399.

Patented April 20, 1875.

Fig. 2

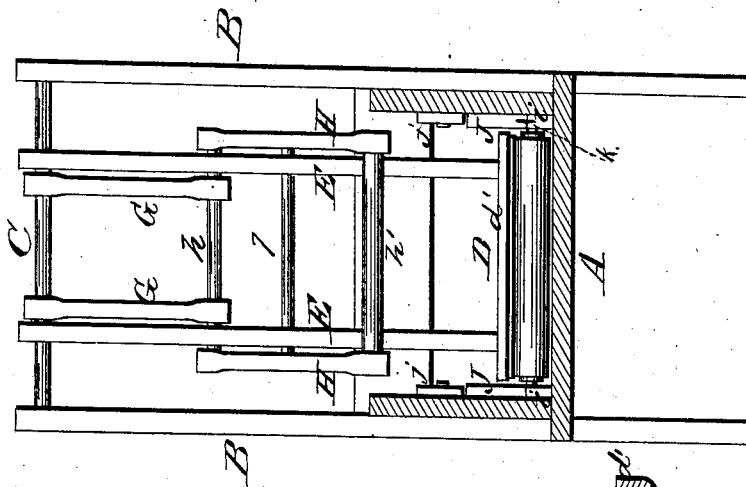

Fig. 3

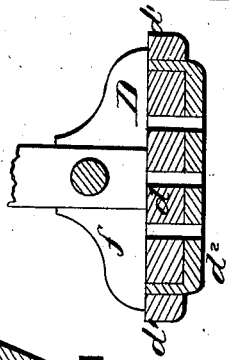
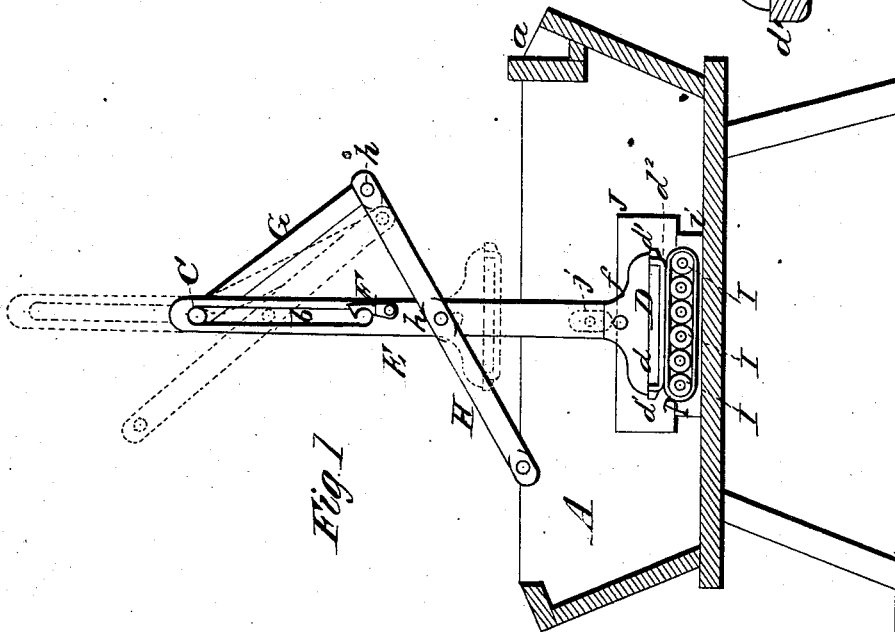

Fig. 1



WITNESSES
Robert Everett
Michael Carroll

INVENTOR
Erwin W. Maxson,
Chipman Fossum & Co
ATTORNEYS

UNITED STATES PATENT OFFICE.

ERWIN W. MAXSON, OF NICHOLSON, PENNSYLVANIA.

IMPROVEMENT IN WASHING-MACHINES.

Specification forming part of Letters Patent No. **162,399**, dated April 20, 1875; application filed October 24, 1874.

To all whom it may concern:

Be it known that I, ERWIN WILLIAMS MAXSON, of Nicholson, in the county of Wyoming and State of Pennsylvania, have invented a new and valuable Improvement in Washing-Machines; and I do hereby declare that the following is a full, clear, and exact description of the construction and operation of the same, reference being had to the annexed drawings, making a part of this specification, and to the letters and figures of reference marked thereon.

Figure 1 of the drawing is a representation of a longitudinal vertical section of my washing-machine. Fig. 2 is a transverse vertical sectional view of the same, and Fig. 3 is a detail view.

This invention has relation to washing-machines of that class wherein a vibrating rubber is employed in combination with a bed of rollers.

The nature of my invention consists in the employment of a vibrating rubber, which is composed of a rigid head, with perforated india-rubber or its equivalent, which is secured in place by means of strips, by removing which the worn-out covering can be replaced by a new one.

In the annexed drawings, A designates the wash-box, which is preferably made with vertical sides and inclined ends, and with a soap-receptacle, *a*, at one end, and which is mounted on legs. From the middle of the length of the box rise two standards, B B, which bear a horizontal oscillating shaft, C. D designates a rubber, to which are secured two arms, E E, having long slots *b*, through which passes the shaft C. The slots allow the rubber to be elevated, as indicated in dotted lines in Fig. 1, for the purpose of affording access to the fabrics in the box A.

When the rubber D is elevated it will be held in this position by means of a gravitating-hook, F, the beveled nose of which engages with the shaft C automatically, as will be observed from the accompanying drawings, when the rubber is raised to its highest point.

The rubber D consists of a rigid perforated portion, *d*, having parallel edges, and also a perforated covering, *d*², for the bottom of the portion *d*. Strips *d*¹ *d*¹ are used for holding the covering *d*² in place, and may be secured

by any convenient means. By removing these strips the covering can be taken off and a new one substituted. The covering may be made of india-rubber, or of any other suitable material, and it is perforated, as stated, for the purpose of allowing a free circulation of water through it. Cleats *f f* on the back of the rubber aid in preventing displacement of the strips *d*¹ *d*¹. G G designate two arms, which are rigidly secured to the shaft C between the arms E E. The free ends of these arms receive loosely through them a cross-bar, *h*, the ends of which are rigidly secured to the ends of two actuating-arms, H. These arms H are pivoted to the slotted arms E below the slots, and have applied to their opposite end a handle, *h*'.

Below the rubber is a bed of rollers, I, which have their end bearings in notched bed-pieces *i i*, which are rigidly secured to the bottom of the box A. Around these rollers passes an endless belt, P, which may be of cloth or any other suitable material. These rollers are retained in place by means of holding-down boards J J, which are pressed down upon the ends of the rollers by means of turn-buttons *j j*, secured to the sides of the box A.

By turning the buttons *j j* the boards J J will be released, and the rollers can be easily removed for the purpose of substituting a new belt. This belt P serves as a means for preventing the fabric which is being cleansed from accumulating in rolls above, or working down between the rollers I. The holding-down boards J J are prevented from endwise displacement by means of spurs *k*, attached to the lower edges of the said boards and extending into the bed-pieces *i i*.

I claim as my invention and desire to secure by Letters Patent—

The rubber D, consisting of the rigid perforated portion *d*, with parallel edges, the perforated covering *d*², the strips *d*¹, and cleats *f*, as and for the purpose set forth.

In testimony that I claim the above I have hereunto subscribed my name in the presence of two witnesses.

ERWIN WILLIAMS MAXSON.

Witnesses:

G. L. WEAVER,
E. BALL.