

G. CROWL.
Metallic Roofing.

No. 162,461.

Patented April 27, 1875.

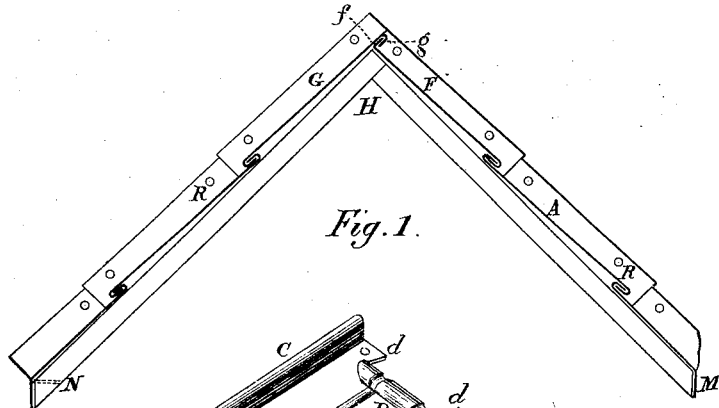
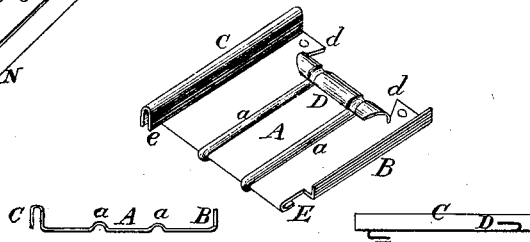

Fig. 1.



Figs. 3.

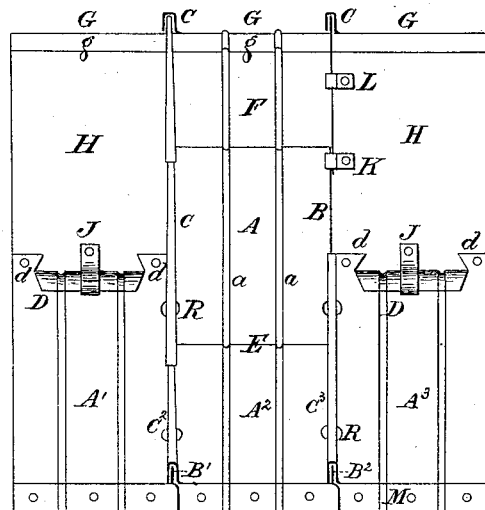
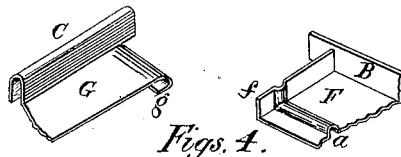

Fig. 2.



Figs. 4.

Ruth K. Abbott
Andrew Choffin } Witnesses.

George Crowl, Inventor.
by Job Abbott, Attorney.

UNITED STATES PATENT OFFICE.

GEORGE CROWL, OF NEW LISBON, OHIO.

IMPROVEMENT IN METALLIC ROOFING.

Specification forming part of Letters Patent No. **162,461**, dated April 27, 1875; application filed March 23, 1875.

To all whom it may concern :

Be it known that I, GEORGE CROWL, of New Lisbon, in the county of Columbiana and State of Ohio, have invented certain new and useful Improvements in Metallic Roofing; and that the following is a full, clear, and exact specification thereof, which will enable others skilled in the art to make and use the said invention.

My invention relates to the construction of a metal roof-plate, having one or more light corrugations formed in it lengthwise, and at intervals in its width, the object being to remove the "buckle" ordinarily existing, and to stiffen the plate and cause it to lie flat on the roof without causing any considerable increase in the amount of metal, or any difficulty in forming the end hooks for uniting the plates.

Said invention also relates to an improved manner of forming and attaching the upper ends of the roof-plates, and to an improved manner of uniting the plates at the roof-ridge, as is hereinafter more fully shown.

In the accompanying drawing, Figure 1 is a cross-section of roof embodying my invention. Fig. 2 is a top or plan view. Figs. 3 are detailed views of a roof-plate. Figs. 4 are detailed views of the roof-plates at the roof-ridge.

The roof-plate A is made of sheet metal, and has one or more light corrugations, *a*, formed in it, by passing the flat plate between suitably-formed rollers. Two of these corrugations are usually sufficient for the plates, and they are formed at some distance from each other, and are of slight height, being designed simply to remove the buckle and stiffen the plate, without making it impracticable to bend end hooks on the plate, as is the case with ordinary corrugated iron.

The lip B is bent up on one side of the plate A, and the hook C is formed on the other side, as shown in Figs. 3.

The hook D is cut from the upper end of the plate and bent upward, leaving the ears *d d* at each side; and the hook E is cut from the lower end of the plate and bent downward, leaving the lip B and hook C extending down below the hook E, as shown in Figs. 3.

The upper roof-plate F has a lip, *f*, cut in it, and bent up between the edge lip and hook B C into line with the opposite side of the

roof, and a hook, *g*, is cut in and bent down on the opposite roof-plate G, as shown in Figs. 4.

In putting on the roof, the plate A¹ is placed at the bottom and at one side of the roof, its lower end being secured by nails, as shown at M, or simply by hooking over the lower edge of the roof, as indicated by dotted lines at N, Fig. 1, and its upper end being secured by nails through the ears *d d*, and also by hitches J, with hook into the hook D, and are nailed to the roof H, as shown in Fig. 1.

The next plate, A², which is arranged to break joints with the plate A¹, is then placed on the roof, with its hook C² over the lip B¹ of the plate A¹, and is secured by nails and hitch in the same manner as the plate A¹; and the next plate, A³, and so on, are applied in a similar manner.

The plate A of the next tier above has its hooks E hooked into hooks *d*² of the plate A², and its hooks *c* fit over the hooks C² of the plate A² and the upper part of the lip B¹ of the plate A¹, while its lip B fits under the hook C³ of the plate A³.

The upper end of this plate is secured to the roof in the same manner as the plates A¹ A², and its sides, as well as those of the other plates, are secured to the roof by hitches K L, which hook onto the lip B, and are nailed to the roof, the several plates being further united to each other by rivets R, through the vertical ribs formed by the hooks C and lips B.

The upper plate F is secured to the roof in the same manner as the other plates, and the hook *g* of the opposite plate G is hooked over the lip *f*, as shown in Fig. 1; while the hooks C of the plates G fit over the ends of the hooks and lips of the plate F, thus closing over the ridge and completing the whole roof without leaving any exposed nails by which the plates are secured to the roof.

What I claim herein as my invention, and desire to secure by Letters Patent, is—

1. A metallic roof-plate, A, having corrugations *a*, formed therein at intervals from each other, and at such slight height as not to prevent the bending of hooks at the ends of said plates, after the corrugations have been formed therein, as is herein specified.

2. A metallic roof-plate having light corru-

gations *a a* formed therein at intervals from each other; a hook, D, turned at its upper end, with ears *d d* left at its sides; lip B and hook C, turned at its sides; and a hook, E, turned at its lower end, between said lip and hook, substantially as and for the purpose specified.

3. A metallic roof combining the following features of construction, to wit: light corrugations at intervals in the plates; vertical plate-seams formed by uniting the lip and hook of adjacent plates; flat cross-seams formed by central upper hook of a plate, and a transverse

lower hook of the next plate above; and a ridge-joint formed by hooking together the ridge-plates in the plane of one side of the roof; the several parts being constructed, arranged, and secured on the roof, substantially as and for the purpose specified.

As evidence of the foregoing, witness my hand this 6th day of March, A. D. 1875.

GEORGE CROWL.

Witness:

HENRY E. FROST,
E. L. RANDOLPH.