

J. H. FLYNT.

Construction of Watch Movement.

No. 162,542.

Patented April 27, 1875.

Fig: 1.

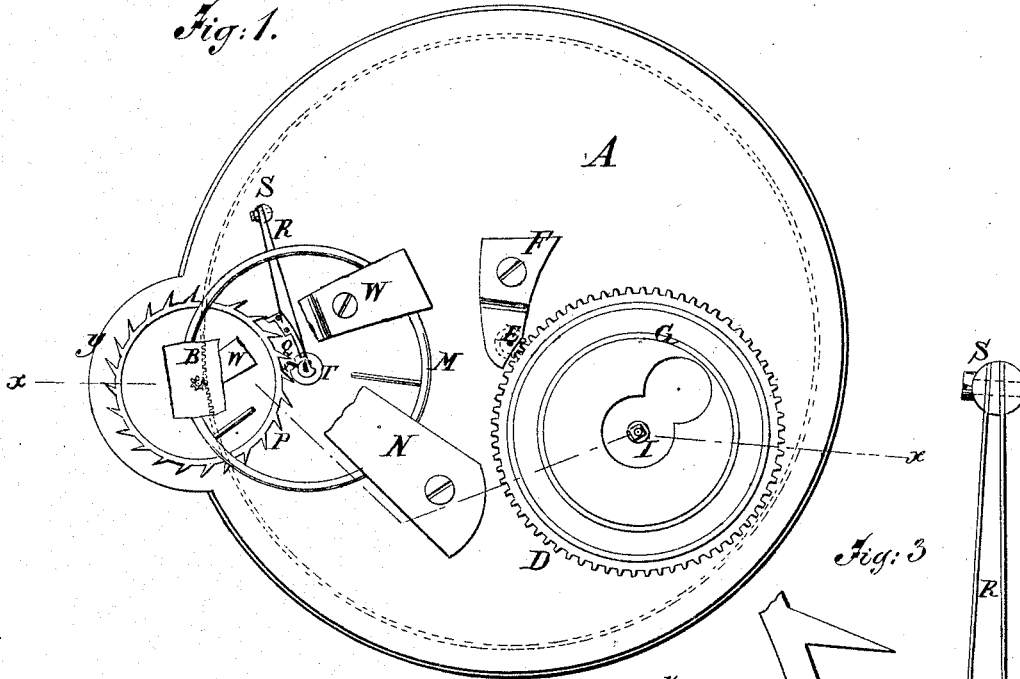

Fig: 3

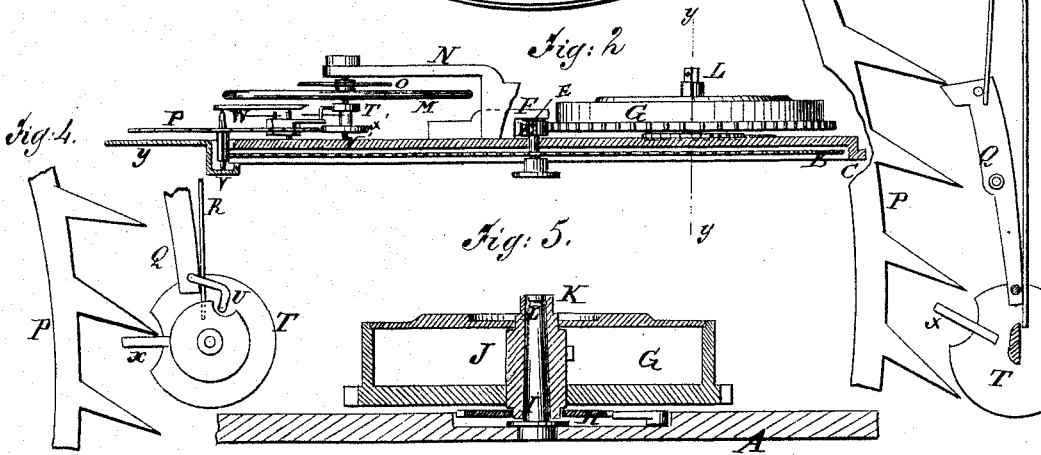
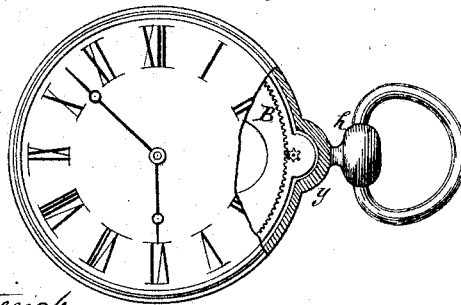

Fig: 6



WITNESSES:

Cas. Nida
Gustave Dieleuch

INVENTOR:

J. H. Flynt

BY

Munnell
 ATTORNEYS.

J. H. FLYNT.

Construction of Watch Movement.

No. 162,542.

Patented April 27, 1875.

Fig 7.

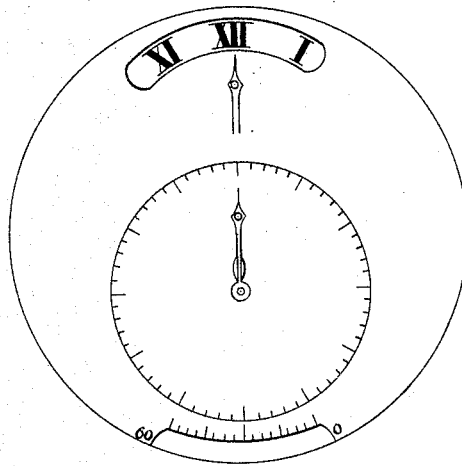
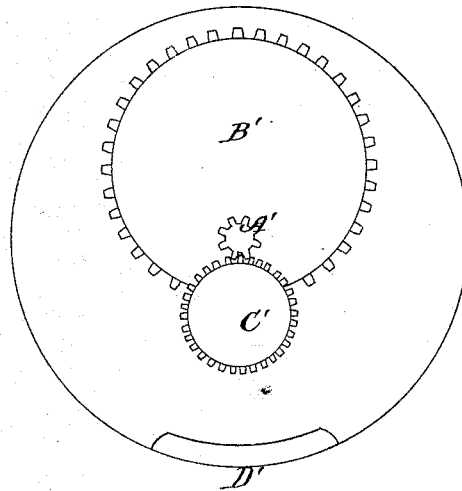

Fig 8.



WITNESSES:

Chas. A. Pettit
John Kemont

INVENTOR:

J. H. Flynt
BY *Wm. S. B.*

ATTORNEYS.

UNITED STATES PATENT OFFICE.

JAMES H. FLYNT, OF DULUTH, MINNESOTA.

IMPROVEMENT IN THE CONSTRUCTION OF WATCH-MOVEMENTS.

Specification forming part of Letters Patent No. **162,542**, dated April 27, 1875; application filed July 11, 1874.

To all whom it may concern:

Be it known that I, JAMES H. FLYNT, of Duluth, in the county of St. Louis and State of Minnesota, have invented a new and useful Improvement in the Construction of Watch-Movements, of which the following is a specification:

The invention will first be fully described, and then pointed out in the claim.

In the accompanying drawing, Figure 1 is a plan view of the watch-movement, showing the mainspring-barrel and barrel-wheel, the balance-wheel and escapement, and the large cog-wheel, (mainly in dotted lines,) which takes the place of three wheels of the common watch-movement. Fig. 2 is a cross-section of Fig. 1, taken on the line *x x*. Fig. 3 is an enlarged view of the escapement detached. Fig. 4 shows a detail of the escapement-movement. Fig. 5 is a section taken on the line *y y* of Fig. 2, showing a detail of the mainspring, barrel, ratchet-wheel, and winding-post. Fig. 6 is a face view of the watch complete, (partly in section,) to show the rim of the large plate-wheel and the escapement-pinion. Fig. 7 is a face view of the dial-plate. Fig. 8 is a view of the under side of dial-wheel, of the minute-wheel, and the cannon-pinion.

Similar letters of reference indicate corresponding parts.

A is a large pillar-plate of nearly the diameter of the watch. This plate is made of thick brass or other suitable metal, to which the entire movement is attached. B is a large cog-wheel, placed in a cavity formed by the surrounding fillet C of the pillar-plate A, and directly beneath the face of the watch. This wheel is revolved by the barrel-wheel D, which engages with the pinion E of the center-post. This post carries the hands of the watch, and is fast in the center of the large wheel B. F is the bridge of this center-post. G is the barrel of the mainspring. H is the ratchet on the stud I.

I rivet the stud I to the pillar-plate, and drill out the winding-arbor J to fit onto it, and square it for the ratchet. The arbor is held in place by the pin K, which passes through

the side of the key-square L, a groove being turned in the end of the stud, as seen in the drawing. By this improvement in the barrel-post I am enabled to dispense with a barrel-bridge and a number of screws.

M is the balance-wheel. N is the balance-wheel bridge. O designates the hair-spring. P is the escapement-wheel. Q is the detent-lever. R is the detent-lever spring, which is made fast to the stationary post S. This spring is made of a common hair-spring, in two parts, one part bearing upon the pin in the end of the lever, and the other acting upon the table-roller T and the other end of the lever.

U is the lifting pallet and balance-staff on the end of the detent-levers, which engages with the table-roller, as seen in Fig. 4. X is the impulse-pallet. V is the escapement-arbor, and W is the escapement-bridge. V' is the balance-wheel arbor. X' is the verge. This is essentially the "chronometer-escapement;" but it is so much simplified as to be hardly recognized, while performing all its functions. The parts are much lighter, and more easily repaired or replaced.

Y is a projection of the base of the stem Z, to accommodate the escapement-wheel, as by this arrangement that wheel is made to project from the circle, but adding to (rather than detracting from) the general appearance of the watch.

By this construction of the watch-movement the wheels are much reduced in number, and the parts so much simplified generally that a watch upon this plan can be produced at much less expense than it can when made in the usual manner. The friction is also so much reduced that the movement requires but about half the usual spring-power employed in ordinary watches.

In Fig. 8, A' represents the cannon-pinion, which fits into a hole in the center-pinion of the large wheel. B' is the dial; C', the minute-wheel, and D' an opening in plate to show seconds on large wheel.

The dial-plate is intended to shut snugly over the pillar-plate, while the pivot of the small dial-wheel fits tightly the hole in the

center pinion, and the center-wheel pivot receives the small dial-wheel pivot.

Having thus described my invention, I claim as new and desire to secure by Letters Patent—

A watch - movement in which motion is communicated from the mainspring - barrel to the escapement - wheel through a single

pinion and wheel, said wheel being of nearly the circumference of the pillar-plate, and arranged between the face and the pillar-plate.

JAMES H. FLYNT.

Witnesses:

S. HOFFMAN, Jr.,

WILLIAM A. GULICK.