

E. FOSTER.
 Carbureting Gas-Machine.

No. 162,543.

Patented April 27, 1875.

Fig. 1

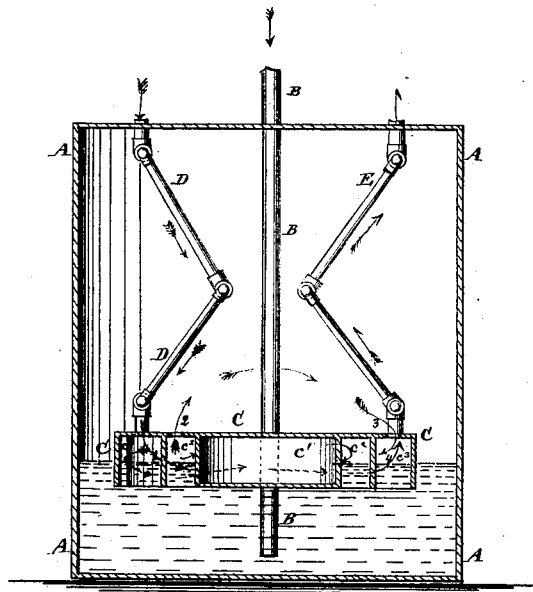

Fig. 2

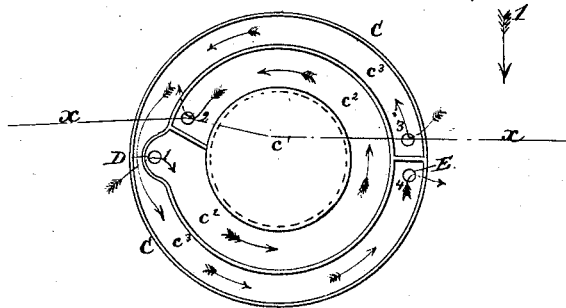
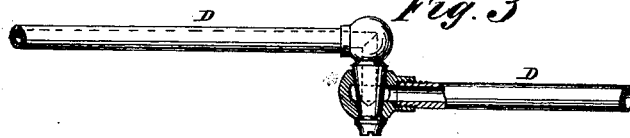

Fig. 3



WITNESSES:
A. W. Almqvist
A. J. Terry

INVENTOR:
Elon Foster
 BY: *[Signature]*
 ATTORNEYS.

UNITED STATES PATENT OFFICE.

ELON FOSTER, OF NEW YORK, N. Y.

IMPROVEMENT IN CARBURETING GAS-MACHINES.

Specification forming part of Letters Patent No. **162,543**, dated April 27, 1875; application filed February 5, 1875.

To all whom it may concern:

Be it known that I, ELON FOSTER, of the city, county, and State of New York, have invented a new and useful Improvement in Carbureting Gas-Machines, of which the following is a specification:

Figure 1 is a vertical longitudinal section of my improved machine, taken through the line *x x*, and looking in the direction indicated by arrow 1. Fig. 2 is an under-side view of the float. Fig. 3 is a detail view of a part of one of the jointed pipes, part being broken away to show the construction.

Similar letters of reference indicate corresponding parts.

My invention has for its object to furnish an improved gas-machine for carbureting air or gas, and which shall be so constructed that it will operate equally well whether a large or a small quantity of the hydrocarbon be in the tank, and which shall at the same time be simple in construction and reliable in operation.

The invention will first be fully described, and then pointed out in the claim.

A represents a tank of any desired capacity, and which, for convenience, I prefer to make cylindrical in form. The naphtha or other hydrocarbon is introduced in the tank A through the pipe B, which passes in through the top of said tank, and passes down along one side nearly to its bottom, as shown in Fig. 1, so that its lower end may always be covered with the hydrocarbon, to prevent the escape of any gas through the said pipe. Within the tank A is placed a float, C, in the middle part of which is formed an air-chamber, *c*¹, of such a size as to give the requisite buoyancy to the float. The float C is connected with the top of the tank A by one, two, or more pipes—the one, D, when two are used, being designed for the admission of the air or gas to be carbureted, and the other, E, for the egress of the carbureted gas. The pipes D E have three or more joints formed

in them to allow them to fold together, to allow the float C to move up and down freely, according to the amount of hydrocarbon in the tank A. The joints of the pipes D E may be similar to the joints of gas-brackets, or of any other construction that will allow the said pipes to fold and unfold without closing the passage through the said pipes. Upon the lower side of the float C, around the air-chamber *c*¹, are formed two ring-passages, *c*² *c*³, each of which is made with a single cross-partition. The passages *c*² *c*³ are open downward, so that the air or gas passing through them may come in contact with the hydrocarbon, upon which the float C rests. With this construction, as the air or gas enters through the pipe D, it enters the passage *c*² through the hole 1, passes through the said passage *c*², and escapes through the hole 2, into the upper part of the tank A. As the pressure increases in the upper part of the tank A, the gas passes down through the hole 3, into the passage *c*³, passes through said passage, and escapes through the hole 4, into the outlet-pipe E. By this arrangement the air or gas is brought into contact with the hydrocarbon twice before it escapes through the outlet-pipe E.

Having thus described my invention, I claim as new and desire to secure by Letters Patent—

The combination, with tank A and two pipes, D E, jointed as described, of the float C, having holes 1 2 3 4, air-chamber *c*¹, and bottom open passages *c*² *c*³, all constructed and arranged substantially as set forth, whereby the air is entered through pipe D, passes through hole 1 into passage *c*², thence through hole 2 into upper part of tank, thence through hole 3 into passage *c*³, and thence through hole 4 into a jointed discharge-pipe, E.

ELON FOSTER.

Witnesses:

JAMES T. GRAHAM,
T. B. MOSHER.