

M. JINCKS.

Churn.

Patented April 27, 1875.

No. 162,560.

Fig. 1.

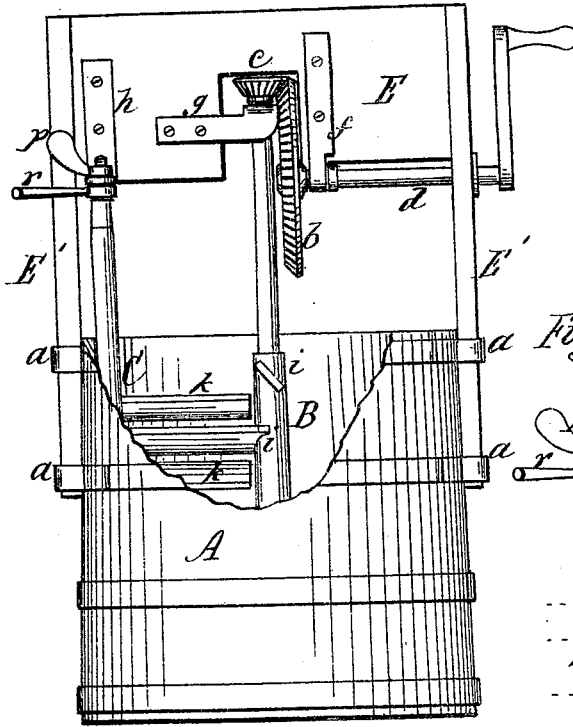

Fig. 3.

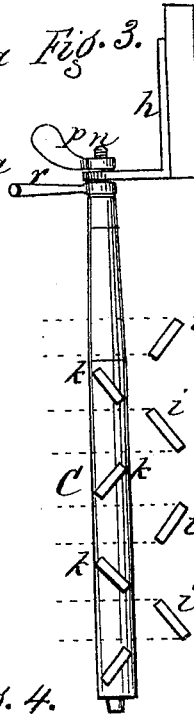

Fig. 2.

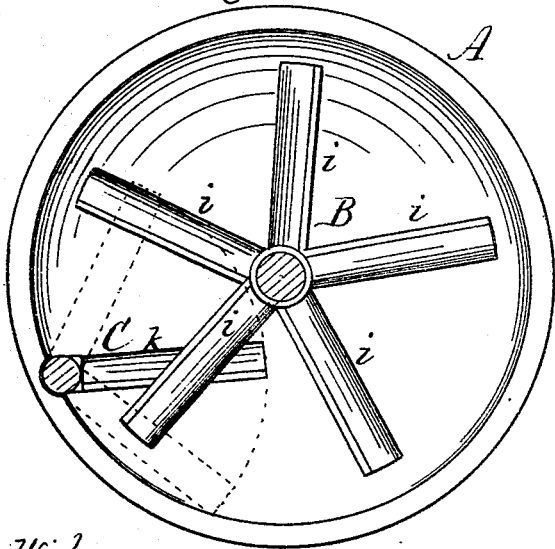
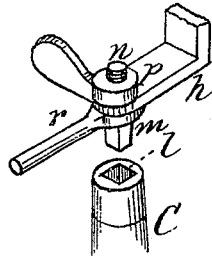

Fig. 4.



Witnesses.  
 Edwin. B. Scott.  
 Jacob Spahr

Inventor.  
 Melvin Jincks,  
 by R. F. Osgood,  
 atty.

# UNITED STATES PATENT OFFICE.

MELVIN JINCKS, OF WALLACE, ASSIGNOR OF ONE-HALF HIS RIGHT TO  
FRANCIS M. CONLEY, OF COHOCTON, NEW YORK.

## IMPROVEMENT IN CHURNS.

Specification forming part of Letters Patent No. 162,560, dated April 27, 1875; application filed  
September 21, 1874.

*To all whom it may concern:*

Be it known that I, MELVIN JINCKS, of Wallace, in the county of Steuben and State of New York, have invented a certain new and useful Improvement in Churns; and I do hereby declare that the following is a full, clear, and exact description of the construction and operation of the same, reference being had to the accompanying drawings, in which—

Figure 1 is an elevation. Fig. 2 is a plan of the churn, with the dasher-rods in cross-section. Fig. 3 is a diagram, showing the operation of the dasher and breaker wings. Fig. 4 is a perspective view of the adjusting and tightening devices connected with the breaker.

This improvement belongs to that class of upright rotary churns in which a breaker is used, in connection with the dasher, for breaking and agitating the cream. Heretofore, so far as I am aware, such breakers have been made fixed and stationary, and therefore the cream has had a uniform and unvarying motion.

My invention consists, essentially, in combining with the dasher a breaker which is adjustable on its axis to different positions, so as to give different actions, according to the different conditions of the cream, said breaker being situated on one side of the churn. It also consists in the combination, with the breaker-shaft, of a tenon-bearing which fits in a socket of the shaft, and a handle and nut for turning the shaft and tightening it in place, all as hereinafter described.

In the drawings, A indicates the churn-body, which may be of cylindrical or other form. B is the dasher, and C is the breaker. E is a frame, provided with two arms, E' E', which are inserted in staples a a, or equivalent attachments to the churn-body, by which means the frame is attached or removed at pleasure. This frame carries the gear-wheel b and pinion c, by which the churn is driven, the gear-wheel resting on a shaft, d, driven either by a crank or a pulley. The wheel and pinion rest in strap-bearings f g, by which they are held in position. A strap-bearing, h, is also connected with the frame to retain the tenon-bearing, which connects with the break-

er-shaft, as will presently be described. The dasher rests in the center of the churn, and the breaker on one side, as shown in Figs. 1 and 2. They are respectively provided with a set of wings, i i i and k k k, those of the dasher intermatching with or passing between those of the breaker. The wings of each set are inclined alternately in opposite directions, and those of one set stand in the opposite direction from those of the other set, as shown in the diagram, Fig. 3. By this means counter-currents are produced, which equalize and oppose each other, thereby producing a great agitation, and effectually breaking the globules of the cream. The wings of the breaker project radially in a vertical line; but those of the dasher are arranged spirally around the axis, so that they pass the breaker in rotation, one after another, thereby producing a series of currents at different depths in the cream. The upper ends of the dasher and breaker shafts are provided with square sockets l l, in which fit corresponding tenon-bearings, connected with the frame E. By this means the frame can be lifted off, leaving the shafts standing in the churn. The tenon-bearing m, connecting with the breaker-shaft, is connected with the strap h, by which it is supported. It has on top a thread, n, on which screws a nut, p, and it has beneath a handle, r, provided with a square socket, which fits on the tenon portion, and rests between the bearing h and the top of the breaker-shaft. By loosening the nut and turning the handle the breaker can be turned to any position, and tightened again by tightening the nut.

I am aware that rotary churns with fixed breakers of different forms are well known. The novelty in my case consists in locating the breaker-shaft on one side of the churn, and making it adjustable to different positions on its own axis, as shown by the black and dotted lines in Fig. 2. The breaker can be set so as to create more or less agitation, as the temperature or condition of the cream may require. When set as indicated by the whole lines, the cream, as it is thrown outward by the centrifugal action, breaks bodily against it. When in the position indicated by the dotted lines at the top, it is thrown behind the

wings and breaks against the shaft. When set as at the bottom, it creates the least agitation, and allows gathering of the butter. The breaker is more effective on one side, as the cream is heaped at the sides of the churn by the centrifugal action, and when turned one side it leaves the body of gathered butter free and undisturbed.

What I claim, and desire to secure by Letters Patent, is—

1. The combination, with the revolving dasher B, of the breaker C, located on one side of the churn, and adjustable to different positions

on its axis, as shown and described, and for the purpose specified.

2. The combination, with the breaker C, of the tenon-bearing *m*, thumb-nut *p*, and handle *r*, as and for the purpose specified.

In witness whereof I have hereunto signed my name in the presence of two subscribing witnesses.

MELVIN JINCKS.

Witnesses:

WM. SLATTERY,  
M. A. PECK.