

D. S. JONES.
Rotary-Engine.

No. 162,561.

Patented April 27, 1875.

Fig 1.

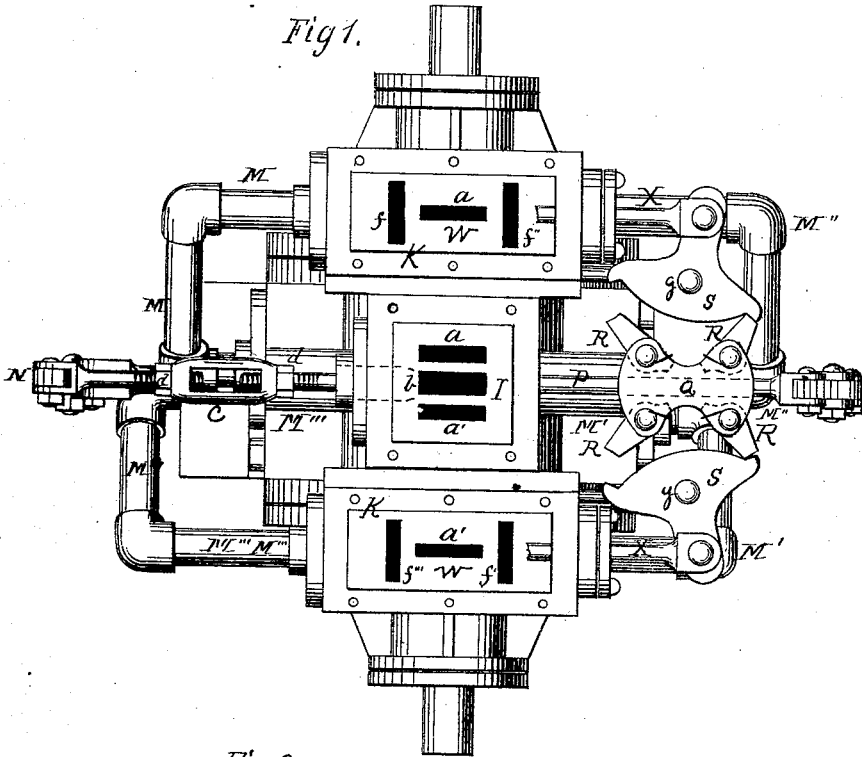
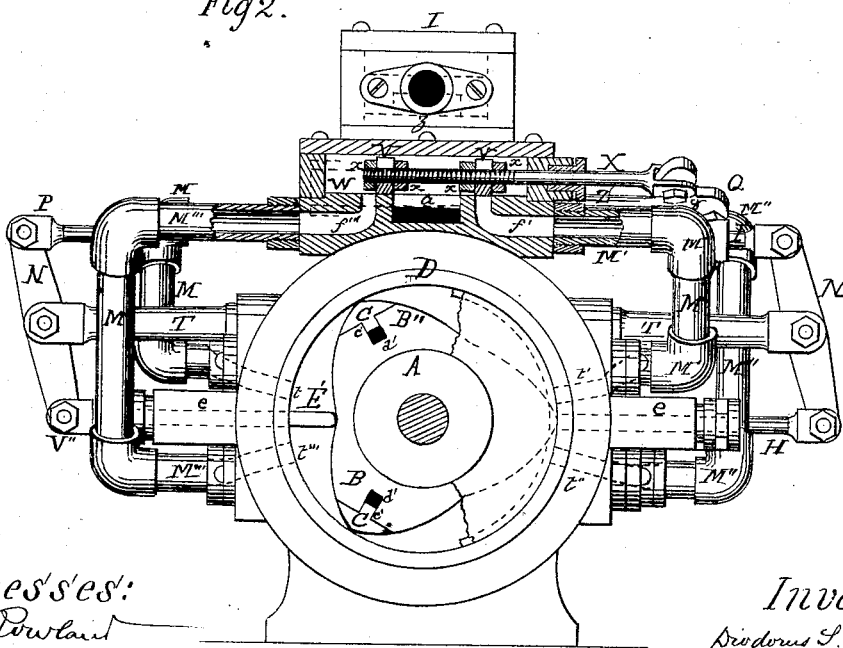

Fig 2.



Witness'es:
C. Rowland
Fred. R. Gooddys

Inventor:
Dionides S. Jones
by his Attys
Cox & Cox

D. S. JONES.
Rotary-Engine.

No. 162,561.

Patented April 27, 1875.

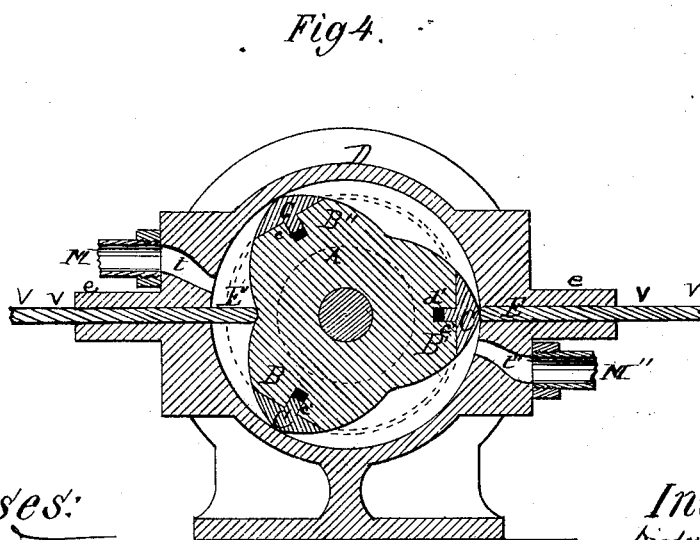
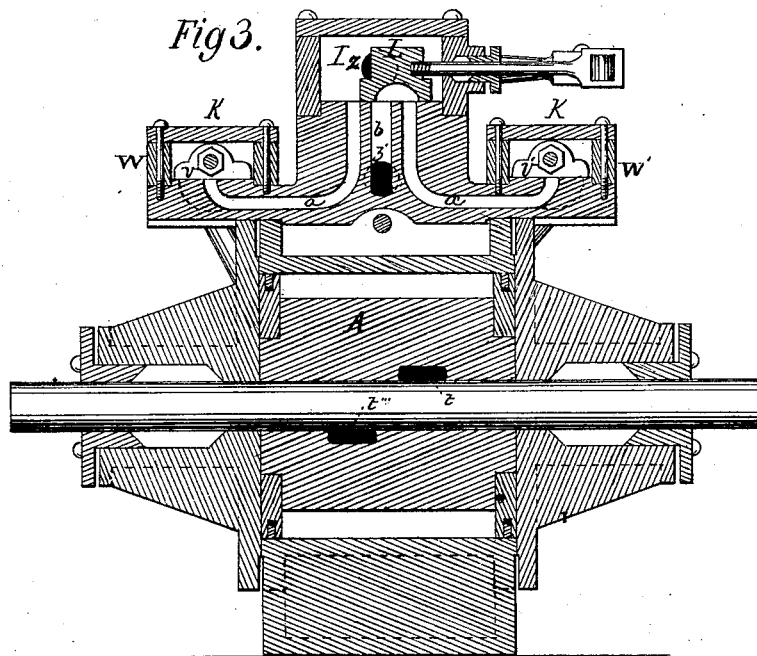

Witnesses:
C Rowland
Fred. R Goodridge

Inventor:
Diodorus S. Jones
by his Atty
Chas. Y Cox

UNITED STATES PATENT OFFICE.

DIODORUS S. JONES, OF SHAMOKIN, PENNSYLVANIA, ASSIGNOR OF ONE-HALF HIS RIGHT TO WILLIAM H. DOUTY, OF SAME PLACE.

IMPROVEMENT IN ROTARY ENGINES.

Specification forming part of Letters Patent No. **162,561**, dated April 27, 1875; application filed March 19, 1875.

To all whom it may concern:

Be it known that I, DIODORUS S. JONES, of Shamokin, Northumberland county, Pennsylvania, have invented certain new and useful Improvements in Steam-Engines, of which the following is a specification:

The invention relates to that class of machines known as rotary engines, and is constructed and operated in the manner hereinafter fully set forth.

Figure 1 is a top view of a device embodying the elements of the invention, having the chest-covers taken off. Fig. 2 is a side view, partly in section and part broken out. Fig. 3 is a longitudinal vertical central section. Fig. 4 is a transverse view, showing the internal parts of the engine.

In the accompanying drawings, A is a piston, constructed with the three abutments B B' B'', the apexes of which are formed by the metal packing-pieces C, consisting of an elongated conical strip, curved transversely, as shown, on its outer surface, and at the longitudinal center of its under surface supplied with the tongue *c'*, which enters the recess *d'*, the lower edge of the tongue being supplied with a spring (not shown) to give the pieces C a proper outward pressure, causing its apex to impinge the inner surface of the cylinder D. The cylinder D is supplied with steam through the ports *t t' t'' t'''*, placed above and below the slides E E', as shown in dotted lines at Fig. 2, and communicating, respectively, with the pipes M, M', M'', and M''', which lead upward, as shown, M and M''' entering at each end of the auxiliary steam-chest W through the ports *f' f''*, and the pipes M and M'' into the chest W through the ports *f f''*, as shown, the steam-chests being connected by the conduits *a a'* with the principal chest I, having at its center the port *b*, leading to the exhaust Z'. The center or principal chest I is provided with a valve, L, operable by the means shown, and controlling the ports *a, a', and b*. The auxiliary chests W W' are supplied with the cut-off slide-valves *v v'*, controlling the ports *f f' f'' f'''*, the valves being connected at each end with

the piston X, which projects through the chest, and is connected with the shank of the tappets S, which are pivoted at their centers to the standard *i*, and operate upon the plate Q, which has pivoted at each corner the teeth R, having a spring that gives them a tension toward the extremities of the tappets S, so that, as the tappets are oscillated, the plate is moved alternately. The plate Q is provided at its horizontal center with the rod P, which extends across the device, its opposite end being connected with the upper end of a walking-beam, N, pivoted upon the standard T, and pivoted at its lower end to the extremity of the piston-rods V'', which pass through the chamber *e*, and are connected, their inner ends forming the slides E E', which are placed opposite each other, and respectively between the ports *t t'''* and *t' t''*, their edges impinging upon the piston A, and working in the chambers *e* and *b*, operating the rods V''.

Steam being admitted to the principal chest I, the throttle-valve is operated, opening, for example, the port *a*, whence the steam passes into the auxiliary chest W, whence it passes through the port *f* into the pipe M, thence through the port *t* into the cylinder D, the devices wherein being for illustration, as shown at Fig. 4. The steam admitted through the port *t* acts upon the slide E', and forces the piston to rotate from the slide. This continues until the slide E' is forced back by the packing on the abutment B coming in contact therewith. This operates the piston-rod V'', actuating the rod P, which causes the slide E to be forced inward, and thus present a backing to assist the operation of the piston. The rotation of the piston D continues until the port *t* is closed and the port *t'* opened, which permits the escape of the steam through the pipe M' into the port *f'*, which being opened by the operation of the slide E actuating the rods V and P, and through them the plate Q and tappets S, the steam passes into the auxiliary chest W', exhausting through the port *a'* and escape *b*.

To reverse the engine it is only necessary to move the throttle-valve in a contrary direc-

tion to that aforesaid, which causes the steam to act and exhaust through the opposite set of pipes and ports.

What I claim as my invention, and desire to secure by Letters Patent, is—

1. The combination of the piston A, slides E E', and their connections, with the rod P, plate Q, tappets S, and teeth R and rods X, substantially as set forth.

2. The auxiliary steam-chests W W', provided with the cut-off valves V V' and ports

f f' f'' f''', in combination with the rods X, tappets S, teeth R, and rod P, substantially as shown and described.

In testimony that I claim the foregoing improvement in steam-engines, as above described, I have hereunto set my hand and seal this 5th day of February, 1875.

DIODORUS S. JONES. [L. s.]

Witnesses:

JOSEPH WILDMAN,
GEO. MARSHALL.