

L. M. HILLS & E. ALLEN.
Wood-Planing Machine.

No. 162,649.

Patented April 27, 1875.

fig 5

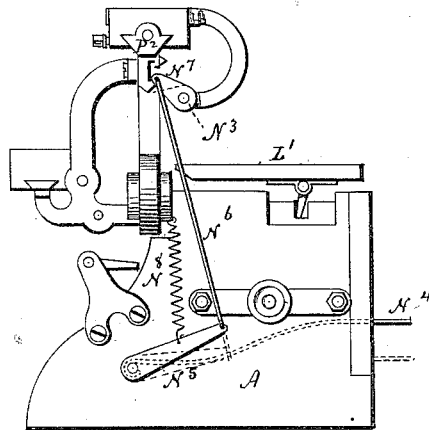

fig 4

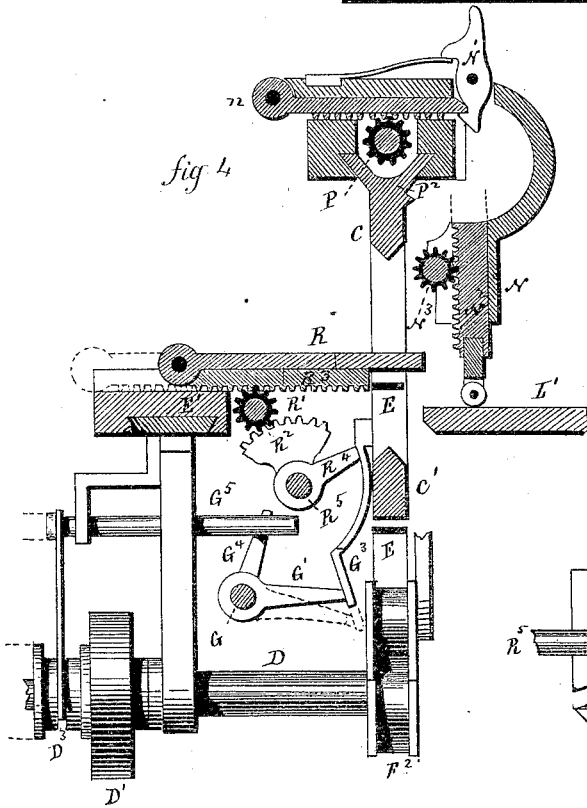

fig 6

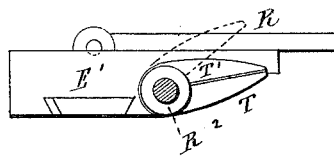
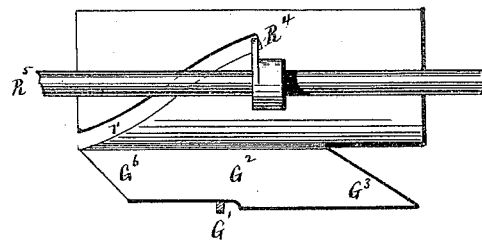

fig 7



Witnesses.

A. J. Tibbits
G. S. Humway

Lewis M. Hills & Edwin Allen
Inventor

By Atty.

John P. Earl

UNITED STATES PATENT OFFICE.

LEWIS M. HILLS, OF NEW HAVEN, AND EDWIN ALLEN, OF NORWICH,
CONNECTICUT; SAID ALLEN ASSIGNOR TO SAID HILLS.

IMPROVEMENT IN WOOD-PLANING MACHINES.

Specification forming part of Letters Patent No. 162,649, dated April 27, 1875; application filed August 28, 1874.

To all whom it may concern:

Be it known that we, LEWIS M. HILLS, of New Haven, in the county of New Haven and State of Connecticut, and EDWIN ALLEN, of Norwich, in the county of New London and State of Connecticut, have invented new Improvements in Wood-Planing Machines; and we do hereby declare the following, when taken in connection with the accompanying drawings and the letters of reference marked thereon, to be a full, clear, and exact description of the same, and which said drawings constitute part of this specification, and represent, in—

Figure 1, a front-side view; Fig. 2, an end view; Fig. 3, a rear view; Fig. 4, a transverse section, enlarged; and Figs. 5, 6, and 7, detached views.

This invention relates to an improvement in machines for working wood, specially designed for jointing, molding, and for like purposes; and it consists in the combination of mechanism, as more fully hereinafter described.

A is the frame of the machine; B, the carriage, arranged between longitudinal guides C C'. To this carriage a longitudinal reciprocating movement is imparted from a driving-shaft, D, in the following manner: A band, E, is attached to one end of the carriage B, passes to the end of the machine over a fixed pulley, F, thence around a pulley, F¹, then around a pulley, F², on the driving-shaft D, thence around another pulley, F³, thence around a fixed pulley, F⁴, at the opposite end of the machine, and that end E' of the band attached to the opposite end of the carriage B. The pulleys F¹ F³ serve as tighteners or carrying-pulleys. As the shaft D is turned in one direction it will draw the carriage B toward one end of the machine, and the reverse revolution of the shaft D will draw the carriage B in the opposite direction; hence, by changing the direction of revolution of the driving-shaft D, a reciprocating movement is imparted to the carriage B. On the driving-shaft D are two pulleys, D¹ D², each having their independent bands arranged to cause the pulleys to revolve in opposite directions. Between these is a clutch, D³, which revolves with the shaft, and which, when moved in connection with either of the pulleys D¹ D², will cause the shaft to

revolve with such pulley in substantially the usual manner for imparting reverse motion to the revolving shaft. That this reversal may be automatic and adjustable, so that the distance which the carriage B moves may be varied, a longitudinal shaft, G, is arranged, and from this an arm, G¹, extends toward an extension, G², of the carriage. (See Figs. 4 and 7, enlarged.) This extension has an incline, G³, at one end, which, as it approaches the arm G¹, will engage that arm and cause it to ride up the incline, as denoted in broken lines, Fig. 4. From the shaft G another arm, G⁴, extends into connection with a slide, G⁵, and this slide is in connection with the clutch D³, so that when the arm G¹ rises it will turn the shaft G, and thereby throw the clutch into connection with the outside pulley D². This will cause the return of the carriage, and, in returning, an incline, G⁶, at the opposite end of the extension G², will strike another arm corresponding to the arm G¹, and force down the arm, thereby drawing in the slide G⁵, and bring the clutch into connection with the inner pulley, and reverse the movement of the carriage B. Thus the carriage B will travel continuously back and forth. The arms which engage with the inclines on the extension are made adjustable on the shaft G, so that the extent of movement of the carriage B may thereby be varied. The carriage B is furnished with a cutter-stock, L, into which one or more cutters are set, so that in traveling from one end to the other these cutters will dress the surface of the wood which may be presented thereto. This cutter-stock is made adjustable upon pivots *a*, so that it may be turned to any angle of inclination, the axis of these pivots being parallel with the path of movement of the carriage B. Parallel with the ways upon which the carriage B moves a bed, L', is arranged, upon which the wood to be dressed by the cutters is placed. This bed is made adjustable to different inclinations by being hung to the frame at the inner edge, as at *d*, Fig. 2, so that the outer edge may be raised or lowered, as denoted by the broken lines in Fig. 2. The table L' has also a transverse movement imparted to it, as denoted by the broken lines in Fig. 2, to draw it from or force it to the cutters.

The work is placed upon the table, and is held down thereon by means of clamps N. These clamps are hinged to the frame above, as at *n*, and hang over the table, as seen in Fig. 4, and held down by a latch, N¹. The clamps are provided with slides N², which have a vertical movement imparted to them, as occasion may require, through a shaft, N³, on which is a pinion working into each of the vertical slides N². The shaft N³ is turned by means of a pedal, N⁴, through which a lever, N⁵, is turned, and this lever connected by a rod, N⁶, to an arm, N⁷, on the shaft N³, as seen in Fig. 5. To the lever N⁵ a spring, N⁸, is attached, which forces the lever N⁵ up, and causes the pinions on the shaft N³ to correspondingly force down the slides N² upon the work. By pressing down the pedal N⁴, as denoted in Fig. 5, the shaft N³ is turned, and causes the slides N² to rise, as seen in broken lines, Fig. 4. These clamps allow the table to move to and from the cutter, but yet bear sufficiently upon the work to hold it down upon the table. When it is desired to remove or introduce the work the clamps may be turned up, as seen in broken lines, Fig. 2. These clamps may be moved to and from the cutters, if occasion requires, by means of a shaft, P, on which are pinions working in the racks upon the clamp-supports, as seen in Fig. 4. By turning this shaft, which is done through the hand-wheel P¹, the clamps, with the shaft N³, are moved to or from the cutters, and the clamps are arranged upon a guide, P², on which they may be adjusted longitudinally to a greater or less distance apart. R R are stops against which the work is pressed to govern its relative position to the cutters. These are arranged upon slides E' (see Fig. 4) upon the rear side, which slides have a longitudinal movement for the purpose of adjustment; the stops must therefore extend in front of the cutters. These are only necessary when placing the work upon the table, and are adjusted so that when the work is set against the stops and there held the further use of the stops, until the work is dressed, is unnecessary; and as they must pass out of the way of the advancing cutter, they have a transverse movement imparted to them by pinions R¹ on a shaft, R², which work in a rack on the stop-supports R³, so that by the turning of this shaft R² the stops are drawn back, as denoted in broken lines, Fig. 4, or forced forward to the position for setting the work. In order that the stops may automatically withdraw after the work is set, that the cutters may advance and again present themselves after the cutter returns, the shaft R² is made to operate automatically by means of a groove, *r*, in the extension of the slide B. In this groove an arm, R⁴, extends from a shaft, R⁵, and this shaft R⁵ is connected by a segment-gear to the shaft R², as denoted in Fig. 4. At the point of the cutter's starting the arm R⁴ is at the upper or higher end of the groove *r*, as seen in Fig. 7, and as the cutter-carriage advances it forces

the arm R⁴ down the groove *r*, turning the shaft R⁵, and communicating that motion to the stops R, and forcing them back out of the path of the cutter. When the cutter-carriage returns the groove *r* passes on to the arm R⁴, turning it up, and consequently throwing the stops forward again to serve as a guide for setting the work, as before.

In the use of these moving cutters the shavings are necessarily as long as the work dressed, and are liable, from their length, to entangle with the mechanism of the machine. In order to prevent this we arrange a stationary cutter, T, at a convenient point, and on the shaft R² a corresponding cutter, T'; these two cutters forming a pair of shear-blades. As the shaft R² turns in one direction it raises the cutter T', as denoted in broken lines, Fig. 6, and, returning, brings the cutter back. These cutters lie near the moving cutter-carriage B, so that the shaving must necessarily pass between the open cutters, and which, in closing, will cut the shaving.

The form of the cutters and stock in the cutter-carriage must be according to the shape to be wrought. As a jointer, to simply straighten the edge of the boards, the edge of the cutters and stock will of course be straight, but the edge may be beveled by inclining either the cutter-stock or the work-table, as before described.

We claim as our invention—

1. A reciprocating carriage, B, carrying the cutter-stock L, made adjustable in said carriage, in the manner substantially as set forth, combined with the work-table L', substantially as described.

2. In combination with the reciprocating carriage B, cutter-stock L, and work-table L', the inclines G³ G⁶, the clutch D³, and pulleys D D², substantially as and for the purpose specified.

3. In combination with the reciprocating carriage B, cutter-stock L, and work-table L'; the clamp N, made adjustable vertically and transversely, substantially as specified.

4. In combination with the reciprocating carriage B, cutter-stock L, and work-table L', the stops R, the inclined groove *r*, and the connections between said grooves and stops, substantially as and for the purpose of automatically operating said stops.

5. In combination with the reciprocating carriage B, cutter-stock L, and work-table L', the shear-cutters T T', substantially as and for the purpose specified.

LEWIS M. HILLS,
EDWIN ALLEN.

Witnesses to HILLS:

GEORGE OGILVY NOFFATT,
Of the city of Montreal, Gentleman.

O'HARA BAYNES,
Of the city of Montreal, Notarial Clerk.

Witnesses to ALLEN:

D. M. LESTER,
F. R. WARLEY.