

J. A. NEWELL.  
Mechanical-Movement.

No. 162,681.

Patented April 27, 1875.

*Fig. 1.*

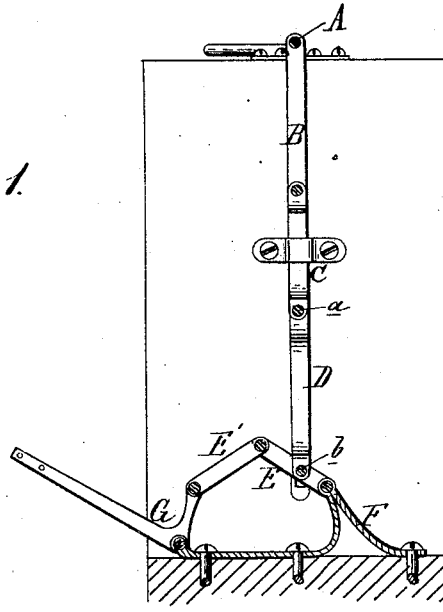

*Fig. 2.*

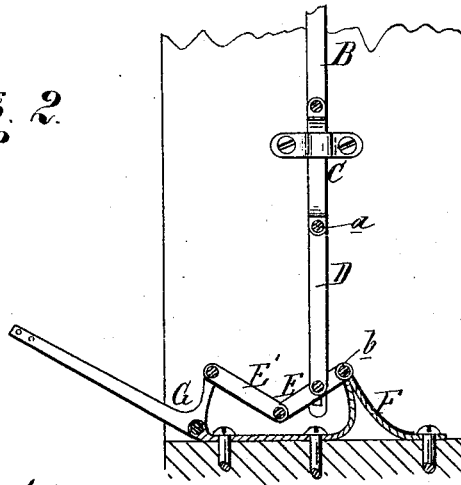

Attest:  
*Edward Barthel*  
*James H. Brien*

Inventor:  
*J. A. Newell*  
By Atty  
*Thos. S. Sprague*

# UNITED STATES PATENT OFFICE.

JOHN A. NEWELL, OF KALAMAZOO, MICHIGAN.

## IMPROVEMENT IN MECHANICAL MOVEMENTS.

Specification forming part of Letters Patent No. **162,681**, dated April 27, 1875; application filed November 7, 1874.

*To all whom it may concern:*

Be it known that I, JOHN A. NEWELL, of Kalamazoo, in the county of Kalamazoo and State of Michigan, have invented a new Mechanical Movement, of which the following is a specification:

The nature of my invention relates to a new and useful mechanical movement for converting rotary into reciprocatory motion, and has for its object to produce two vibrations of a bell-crank lever from one revolution of the cranked driving-shaft, the movement being especially adapted to be used in connection with windmills and other slow-moving motors, for producing a more rapid movement, as in churning.

Figure 1 is an elevation of the movement, showing the connecting-rod at the highest point in its stroke. Fig. 2 is a similar view, showing the position of the parts at the completion of the downstroke of the connecting-rod, the lower end of which is broken away to show the guide.

In the drawing, A represents a cranked driving-shaft, which may be rotated by a windmill or other motor. B is a pitman connecting the crank with the upper end of a plunger, C, which is thereby reciprocated in and through suitable guides on the face of the standard or

frame-work of the apparatus. D is a connecting-rod whose upper end is pivoted at *a* to the plunger C, while its lower end is pivoted at *b* to one of a pair of toggle-levers, E E', the inner ends of which are pivoted together, while the outer end of the lever E is pivoted to a curved bed-plate, F, and the outer end of the lever E' to the vertical shorter arm of a bell-crank, G, pivoted at its angle to said bed-plate. The longer arm of the bell-crank G has the churn-dash or other object to be reciprocated attached to it, and is depressed whenever the toggle levers are extended, or on the same plane, which is passed twice in each reciprocation of the plunger; consequently the bell-crank will be vibrated twice in each revolution of the driving-shaft.

What I claim as my invention, and desire to secure by Letters Patent, is—

The herein-described mechanical movement, consisting of the pitman B, plunger C, connecting-rod D, toggle-levers E E', bed-plate F, and bell-crank G, in combination with a cranked driving-shaft, substantially as described.

JOHN A. NEWELL.

Witnesses:

HENRY J. BROWNELL,  
EDWIN M. IRISH.