

W. B. STOTT.
Rotary-Engine.

No. 162,711.

Patented April 27, 1875.

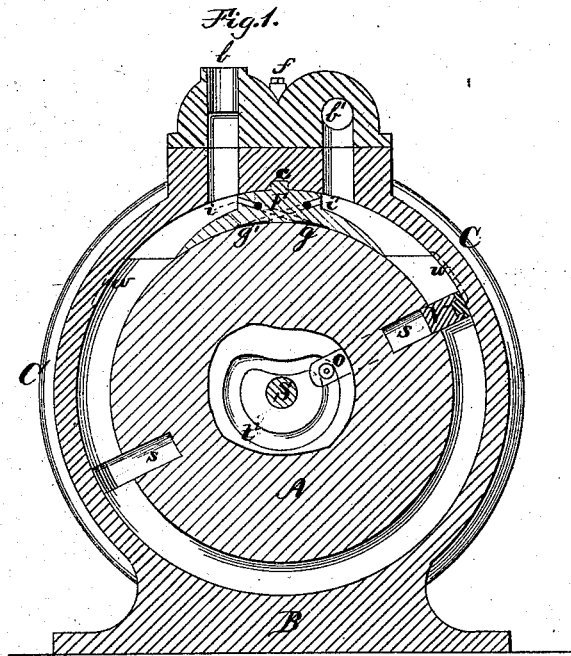

Fig. 6.

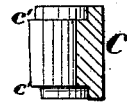

Fig. 3.

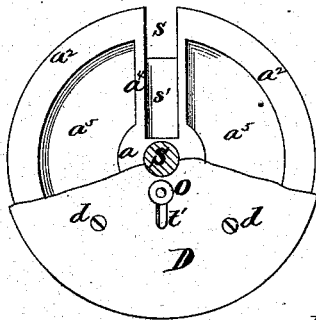

Fig. 2.

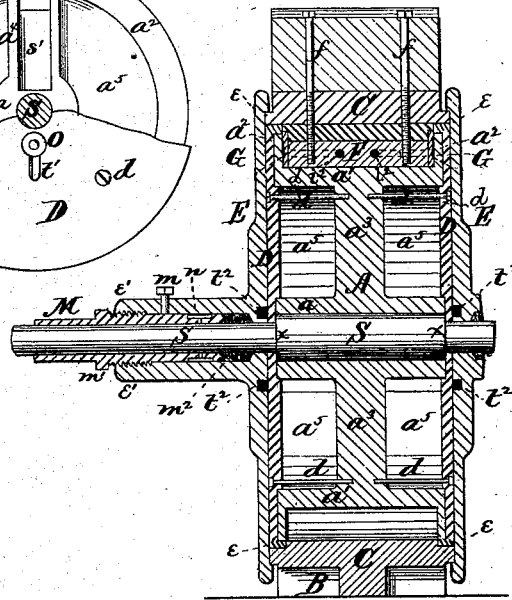

Fig. 4.

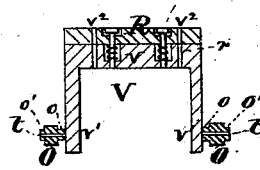
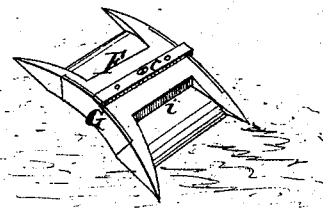

Fig. 5.



WITNESSES

M. Church
E. S. Warner.

INVENTOR

W. B. Stott
By W. H. & C. S. Smith,
His ATTORNEYS

UNITED STATES PATENT OFFICE.

WILLIAM B. STOTT, OF SCRANTON, PENNSYLVANIA.

IMPROVEMENT IN ROTARY ENGINES.

Specification forming part of Letters Patent No. 162,711, dated April 27, 1875; application filed February 17, 1875.

To all whom it may concern:

Be it known that I, WILLIAM B. STOTT, of Scranton, in the county of Luzerne and State of Pennsylvania, have invented certain new and useful Improvements in Rotary Engine; and I do hereby declare the following to be a full, clear, and exact description of the same, reference being had to the accompanying drawings, forming part of this specification, in which—

Figure 1 is a transverse vertical section; Fig. 2, a longitudinal vertical section; Fig. 3, an end elevation of certain parts; Fig. 4, a longitudinal section of the sliding valves; Fig. 5, a perspective view of the abutment, and Fig. 6 a transverse section of one side of the cylinder.

Similar letters of reference in the drawings indicate the same parts.

This invention relates to that class of rotary steam-engines, water-engines, pneumatic engines, pumps, meters, &c., in which a rotary center is combined with a fixed outer case, with radially-sliding valves, and with operating-cams and the usual abutment and ports; and it consists of the several combinations of parts hereinafter more fully described.

In the drawings, S represents the shaft, which is enlarged from x to x , as shown in Fig. 2; and A represents the rotary center, constructed with a hub, a , fixed to the shaft, and a periphery, a^1 , laterally flanged on each side, as shown at a^2 , connected to the hub by a web, a^3 . At each end of the part A a diametrical flange, a^4 , is provided, the outer surfaces of the flange, the hub, and the peripheral flanges being in the same plane. Two open slots, s s , are cut across the periphery of the part A, and connect with deep grooves s' cut in the outer edge of the flanges a^4 , and extending to the enlarged portion of the shaft. The part A thus exhibits a cylinder having terminal recesses a^5 a^5 , a deep peripheral groove, two slots, ss , transversely intersecting the groove, and radial grooves $s' s'$, extending from each end of the open slots s to the central opening provided for the working shaft. DD are two circular plates, fitted tightly to the ends of the center A, and bolted thereto, as represented at dd , so as to revolve therewith. Shoulders upon the plates D project into the recesses a^5 , so as

to center the plates firmly upon the hub. Flanges ee are applied upon the inner edges of the plates DD, and cover the flanges a^2 . C is a stout hollow cylinder resting upon a suitable bed-plate, B, and provided with an induction-port, b , and an exhaust, b' , the latter having two or more openings for the freer discharge of liquids, gases, air, steam, or other substance used in connection with the engine. The center A, end plates DD, and flanges ee are connected together and fitted accurately within the cylinder C, as shown in Fig. 2, and are covered by the end plates E of the engine, which are bolted firmly to the cylinder, in the usual manner. The whole interior apparatus, A, DD, ee , is therefore free to revolve with the shaft S in the space inclosed by the cylinder C and the end plates EE. The inner or concave surface of the cylinder is cut away or rabbeted around its edges, as shown in Fig. 6, so as to leave the middle portion projecting inward farther than the edges, thus forming vertical shoulders c' entirely around the cylinder. The flanges a^2 loosely fit the contracted portion of the cylinder between the two shoulders above described, while the end plates D, or their surrounding flanges ee , loosely fit into the rabbet and bear against the vertical shoulders c' , making a steam-tight joint therewith. Steam will necessarily work out and fill the space between the plates D E, and will thereby balance the plates D.

If the greater pressure of the steam on the induction side of the revolving center causes the latter to work slightly out of true, the edges of the flanges a^2 will not thereby be caused to wear against the concave face of the cylinder to any appreciable extent, so as to bind or produce undue friction. Neither will the edges of the plates D or flanges e wear against the rabbeted portion of the cylinder, nor will the steam-joint be rendered less tight; but the parts will accommodate themselves to the slight change of position, the lateral bearing of the plates D or flanges e against the shoulders will preserve the joints, and the engine will continue to work without any appreciable loss of speed or power, and without heating, jarring, or binding. The flanges e may be made and applied independently of the plates D, or both may be made a part of

the plates D; or one may be made a part of the flange a^2 on one end of the rotary center. In putting the engine together it will be found most convenient to attach one end plate D and flange E to the center, then introduce the center into the cylinder, and then apply the other end plate and flange, although any other mode may be adopted, if preferred. F is the abutment, arranged between the ports $b b'$, and held securely in place by bolts $f f$, and by a stout flange or rib, e , on the abutment, which fits into a corresponding recess in the concave face of the cylinder. The bolts clamp the abutment to the concave, and the flange and recess protect the bolts from lateral strain. In order to partially balance the steam-pressure on the abutment and on the rotary center as much as possible, the concave face of the abutment is provided with two large independent cavities, (shown in black lines at $g g'$ in Fig. 1,) and the cavity g is connected with the live-steam side by a passage, i , while the cavity g' is connected with the exhaust side by a passage, i' . The pressure of the steam in the cavity g tends to balance both the abutment and also the rotating center. The sides of the abutment are fitted with packing-plates G, which may be provided with cavities in their outer surface to balance the steam-pressure upon them, the steam being admitted from one side to the other by suitable perforations through the plates. It is not intended that steam shall get to these plates; but, practically, it cannot be avoided, and this provision is merely to balance the pressure of such steam as works its way to them, and thereby prevent it from giving them too much friction against the side flanges a^2 of the rotating center. In order to hold the plates G properly against the flanges a^2 at all times, so as to insure a tight joint, little sliding pins (shown in Fig. 2 in dotted lines crossing the lower ends of the bolts $f f$) are arranged to abut against the inner face of the plates G, and steam is admitted against the inner end of the pins by passages i^2 , (shown in the same figure,) or by offsets from the live-steam passage i . The steam presses the pins outward against the plates, and holds the latter against the flanges a^2 with all the force necessary for the purpose. Steam might be admitted through the pin-holes directly to the plates G; but in that case the outward pressure upon said plates would be greater than is necessary, and would produce undue friction, thereby tending to retard the engine, waste power, and wear out the working parts. The sliding valves V are constructed substantially in the U form represented in Fig. 4, the top of the valve v , as there shown, sliding in the transverse slot s of the rotary center, and the sides $v^1 v^1$ sliding in the radial groove s' . Stud $t t$, provided with friction sleeves or rolls O, extend outward from the lower ends of the valve through elongated radial slots t^1 in the circular plates D, and project into a cam-groove, t^2 . (Shown clearly in Fig. 1, and in black to repre-

sent their cross-section in Fig. 2.) The cam is of the proper form to draw back the valves as they approach the abutment and thrust them out again as soon as it is passed. The friction-rolls are provided with hubs, (shown at o , Fig. 4,) which work in the slots of the plates D, to insure greater strength, and also to prevent friction. Inasmuch as more or less steam will always work through the valve-joints and get into the cam-grooves, thereby producing pressure upon the friction-wheels, I provide said wheels with a small outside hub, o' , around which is a space for the steam to enter to balance the pressure on the wheels, and prevent friction of their ends against the vertical walls of the cam-groove. To balance the valves steam or other motive fluid is admitted through them by holes $v^2 v^2$. The joint between the outer edge of the valves and the concave surface of the cylinder is kept tight by means of an elastic packing-plate, R, pressed outward by springs r , of any suitable material, and confined to the body of the valves by countersunk bolts r' , which allow the packing-plates a limited movement.

The packing-plates are tongued and grooved into the outer edge of the valves, as shown in Fig. 1, so as to make a tight joint therewith, which will be kept tight by the lateral pressure of the steam when the engine is in operation. The packing-plates are made to cover the entire outer edge of the valves, in order to insure better joints, less wear, and more uniform action. This construction of the valves guides and steadies them in their movements, and enables the power to be uniformly applied at each end of the rotary center; but its greatest advantage arises from bringing the cam-grooves close to the shaft, and thereby materially diminishing the distance to be traveled by them during the revolution of the center.

My improved shaft-bearing is constructed as follows: The end plates of the engine are provided with elongated hubs e' , having a large central chamber extending from their outer end nearly to their inner end, as shown in Fig. 2. Into this chamber is screwed a metal bushing, M, which is kept from revolving with the shaft by means of a set-screw, m . A polygonal shoulder, m^1 , of the bushing enables it to be turned in either direction by means of a suitable wrench. The shaft-packing m^2 is placed at the inner end of the bushing, and is adjusted and compacted at will by screwing up the bushing, while the whole apparatus can be lubricated by means of a chamber, n , and suitable channels connected with an oil-cup. The main object of the bushing is to enable me to correct any eccentricity of the shaft caused by the unequal pressure of the steam on the induction and exhaust sides of the rotary center, and thus at all times keep the shaft and the part A perfectly concentric with the cylinder in which they operate. This is readily effected by simply turning the bushing around whenever

the part A begins to get out of true with the cylinder. Should the parts wear to any great extent, the bushing can be easily taken out and a new one substituted without inconvenience or delay. The end of the bushing may project to a considerable distance beyond the end of the hub, to increase the bearing and supporting surface for the shaft without increasing the distance which the bushing must be screwed out to get at the packing.

In running the engine as a water-engine, pump, &c., the water working in beneath the valves V would prevent them from being drawn in by the cams, and would destroy the engine. To obviate this difficulty in such case, recesses *w* may be cut or provided in the concave face of the cylinder at the points where the valves begin to move in toward the shaft. The water beneath the valves can then escape through the channels *v² v²*, and said recesses into the water-chamber of the engine. The same device may be employed with good results when the apparatus is employed as a steam or air engine.

I claim as my invention—

1. The combination of the fixed cylinder, having a rabbeted concave surface, with the

rotary center A, plates D D, and flanges *e*, substantially as and for the purpose described.

2. The rotary center-block A, having the side flanges *a² a²*, the hub *a*, the recesses *a⁵ a⁵*, the transverse slot *s*, and the lateral radial extensions *s'* of said slot, all arranged substantially as and for the purposes set forth.

3. The valve V, adapted to fit into the open slot *s*, with its arms *v¹ v¹* projecting into and working in the two lateral slots *s'* of the rotary center, substantially as described.

4. The wheels O, having the hubs *o o'* combined with the valve V and the cam-groove *t²*, substantially as and for the purposes set forth.

5. The abutment F, provided with the chambers or recesses *g g'* and the steam-channels *i i'*, substantially as and for the purposes described.

In witness that the above is my invention, I have hereunto set my hand this 12th day of February, 1875.

WM. B. STOTT.

Attest:

CHAS. P. WEBSTER,
M. CHURCH.